



# *Effect of Symmetry on the Orientation Distribution*

27-750

Texture, Microstructure & Anisotropy

A.D. Rollett

*Last revised: 13<sup>th</sup> April '14*

# Objectives

- How to convert Euler angles to an orientation matrix, and back.
- Review of symmetry for both crystals and materials processing.
- Explain *symmetry operators*, their matrix representation, and how to use them to find all the symmetrically equivalent descriptions of a given texture component.
- To illustrate the effect of crystal and sample symmetry on the Euler space required for unique representation of orientations.
- To point out that sample symmetry is statistical rather than physical. Also that orientations related by sample symmetry are, in general, physically distinct.
- To explain why Euler space is generally represented with each angle in the range 0-90°, instead of the most general case of 0-360° for  $\phi_1$  and  $\phi_2$ , and 0-180° for  $\Phi$ .
- To point out the special circumstance of cubic crystal symmetry, combined with orthorhombic sample symmetry, and the presence of 3 equivalent points in the 90x90x90° “box” or “reduced space”.
- To explain the concept of “fundamental zone”.
- Part 1 of the lecture provides a qualitative description of symmetry and its effects. Part 2 provides the quantitative description of how to express symmetry operations as rotation matrices and apply them to orientations.

## *In Class Questions: 1*

1. What is a fundamental zone?
2. What is the difference between “crystal symmetry” and “sample symmetry”?
3. Which kind of symmetry is physical in nature, and which one is statistical?
4. Which point group is applicable to cubic metals? Hexagonal metals? Tetragonal tin?
5. List the common types of sample symmetry.

## *In Class Questions: 2*

1. What limits on the Euler angles are appropriate to cubic-monoclinic symmetry?
2. Give an example of a symmetry operator in the hexagonal group 622.
3. Explain how to start with a set of Euler angles, apply symmetry and obtain a new set of Euler angles for the symmetrically equivalent orientation.
4. If we apply the symmetry of a given point group, by what factor is the volume of the resulting sub-space decreased, compared to the original orientation volume?
5. Based on a matrix representation of orientations, do we left-multiply or right-multiply to apply a sample symmetry operator?



## *In Class Questions: 3*

1. How can we test our scheme to calculate symmetry-related orientations to make sure that we apply crystal and sample symmetry correctly?
2. If we change the sample symmetry to monoclinic, how large a space should we use in Euler angle space?
3. If we change the crystal symmetry to hexagonal, how does this change the range of Euler angles required? Can you explain why the 3<sup>rd</sup> Euler angle only needs to have the range 0-60°?
4. Draw a stereographic projection and add ovals to represent diads, triangles to represent triads and squares to represent tetrads until you have a diagram of the O(432) point group.

# Geometry of $\{hkl\}\langle uvw\rangle$

## Sample to Crystal (primed)

Miller index notation of texture component specifies direction cosines of crystal directions // to sample axes. Form the second axis from the cross-product of the 3<sup>rd</sup> and 1<sup>st</sup> axes.

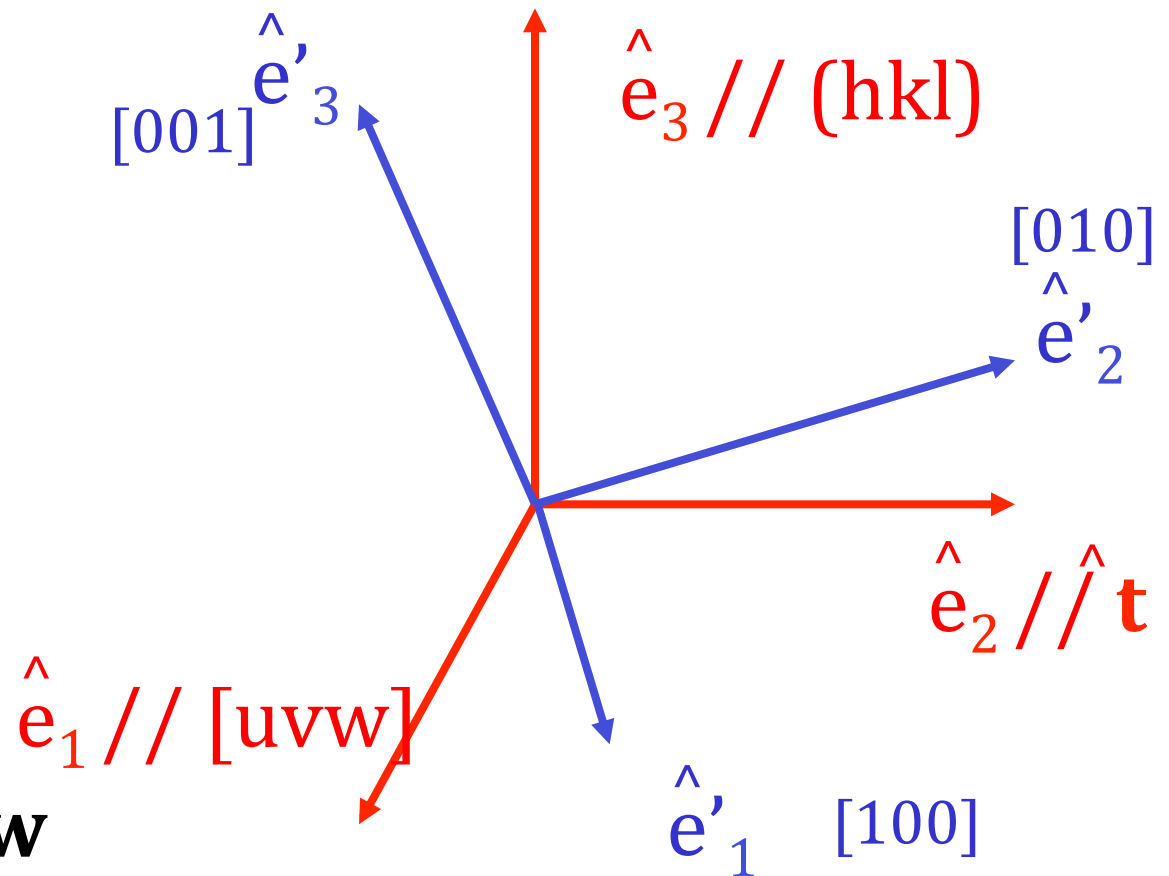

$$\mathbf{t} = \mathbf{hkl} \times \mathbf{uvw}$$

Obj/notation **AxisTransformation** Matrix EulerAngles Components

# Form matrix from Miller Indices

Basic idea: we can construct the complete rotation matrix from two known, easy to determine columns of the matrix. Knowing that we have columns rather than rows is a consequence of the sense of rotation, which is equivalent to the direction in which the axis transformation is carried out.

$$\hat{\mathbf{n}} = \frac{(h, k, l)}{\sqrt{h^2 + k^2 + l^2}}$$

$$\hat{\mathbf{b}} = \frac{(u, v, w)}{\sqrt{u^2 + v^2 + w^2}}$$

*Sample*

$$\hat{\mathbf{t}} = \frac{\hat{\mathbf{n}} \times \hat{\mathbf{b}}}{|\hat{\mathbf{n}} \times \hat{\mathbf{b}}|}$$

$$a_{ij} = \text{Crystal} \begin{pmatrix} b_1 & t_1 & n_1 \\ b_2 & t_2 & n_2 \\ b_3 & t_3 & n_3 \end{pmatrix}$$

Obj/notation AxisTransformation **Matrix** EulerAngles Components

# *Bunge Euler angles to Matrix*

Basic idea: construct the complete orientation matrix from individual, easy to understand rotations that are based on the three different Euler angles. Demonstrate the equivalence between the rotation matrix constructed from these rotations, and the matrix derived from direction cosines. “Rotation” in this context means “transformation of axes”.

**Rotation 1 ( $\phi_1$ ):** rotate axes (anticlockwise) about the (sample) 3 [ND] axis;  $\mathbf{Z}_1$ .

**Rotation 2 ( $\Phi$ ):** rotate axes (anticlockwise) about the (rotated) 1 axis [100] axis;  $\mathbf{X}$ .

**Rotation 3 ( $\phi_2$ ):** rotate axes (anticlockwise) about the (crystal) 3 [001] axis;  $\mathbf{Z}_2$ .

Obj/notation	AxisTransformation	Matrix	EulerAngles	Components
--------------	--------------------	--------	-------------	------------

# *Bunge Euler angles to Matrix, contd.*

$$Z_1 = \begin{pmatrix} \cos \phi_1 & \sin \phi_1 & 0 \\ -\sin \phi_1 & \cos \phi_1 & 0 \\ 0 & 0 & 1 \end{pmatrix},$$

$$Z_2 = \begin{pmatrix} \cos \phi_2 & \sin \phi_2 & 0 \\ -\sin \phi_2 & \cos \phi_2 & 0 \\ 0 & 0 & 1 \end{pmatrix}$$

$$X = \begin{pmatrix} 1 & 0 & 0 \\ 0 & \cos \Phi & \sin \Phi \\ 0 & -\sin \Phi & \cos \Phi \end{pmatrix}$$

Combine the 3 rotations via matrix multiplication; 1<sup>st</sup> on the right, last on the left:

$$\mathbf{A} = \mathbf{Z}_2 \mathbf{X} \mathbf{Z}_1$$

Obj/notation AxisTransformation **Matrix** EulerAngles Components

# Matrix with Bunge Angles

$$\begin{array}{ccc}
 \begin{array}{l} \text{[uvw]} \\ \left( \begin{array}{l} \cos\varphi_1 \cos\varphi_2 \\ -\sin\varphi_1 \sin\varphi_2 \cos\Phi \\ -\cos\varphi_1 \sin\varphi_2 \\ -\sin\varphi_1 \cos\varphi_2 \cos\Phi \\ \sin\varphi_1 \sin\Phi \end{array} \right) \end{array} & \mathbf{A} = \mathbf{Z}_2 \mathbf{X} \mathbf{Z}_1 = & \begin{array}{l} \text{(hkl)} \\ \left( \begin{array}{l} \sin\varphi_2 \sin\Phi \\ \cos\varphi_2 \sin\Phi \\ \cos\Phi \end{array} \right) \end{array} \\
 \begin{array}{l} \sin\varphi_1 \cos\varphi_2 \\ +\cos\varphi_1 \sin\varphi_2 \cos\Phi \\ -\sin\varphi_1 \sin\varphi_2 \\ +\cos\varphi_1 \cos\varphi_2 \cos\Phi \\ -\cos\varphi_1 \sin\Phi \end{array} & & 
 \end{array}$$

Obj/notation AxisTransformation **Matrix** EulerAngles Components

# Matrix, Miller Indices

- The general Rotation Matrix,  $a$ , can be represented as in the following:

$$\begin{array}{l}
 [100]_{\text{xtal}} \text{ direction} \longrightarrow \\
 [010]_{\text{xtal}} \text{ direction} \longrightarrow \\
 [001]_{\text{xtal}} \text{ direction} \longrightarrow
 \end{array}
 \begin{bmatrix}
 a_{11} & a_{12} & a_{13} \\
 a_{21} & a_{22} & a_{23} \\
 a_{31} & a_{32} & a_{33}
 \end{bmatrix}$$

- Here the Rows are the direction cosines for the 3 crystal axes, [100], [010], and [001] expressed in the *sample coordinate system* (pole figure).

Obj/notation AxisTransformation **Matrix** EulerAngles Components

# Matrix, Miller Indices

- The *columns* represent components of three other unit vectors:

$$\begin{array}{ccc}
 [uvw] \equiv \text{RD} & \text{TD} & \text{ND} \equiv (hkl) \\
 \downarrow & \downarrow & \downarrow \\
 \left[ \begin{array}{c} a_{11} \\ a_{21} \\ a_{31} \end{array} \right] & \left[ \begin{array}{c} a_{12} \\ a_{22} \\ a_{32} \end{array} \right] & \left[ \begin{array}{c} a_{13} \\ a_{23} \\ a_{33} \end{array} \right]
 \end{array}$$

- Here the Columns are the direction cosines (i.e.  $hkl$  or  $uvw$ ) for the sample axes, RD, TD and Normal directions expressed in the *crystal coordinate system*. Compare to inverse pole figures.

Obj/notation AxisTransformation **Matrix** EulerAngles Components



# Compare Matrices

$$\begin{array}{c}
 \text{[uvw]} \quad \text{(hkl)} \quad \text{[uvw]} \quad \text{(hkl)} \\
 \text{Sample} \\
 a_{ij} = \text{Crystal} \begin{pmatrix} b_1 & t_1 & n_1 \\ b_2 & t_2 & n_2 \\ b_3 & t_3 & n_3 \end{pmatrix} \equiv \begin{pmatrix} \cos\varphi_1 \cos\varphi_2 & \sin\varphi_1 \cos\varphi_2 \\ -\sin\varphi_1 \sin\varphi_2 \cos\Phi & +\cos\varphi_1 \sin\varphi_2 \cos\Phi \\ -\cos\varphi_1 \sin\varphi_2 & -\sin\varphi_1 \sin\varphi_2 \\ -\sin\varphi_1 \cos\varphi_2 \cos\Phi & +\cos\varphi_1 \cos\varphi_2 \cos\Phi \\ \sin\varphi_1 \sin\Phi & -\cos\varphi_1 \sin\Phi \end{pmatrix} \begin{pmatrix} \sin\varphi_2 \sin\Phi \\ \cos\varphi_2 \sin\Phi \\ \cos\Phi \end{pmatrix}
 \end{array}$$

Basic idea: the complete orientation matrix that describes an orientation must be numerically the same, coefficient by coefficient, regardless of whether it is constructed from the Euler angles, or from the Miller indices. Therefore we can equate the two matrix descriptions, entry by entry.

Obj/notation AxisTransformation **Matrix** EulerAngles Components

# Miller indices from Euler angle matrix

Compare the matrix formed from the Miller indices with the Euler angle matrix. Extract indices from the 1<sup>st</sup> and 3<sup>rd</sup> columns

$$h = n \sin \Phi \sin \varphi_2$$

$$k = n \sin \Phi \cos \varphi_2$$

$$l = n \cos \Phi$$

$$u = n' (\cos \varphi_1 \cos \varphi_2 - \sin \varphi_1 \sin \varphi_2 \cos \Phi)$$

$$v = n' (-\cos \varphi_1 \sin \varphi_2 - \sin \varphi_1 \cos \varphi_2 \cos \Phi)$$

$$w = n' \sin \Phi \sin \varphi_1$$

$n, n'$  = arbitrary factors to make integers from real numbers

Obj/notation AxisTransformation Matrix EulerAngles Components

## Euler angles from Orientation Matrix

$$\varphi_1 = \tan^{-1}\left(\frac{a_{31}/\sin\Phi}{-a_{32}/\sin\Phi}\right) = ATAN2(a_{31}/\sin\Phi, -a_{32}/\sin\Phi)$$

$$\Phi = \cos^{-1}(a_{33})$$

$$\varphi_2 = \tan^{-1}\left(\frac{a_{13}/\sin\Phi}{a_{23}/\sin\Phi}\right) = ATAN2(a_{13}/\sin\Phi, a_{23}/\sin\Phi)$$

Notes: the range of inverse cosine (ACOS) is  $0-\pi$ , which is sufficient for  $\Phi$ ; from this,  $\sin(\Phi)$  can be obtained. The range of inverse tangent is  $0-2\pi$ , so numerically one must use the  $ATAN2(y,x)$  function) to calculate  $\varphi_1$  and  $\varphi_2$ . **Caution: in Excel, one has  $ATAN2(x,y)$ , which is the reverse order of arguments compared to the usual  $ATAN2(y,x)$  in Fortran, C (use 'double atan2 ( double y, double x ); ' etc.!**

Also, if the second Euler angle is too close to zero, or  $180^\circ$ , then the standard formulae fail because  $\sin(\Phi)$  approaches zero (see next slide). The formulae to the right deal with this special case, where the 1st and 3rd angles are linearly dependent; distributing the rotation between them is arbitrary.

$$\text{if } a_{33} \approx 1, \Phi = 0, \varphi_1 = ATAN2(a_{12}, a_{11}) / 2, \text{ and } \varphi_2 = \varphi_1$$

$$\text{if } a_{33} \approx -1, \Phi = 0, \varphi_1 = ATAN2(a_{12}, a_{11}) / 2, \text{ and } \varphi_2 = -\varphi_1$$

## Special Case: $\Phi = 0$

$$\mathbf{A} = \mathbf{Z}_2 \mathbf{I} \mathbf{Z}_1 =$$

$$\begin{pmatrix} \cos \varphi_1 \cos \varphi_2 & \sin \varphi_1 \cos \varphi_2 & 0 \\ -\sin \varphi_1 \sin \varphi_2 & +\cos \varphi_1 \sin \varphi_2 & 0 \\ -\cos \varphi_1 \sin \varphi_2 & -\sin \varphi_1 \sin \varphi_2 & 0 \\ -\sin \varphi_1 \cos \varphi_2 & +\cos \varphi_1 \cos \varphi_2 & 0 \\ 0 & 0 & 1 \end{pmatrix} = \begin{pmatrix} \cos 2\varphi_1 & \sin 2\varphi_1 & 0 \\ -\sin 2\varphi_1 & -\cos 2\varphi_1 & 0 \\ 0 & 0 & 1 \end{pmatrix}$$

Set  $\phi_1 = \phi_2$

$\mathbf{I}$  is the Identity matrix

Obj/notation AxisTransformation **Matrix** EulerAngles Components

## Special Case: $\Phi = 180^\circ$ , $\cos\Phi = -1$

$$\mathbf{A} = \mathbf{Z}_2 \mathbf{X} \mathbf{Z}_1 =$$

$$\mathbf{X} = \begin{pmatrix} 1 & 0 & 0 \\ 0 & -1 & 0 \\ 0 & 0 & -1 \end{pmatrix}$$

$$\begin{pmatrix} \cos\varphi_1 \cos\varphi_2 & \sin\varphi_1 \cos\varphi_2 & 0 \\ +\sin\varphi_1 \sin\varphi_2 & -\cos\varphi_1 \sin\varphi_2 & 0 \\ -\cos\varphi_1 \sin\varphi_2 & -\sin\varphi_1 \sin\varphi_2 & 0 \\ +\sin\varphi_1 \cos\varphi_2 & -\cos\varphi_1 \cos\varphi_2 & 0 \\ 0 & 0 & 1 \end{pmatrix} = \begin{pmatrix} \cos 2\varphi_1 & \sin 2\varphi_1 & 0 \\ \sin 2\varphi_1 & -\cos 2\varphi_1 & 0 \\ 0 & 0 & 1 \end{pmatrix}$$

Set  $\phi_1 = -\phi_2$

# *Crystal vs. Sample Symmetry*

- An understanding of the role of symmetry is essential in texture.
- Two separate and distinct forms of symmetry are relevant:
  - CRYSTAL symmetry
  - SAMPLE symmetry
- **Crystal symmetry** is always present (even if, in principle, heavily defected crystals may exhibit lower symmetry) and must always be accounted for. **Sample symmetry** is only present on a statistical basis, i.e. only a polycrystal can exhibit sample symmetry for the texture as a whole.
- Typical usage lists the combination crystal-sample symmetry in that order, e.g. *cubic-orthorhombic*.

# Take-Home Message

The essential points of this lecture are:

1. Crystal symmetry means that a crystal can be rotated in various ways that leave it unchanged (physically indistinguishable). In orientation space, the equivalent result is that any given orientation is related to exactly as many other orientations as there are symmetry operators (understandable in terms of group theory).
2. Because there are multiple equivalent points, we usually divide up the full orientation space (e.g.  $360^\circ \times 180^\circ \times 360^\circ$  in Euler space) and use only a small portion of it (e.g.  $90^\circ \times 90^\circ \times 90^\circ$ ).
3. Sample symmetry has the same sort of effect as crystal symmetry, even though it is a statistical symmetry (and orientations related by a sample symmetry element *are* physically distinguishable and *do* have a misorientation between them. Sample symmetry is evident in *pole figures* whereas crystal symmetry is evident in *inverse pole figures*.
4. Unfortunately, Euler space (spherical angles) means that the dividing planes have odd shapes and so for the common *cubic-orthorhombic* combination, we have 3 copies of the *fundamental zone* in the range  $0-90^\circ$  for each angle. Rodrigues space is far simpler in this respect because symmetry operators always lead to flat dividing planes.

# Deformation vs. Sample Symmetry

- Note that the texture of a material is a consequence of its thermomechanical history (and therefore offers clues about that history).
- The (statistical) sample symmetry is directly related to the symmetry of the preceding deformation.
- In general, the sample symmetry reflects the lowest symmetry deformation that was imposed on the material.
- Rolling is a plane strain deformation, with *orthorhombic symmetry*. We call it “plane strain” because (in the ideal case) all the strain occurs in one plane, the RD-ND plane with zero strain in the TD (parallel to the axes of the rolls). Torsion is a simple shear, with *monoclinic symmetry*. Wire drawing is an axi-symmetric deformation with *cylindrical symmetry*. Upsetting or *uniaxial compression* is also an axi-symmetric deformation with *cylindrical symmetry*.

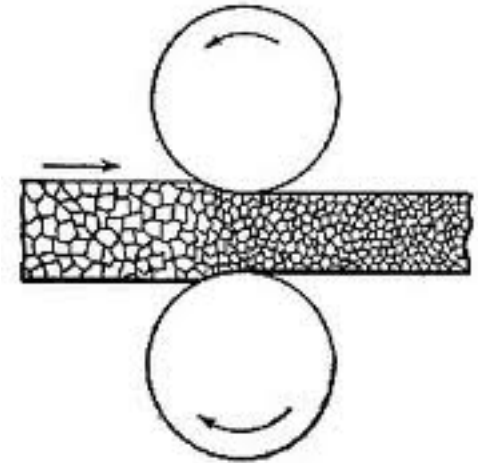

Rolling:  
[anvilfire.com](http://anvilfire.com)

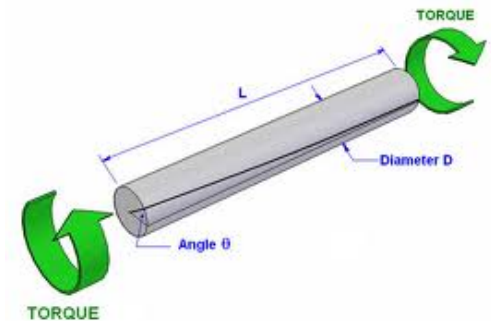

torsion:  
[ejsong.com](http://ejsong.com)



# Pole Figure for Wire Texture

- (111) pole figure showing a maximum intensity at a specific angle from a particular direction in the sample, and showing an infinite rotational symmetry ( $C_\infty$ ).
- F.A.=Fiber Axis (parallel to the length of the wire)
- A particular crystal direction in *all* crystals is aligned with this *fiber axis* (i.e. a particular sample direction).
- For a cubic material, this combination would be classed as *cubic-cylindrical*.

forth-armoury.com

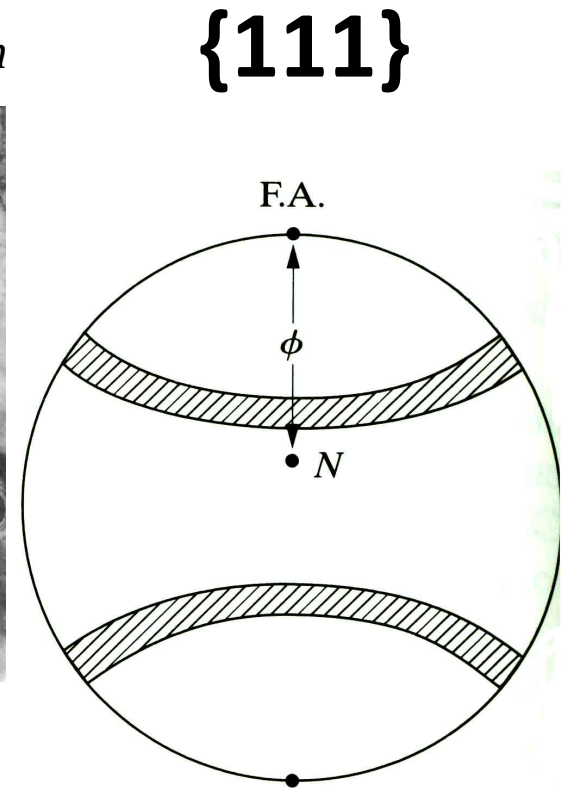

**In this case,  $\langle 100 \rangle // \text{F.A.}$**

# *Effect of Symmetry*

- Illustration of 3-fold, 4-fold, 6-fold rotational symmetry

The essential point about applying a symmetry operation is that, once it has been done, you cannot tell that anything has changed. In other words, the rotated or reflected object is physically indistinguishable from what you started with.

Note the symbols used to denote the different rotational symmetry elements.

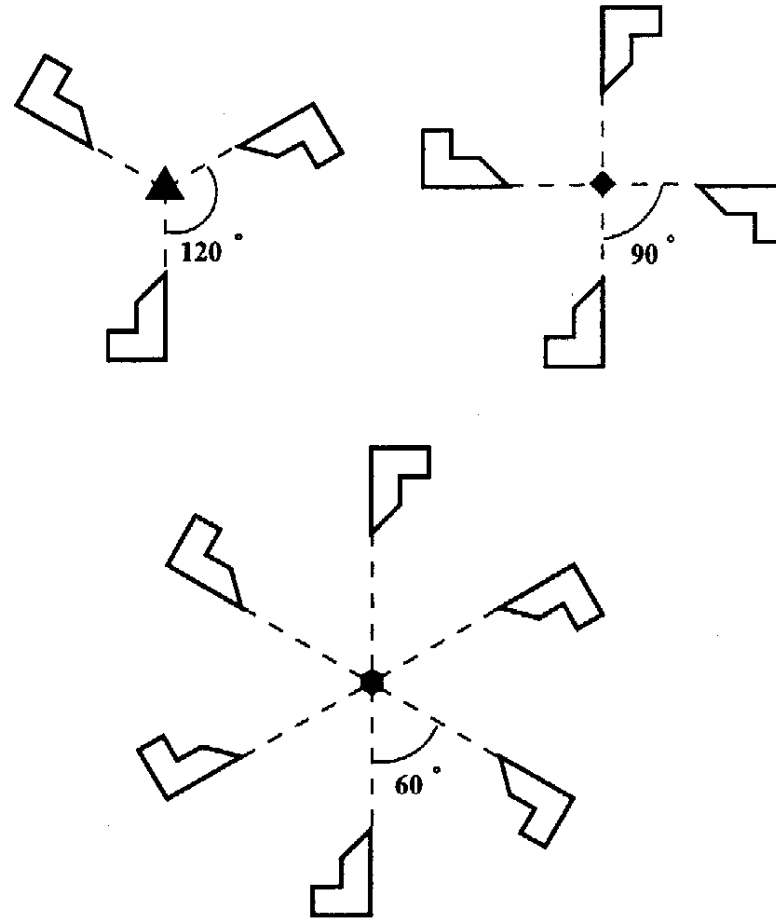
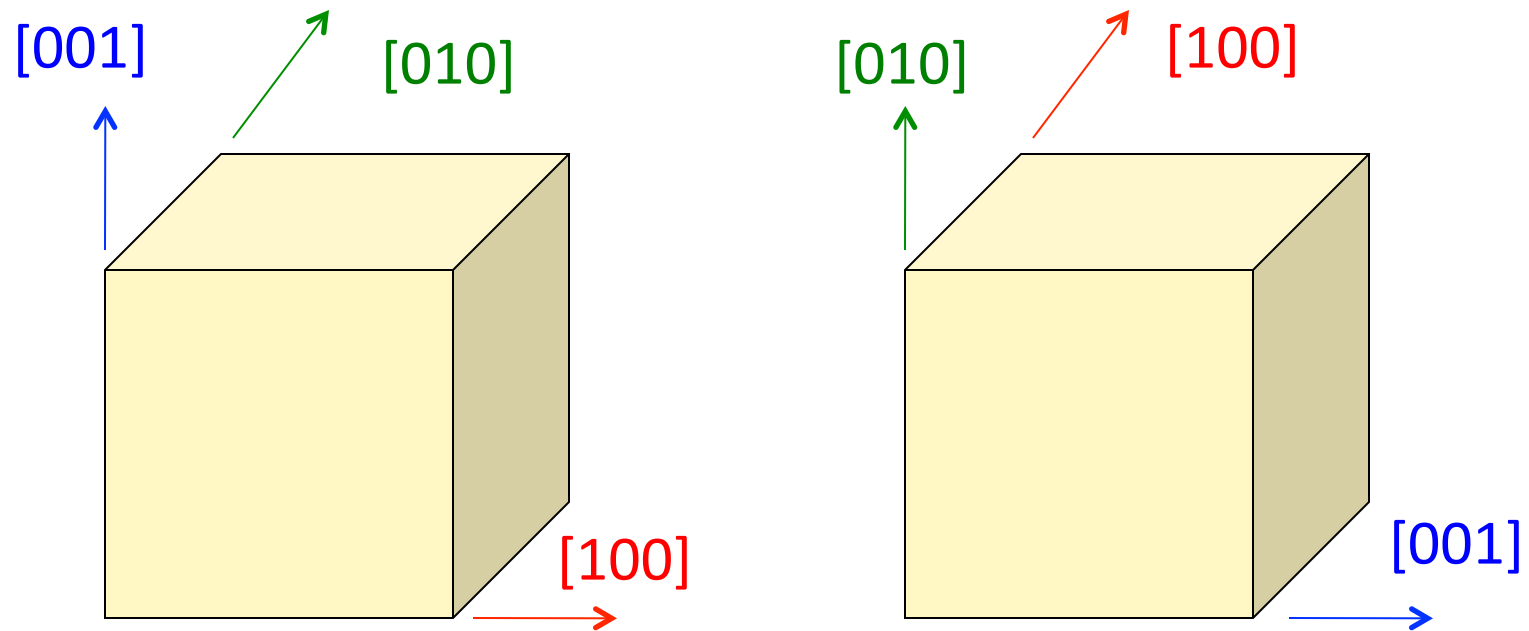

Figure 9.2: a) 3-fold, b) 4-fold, and c) 6-fold rotational symmetry.

# *Effect of Symmetry: Example*



- Note how one can re-label the axes but leave the physical object (crystal) unchanged.
- Which symmetry operator was applied (from  $O(432)$ )?

Stereographic projections of symmetry elements and general poles in the cubic point groups with *Hermann-Mauguin* and *Schoenflies* designations.

Note the presence of *four* triad symmetry elements in all these groups on  $\langle 111 \rangle$ .

Cubic metals mostly fall under  $m\bar{3}m$ .

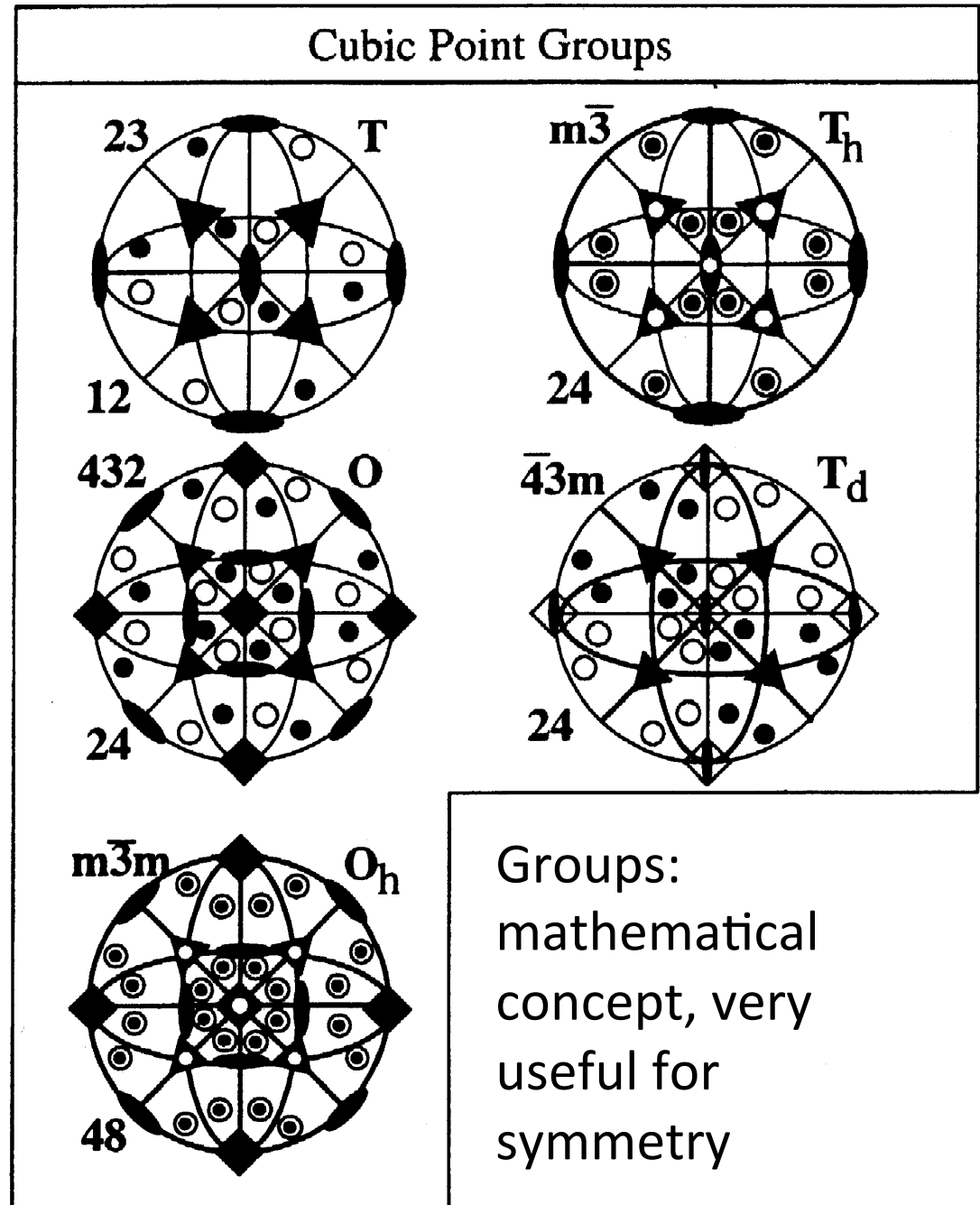

# Sample Symmetry

Torsion, shear:  
Monoclinic, 2.

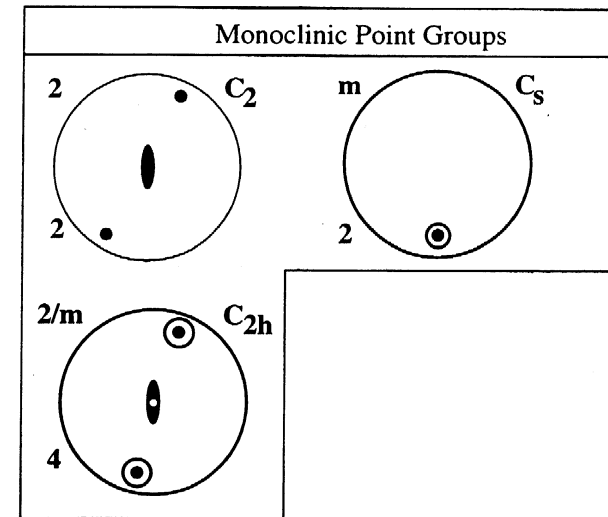
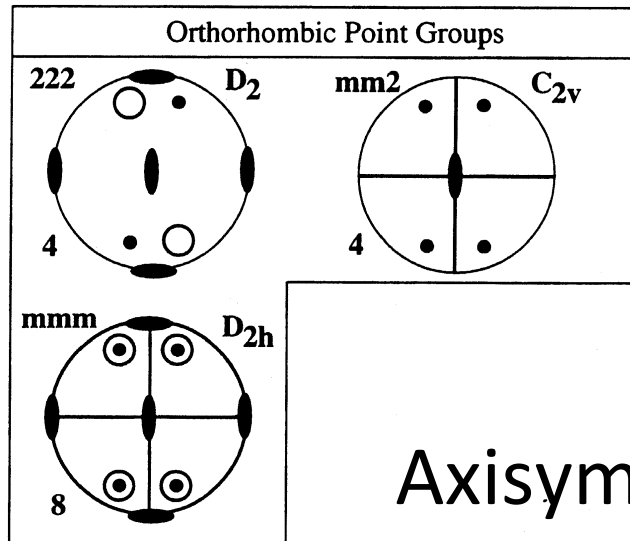

Rolling, plane strain  
compression,  $mmm$ .

Axisymmetric:  $C_\infty$

Otherwise,  
*triclinic*.

# Fundamental Zone

- The **fundamental zone (or asymmetric unit)** is the portion or subset of orientation space within which each orientation (or misorientation, when we later discuss grain boundaries) is described by a single, unique point.
- The fundamental zone is the *minimum* amount of orientation space required to describe all orientations.
- Example: the *standard stereographic triangle (SST)* for directions in cubic crystals.
- The size of the fundamental zone depends on the amount of symmetry present in both crystal and sample space. More symmetry  $\Rightarrow$  smaller fundamental zone.
- Note that in Euler space, the  $90 \times 90 \times 90^\circ$  region typically used for cubic [crystal]+orthorhombic [sample] symmetry is *not* a fundamental zone because it contains 3 copies of the actual zone!

# *Symmetry Issues*

- Crystal symmetry operates in a frame attached to the crystal axes.
- Based on the definition of Euler angles, crystal symmetry elements produce relations between the second & third angles.
- Sample symmetry operates in a frame attached to the sample axes.
- Sample symmetry produces relations between the first & second angles.
- The combination of crystal and sample symmetry is written as *crystal-sample*, e.g. *cubic-orthorhombic*, or *hexagonal-triclinic*.

## *Choice of Section Size*

- Quad, Diad symmetry elements are easy to incorporate, but Triads are highly inconvenient.
- Four-fold rotation elements (and mirrors in the orthorhombic group) are used to limit the third,  $\phi_2$ , (first,  $\phi_1$ ) angle range to 0-90°.
- Second angle,  $\Phi$ , has range 0-90° (diffraction adds a center of symmetry).



# *Section Sizes*

## *Crystal - Sample*

- *Cubic-Orthorhombic:*  
 $0 \leq \phi_1 \leq 90^\circ, 0 \leq \Phi \leq 90^\circ, 0 \leq \phi_2 \leq 90^\circ$
- *Cubic-Monoclinic:*  
 $0 \leq \phi_1 \leq 180^\circ, 0 \leq \Phi \leq 90^\circ, 0 \leq \phi_2 \leq 90^\circ$
- *Cubic-Triclinic:*  
 $0 \leq \phi_1 \leq 360^\circ, 0 \leq \Phi \leq 90^\circ, 0 \leq \phi_2 \leq 90^\circ$
- *But, these limits do not delineate a fundamental zone.*

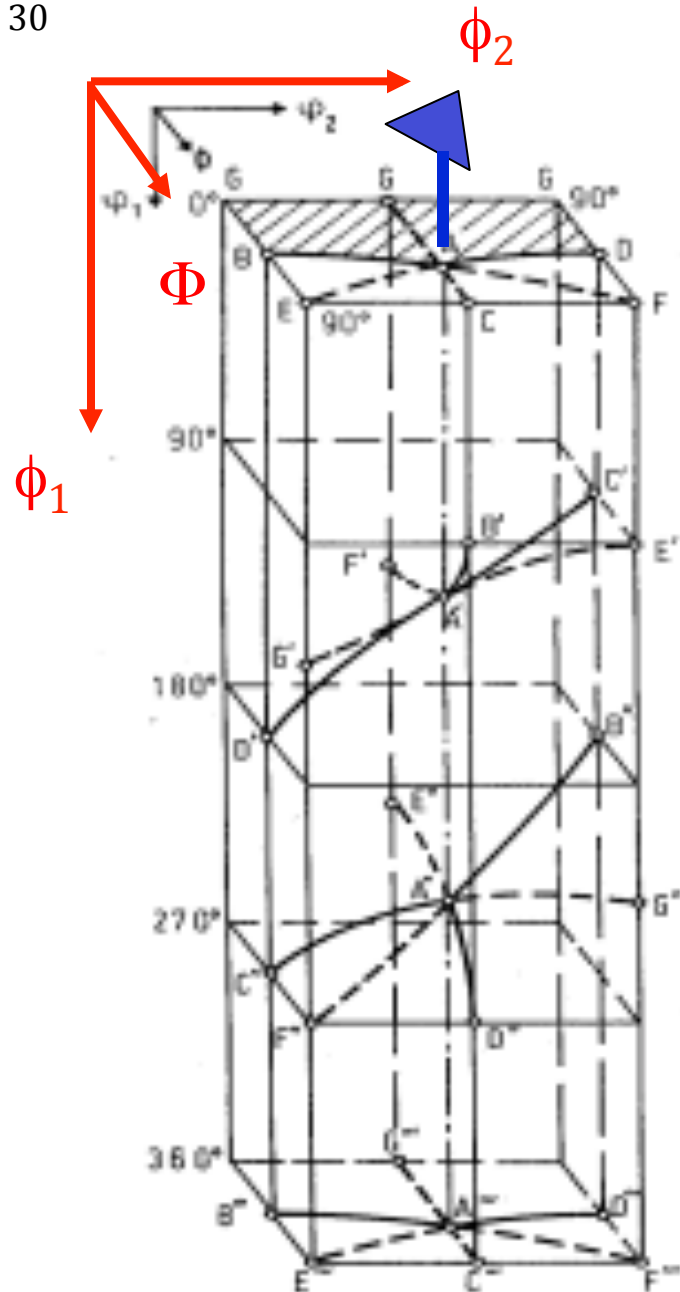

*Points related by triad  
symmetry  
element on  
<111>  
(triclinic  
sample symmetry)*

Take a point, e.g. "B"; operate on it with the 3-fold rotation axis (blue triad); the set of points related by the triad are B, B', B'', with B''' being the same point as B. The point is, that as you operate on a point (orientation) with a symmetry operation, in general *all the Euler angles change*.

## Effect of 3-fold axis

section  
in  $\phi_1$  cuts  
through  
more than  
one subspace

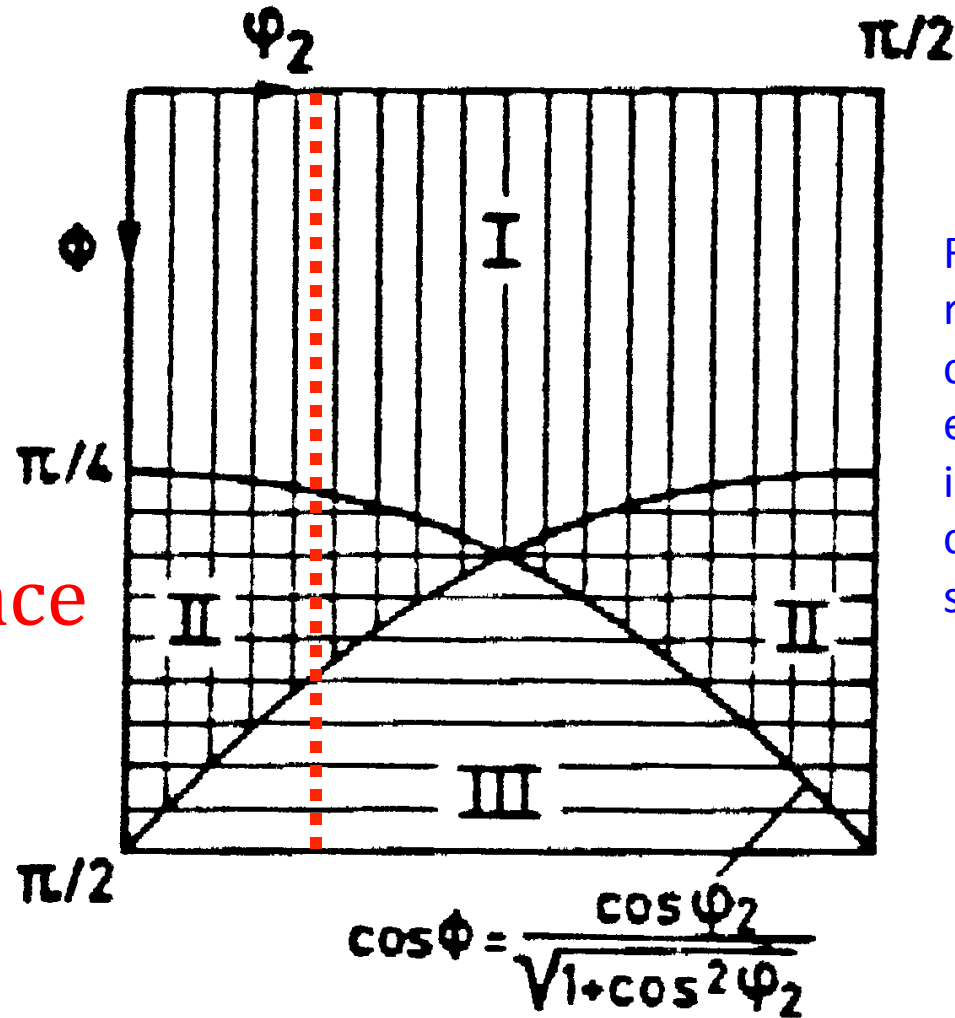

Regions I, II and III are related by the triad crystal symmetry element, i.e.  $120^\circ$  about  $\langle 111 \rangle$ , combined with sample symmetry.

[Bunge]

# Example of 3-fold symmetry

The “S” component,  $\{123\}\langle 634\rangle$  has angles  $\{59, 37, 63\}$  also  $\{27, 58, 18\}, \{53, 74, 34\}$  and occurs in three related locations in Euler space.  $10^\circ$  scatter shown about component.

Regions I, II and III are related by the triad crystal symmetry element, i.e.  $120^\circ$  about  $\langle 111\rangle$ , combined with sample symmetry.

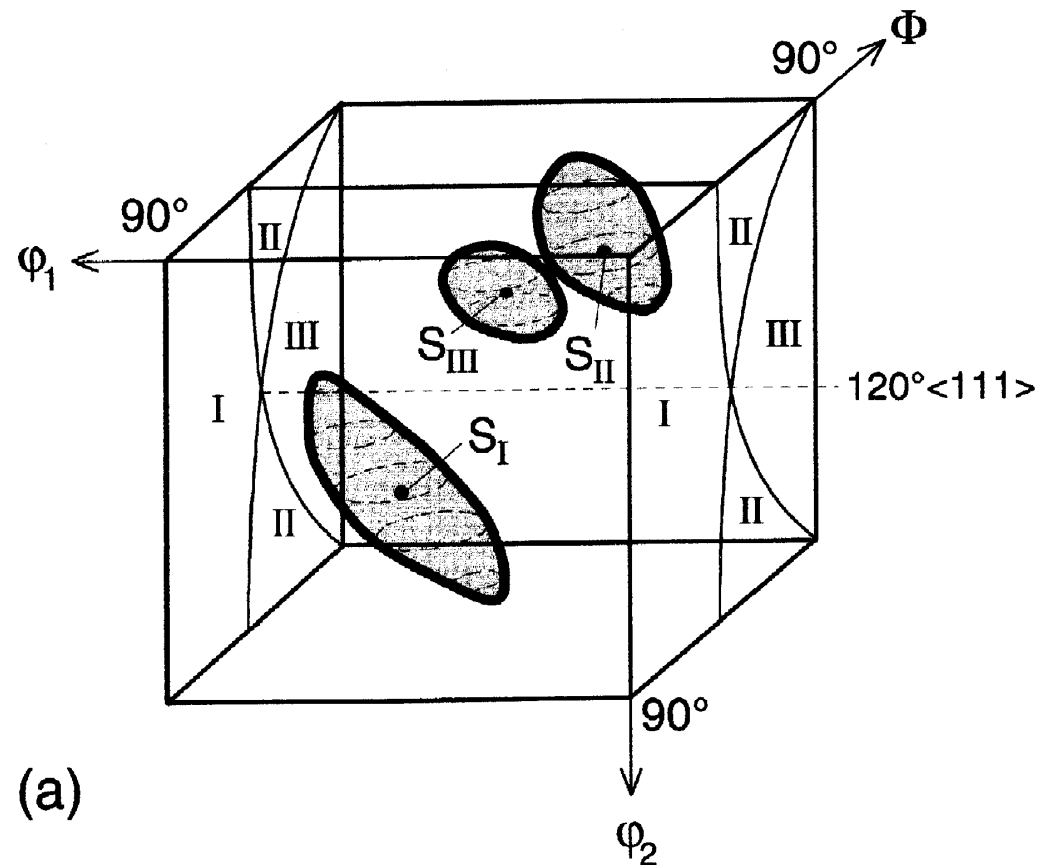

[Randle & Engler, fig. 5.7]

*S*  
component  
in  $\phi_2$   
sections

Regions I, II and III are related by the triad symmetry element, i.e.  $120^\circ$  about  $\langle 111 \rangle$ .  $10^\circ$  scatter shown about the S component.

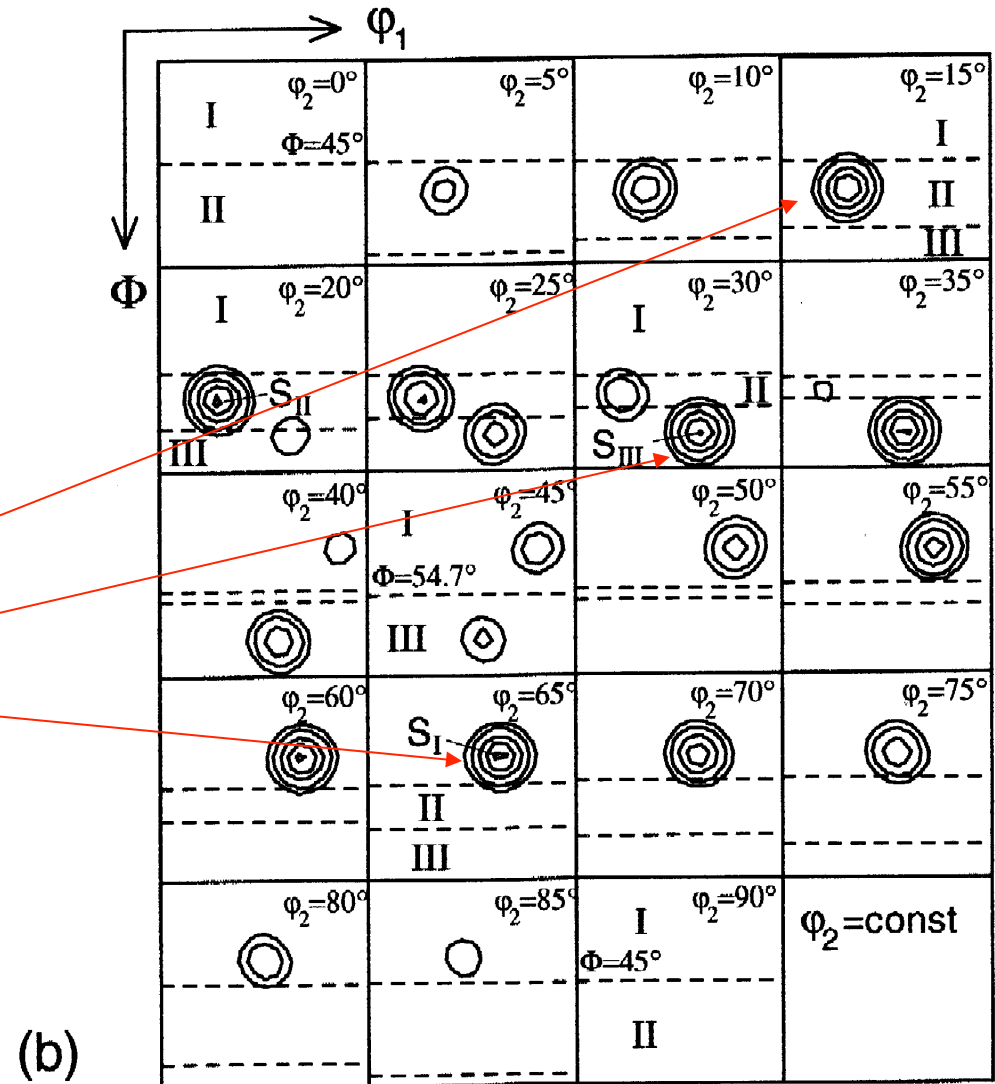

Randle & Engler, fig. 5.7

# Orthorhombic Sample Symmetry (*mmm*) Relationships in Euler Space

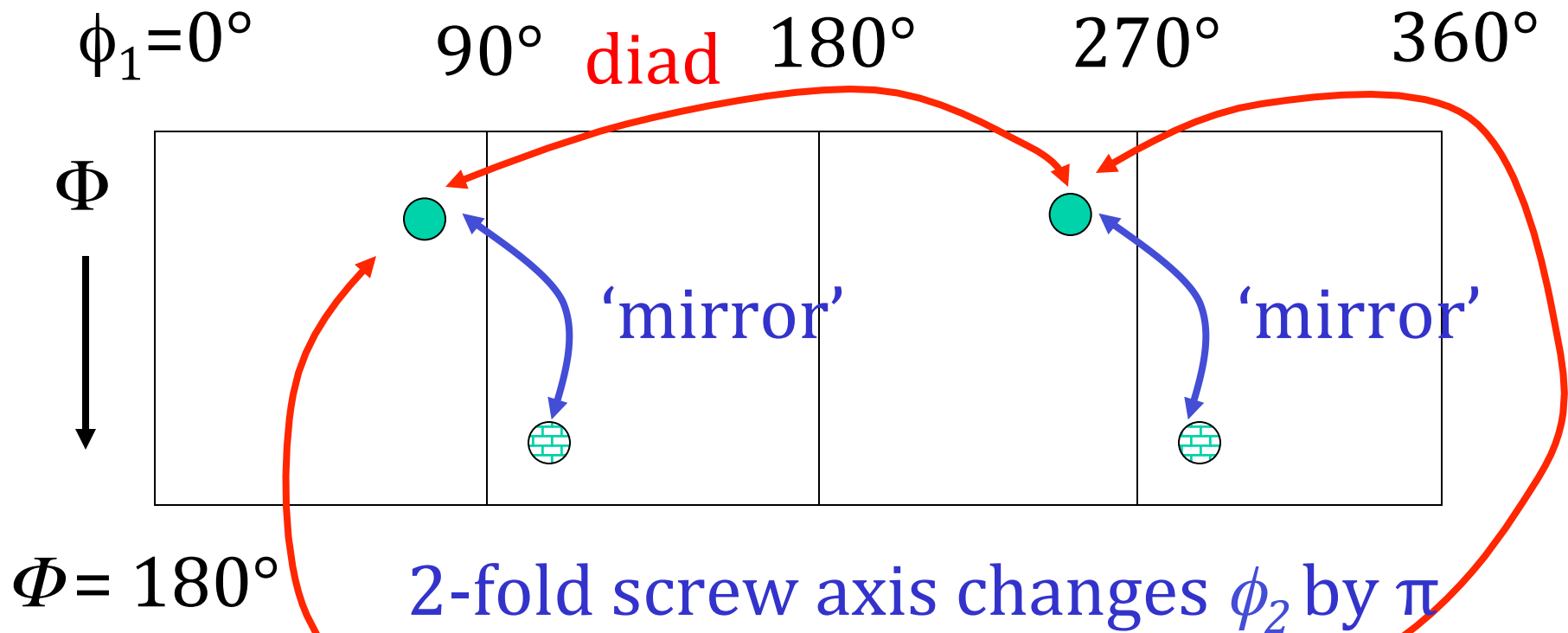

Note: this slide illustrates how the set of 3 diads (+ identity) in sample space operate on a given point. The relationship labeled as 'mirror' is really a diad that acts like a 2-fold screw axis in Euler space.

# Sample symmetry, detail

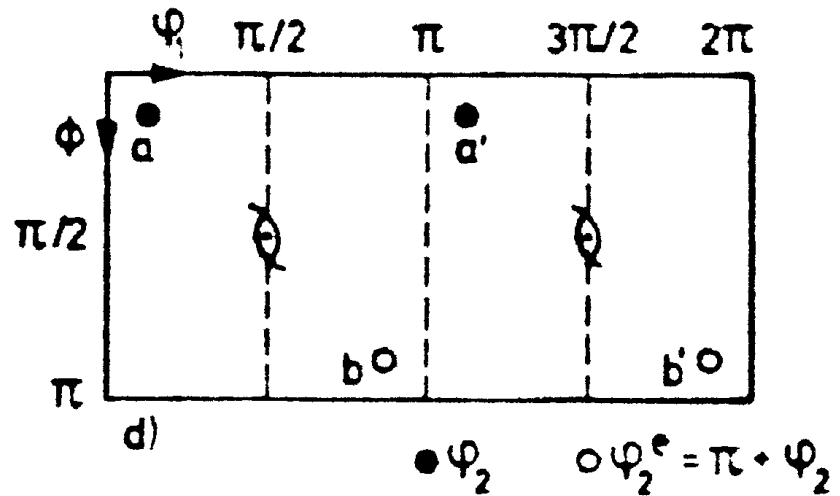
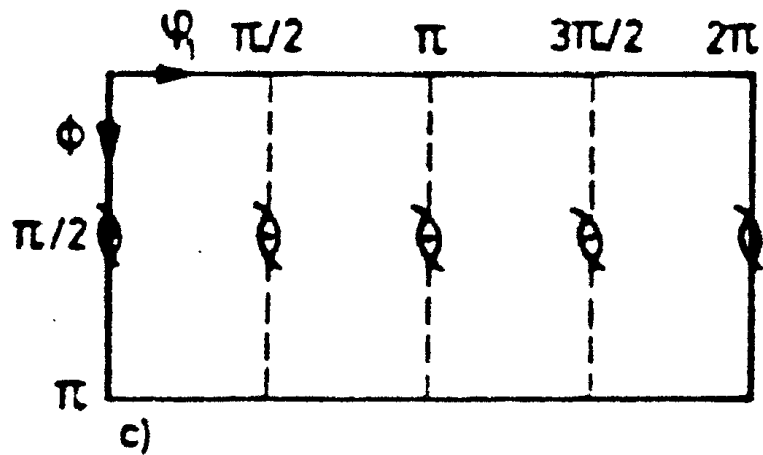
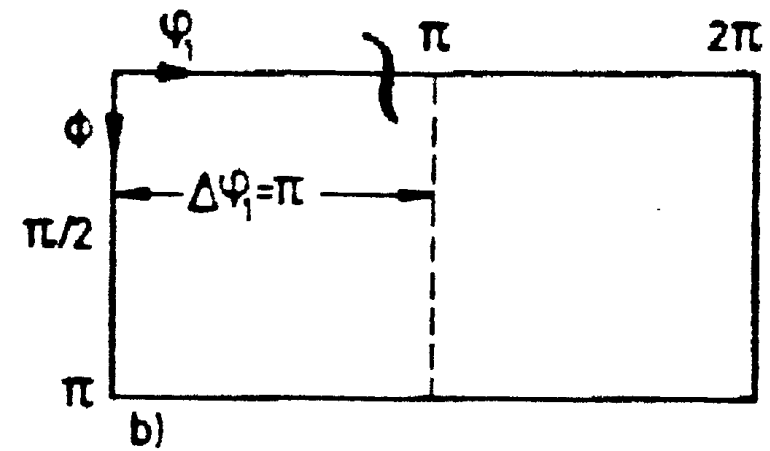
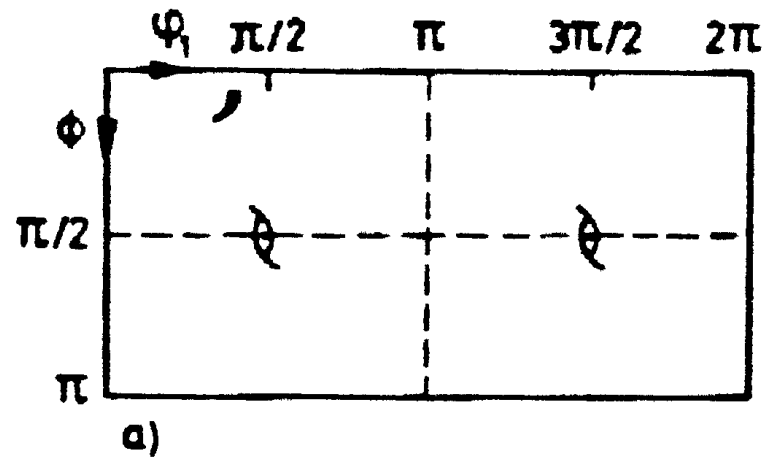

# Crystal Symmetry Relationships (432) in Euler Space

3-fold axis

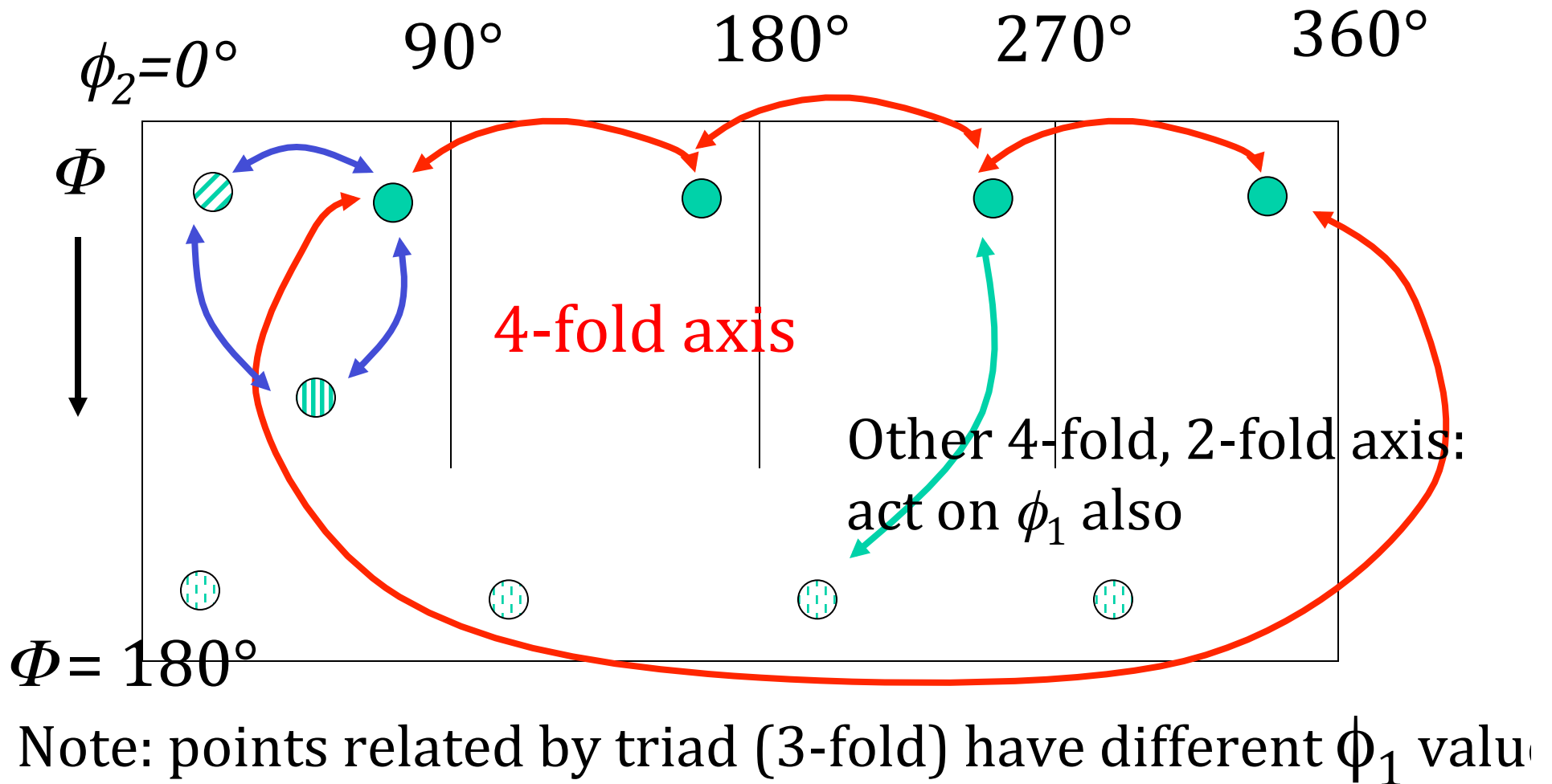



# Crystal symmetry: detail

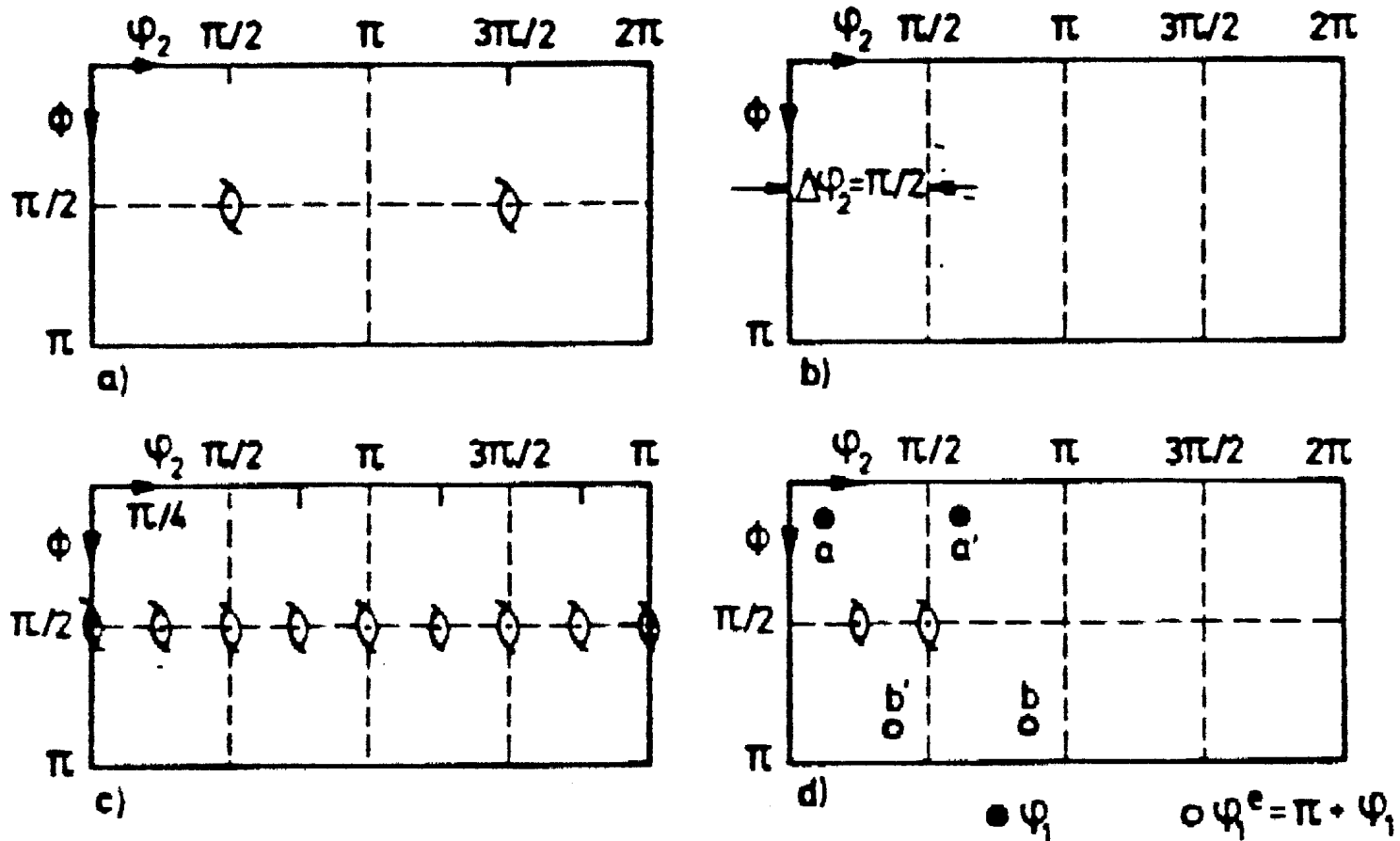

$$H' = \{0 \leq \varphi_1 \leq 2\pi, 0 \leq \phi \leq \pi/2, 0 \leq \varphi_2 \leq \pi/2\}$$

Tables for Texture Analysis of Cubic Crystals, Springer Verlag, 1978

# *How many equivalent points?*

- For cubic-orthorhombic crystal+sample symmetry, we use a range  $90^\circ \times 90^\circ \times 90^\circ$  for the three angles, giving a volume of  $90^\circ{}^2$  (or  $\pi^2/4$  in radians).
- In the (reduced) space there are *3 equivalent points for each orientation (texture component). Both sample and crystal symmetries must be combined together to find these sets.*
- If we look within the *full orientation space* then there are as many equivalent points as there are symmetry elements. Thus for cubic crystal symmetry there are 24 equivalent points; for hexagonal 12 etc.
- Fewer (e.g. Copper) *or* more (e.g. cube) equivalent points for each component are found in the *reduced space* if the the component coincides with one of the symmetry elements.

# *Volume of Orientation Space*

- $O(432)$  has 24 operators (i.e. order=24);  $O(222)$  has 4 operators (i.e. order=4): why not divide the volume of Euler space ( $8\pi^2$ , or,  $360^\circ \times 180^\circ \times 360^\circ$ ) by  $24 \times 4 = 96$  to get  $\pi^2/12$  (or,  $90^\circ \times 30^\circ \times 90^\circ$ )?
- Answer: we leave out a triad axis (because of the awkward shapes that it would give us), so we divide by  $8 \times 4 = 32$  to get  $\pi^2/4$  ( $90^\circ \times 90^\circ \times 90^\circ$ ).
- This is an illustration of group theory in action. Each set of symmetry operators divides up the orientation space by a factor equal to the number of elements in the group.
- The reason is, essentially, a question of counting: each point in one zone has exactly one point in another zone related by a given operator.

## *Group theory approach*

- Again, this is an illustration of group theory in action. Each set of symmetry operators divides up the orientation space by a factor equal to the number of elements in the group.
- Crystal symmetry:  
a combination of 4- and 2-fold crystal axes ( $2 \times 4 = 8$  elements) reduce the range of  $\Phi$  from  $\pi$  to  $\pi/2$ , and  $\phi_2$  from  $2\pi$  to  $\pi/2$ .
- Sample symmetry:  
the 2-fold sample axes (4 elements in the group) reduce the range of  $\phi_1$  from  $2\pi$  to  $\pi/2$ .
- Volume of  $\{0 \leq \phi_1, \Phi, \phi_2 \leq \pi/2\}$  is  $\pi^2/4$ .
- The reason is, essentially, a question of counting: each point in one zone has exactly one point in another zone related by a given operator.

# Special Points, Partial Fibers

No. of points in the 90x90x90° space

Copper: 2  
 Brass: 3  
 S: 3  
 Goss: 3  
 Cube: 8  
 Dillamore: 2

Why this variation?  
 Points that fall on the edge may appear more, or fewer times than the standard count of 3.

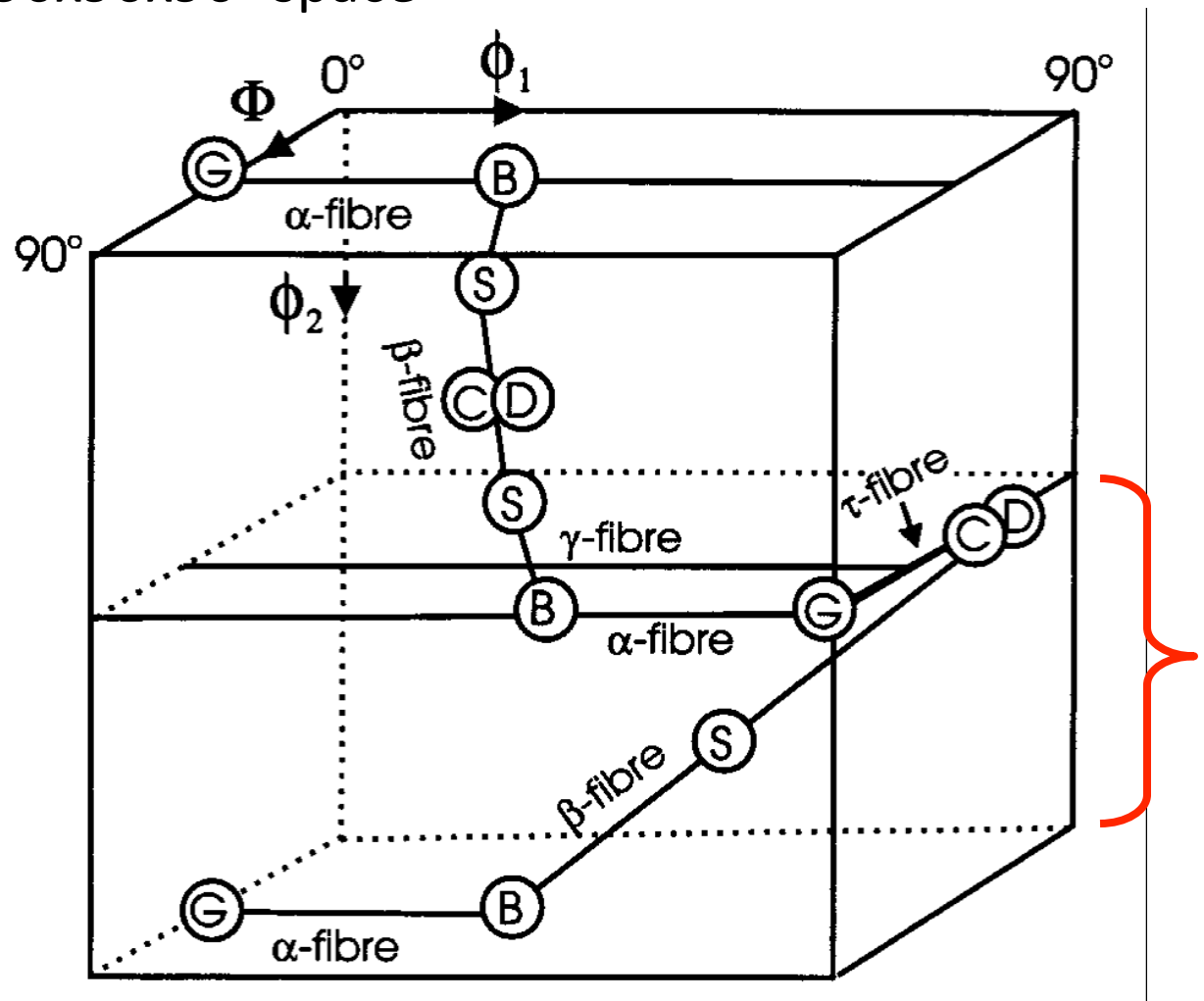

Humphreys & Hatherly

# Sample Symmetry Relationships in Euler Space: special points

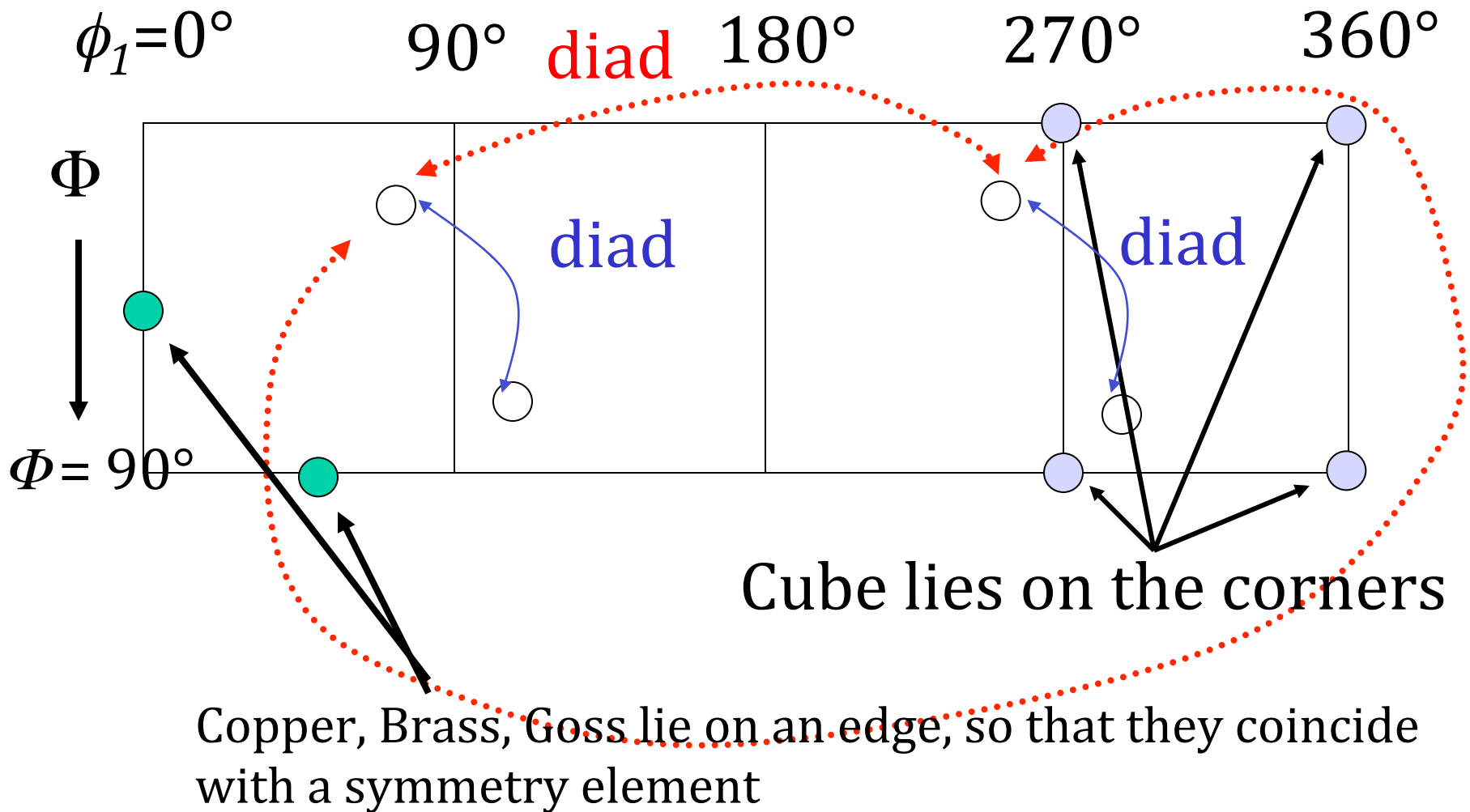

# 3D Views

a) Brass b) Copper c) S  
Goss e) Cube

f) combined texture

1: {35, 45, 90}, Brass,

2: {55, 90, 45}, Brass

3: {90, 35, 45}, Copper,

4: {39, 66, 27}, Copper

5: {59, 37, 63}, S,

6: {27, 58, 18}, S,

7: {53, 75, 34}, S

8: {90, 90, 45}, Goss

9: {0, 0, 0}, cube\*

{45, 0, 0}, rotated cube

\* Note that the cube exists as a line between (0,0,90) and (90,0,0) because of the linear dependence of the 1st and 3rd angles when the 2nd angle = 0.

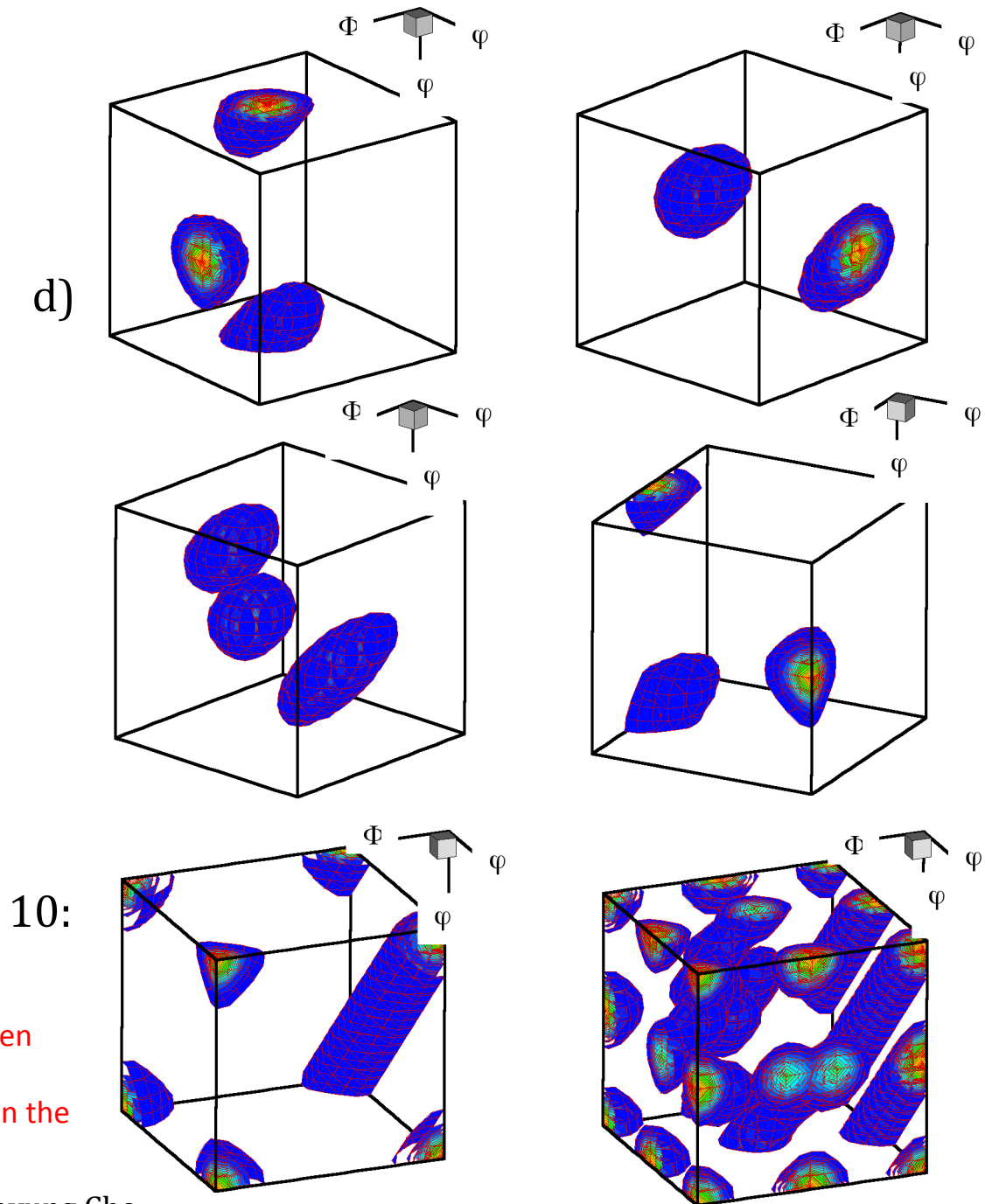

Figure courtesy of Jae-hyung Cho

## *Special Points: Explanations*

- Points coincident with symmetry axes may also have equivalent points, often on the edge. Cube: should be a single point, but each corner is equivalent and visible.
- Goss, Brass: a single point becomes 3 because it is on the  $\phi_2=0$  plane.
- Copper: 2 points because one point remains in the interior but another occurs on a face; also the Dillamore orientation.
- Note for later about volume fractions: although the volumes enclosed by the  $12^\circ$  capture (misorientation) distance shown in the figure vary with the 2<sup>nd</sup> euler angle, to first order it is the symmetry planes that control the volume fractions. So S, for example, has 3 complete “blobs” whereas Goss has only  $3 \times \frac{1}{4}$  and so will contain only  $\sim 1/4$  of the volume fraction of S, based on a random (uniform) texture.



Table 4.F.2. fcc Rolling Texture Components: Euler Angles and Indices

Name	Indices	Bunge ( $\varphi_1, \Phi, \varphi_2$ ) RD= 1	Kocks ( $\psi, \Theta, \phi$ ) RD= 1	Bunge ( $\varphi_1, \Phi, \varphi_2$ ) RD= 2	Kocks ( $\psi, \Theta, \phi$ ) RD= 2
copper/ 1 <sup>st</sup> var.	{112}<111̄>	40, 65, 26	50, 65, 26	50, 65, 64	39, 66, 63
copper/ 2 <sup>nd</sup> var.	{112}<111̄>	90, 35, 45	0, 35, 45	0, 35, 45	90, 35, 45
S3*	{123}<634>	59, 37, 27	31, 37, 27	31, 37, 63	59, 37, 63
S/ 1st var.	(312)<0 21>	32, 58, 18	58, 58, 18	26, 37, 27	64, 37, 27
S/ 2nd var.	(312)<0 21>	48, 75, 34	42, 75, 34	42, 75, 56	48, 75, 56
S/ 3rd var.	(312)<0 21>	64, 37, 63	26, 37, 63	58, 58, 72	32, 58, 72
brass/ 1 <sup>st</sup> var.	{110}<1̄12>	35, 45, 0	55, 45, 0	55, 45, 0	35, 45, 0
brass/ 2 <sup>nd</sup> var.	{110}<1̄12>	55, 90, 45	35, 90, 45	35, 90, 45	55, 90, 45
brass/ 3 <sup>rd</sup> var.	{110}<1̄12>	35, 45, 90	55, 45, 90	55, 45, 90	35, 45, 90
Taylor	{4 4 11}<11 11 8̄>	42, 71, 20	48, 71, 20	48, 71, 70	42, 71, 70
Taylor/ 2nd var.	{4 4 11}<11 11 8̄>	90, 27, 45	0, 27, 45	0, 27, 45	90, 27, 45
Goss/ 1 <sup>st</sup> var.	{110}<001>	0, 45, 0	90, 45, 0	90, 45, 0	0, 45, 0
Goss/ 2 <sup>nd</sup> var.	{110}<001>	90, 90, 45	0, 90, 45	0, 90, 45	90, 90, 45
Goss/ 3 <sup>rd</sup> var.	{110}<001>	0, 45, 90	90, 45, 90	90, 45, 90	0, 45, 90

[Kocks,  
Tomé,  
Wenk]

## *Meaning of “Variants”*

- The existence of variants of a given texture component is a consequence of (statistical) *sample symmetry*.
- If one permutes the Miller indices for a given component (for cubics, one can change the sign and order, but not the set of digits), then different values of the Euler angles are found for each permutation.
- If a pole figure is plotted of *all* the variants, one observes a number of physically distinct orientations, which are related to each other by symmetry operators (diads, typically) fixed in the sample frame of reference.
- Each physically distinct orientation is a “variant”. The number of variants listed depends on the choice of size of Euler space (typically  $90 \times 90 \times 90^\circ$ ) and the alignment of the component with respect to the sample symmetry.

## *Part 2: Quantitative*

- In part 2 of the lecture, we describe the methods for describing symmetry operations as rotation matrices and how to apply them to texture components, also expressed as matrices.
- Notation:  
orientation:  $g$   
(crystal) symmetry operator:  $O_C$   
(sample) symmetry operator:  $O_S$

# *Rotations: definitions*

- Rotational symmetry elements exist whenever you can rotate a physical object and result is indistinguishable from what you started out with.
- Rotations can be expressed in a simple mathematical form as unimodular matrices (or, *orthogonal matrices*), often with elements that are usually either one or zero (but not always!).
- When represented as matrices, the inverse of a rotation is equal to the transpose of the matrix.
- Rotations are transformations of the *first kind*; determinant = +1.
- Reflections (not needed here) are transformations of the *second kind*; determinant = -1.
- Crystal symmetry also can involve translations but these are not included in this treatment.

# *Rotation Matrix from Axis-Angle Pair*

Written out as a complete 3x3 matrix:

$$\begin{aligned}
 g_{ij} &= \delta_{ij} \cos \theta + r_i r_j (1 - \cos \theta) \\
 &\quad + \sum_{k=1,3} \varepsilon_{ijk} r_k \sin \theta \\
 &= \begin{pmatrix} \cos \theta + u^2 (1 - \cos \theta) & uv(1 - \cos \theta) + w \sin \theta & uw(1 - \cos \theta) - v \sin \theta \\ uv(1 - \cos \theta) - w \sin \theta & \cos \theta + v^2 (1 - \cos \theta) & vw(1 - \cos \theta) + u \sin \theta \\ uw(1 - \cos \theta) + v \sin \theta & vw(1 - \cos \theta) - u \sin \theta & \cos \theta + w^2 (1 - \cos \theta) \end{pmatrix}
 \end{aligned}$$

# *Symmetry Operator examples*

- Diad on z:  $[uvw] = [001]$ ,  $\theta = 180^\circ$  -  
substitute the values of  $uvw$  and angle into  
the formula

$$g_{ij} = \begin{pmatrix} \cos 180 + 0^2(1 - \cos 180) & 0 * 0(1 - \cos 180) + 1 * \sin 180 & 0 * 1(1 - \cos 180) - 0 \sin 180 \\ 0 * 0(1 - \cos 180) - 0 \sin 180 & \cos 180 + 0^2(1 - \cos 180) & 0 * 1(1 - \cos 180) + 0 \sin 180 \\ 0 * 1(1 - \cos 180) + 0 \sin 180 & 0 * 1(1 - \cos 180) - 0 \sin 180 & \cos 180 + 1^2(1 - \cos 180) \end{pmatrix} = \begin{pmatrix} -1 & 0 & 0 \\ 0 & -1 & 0 \\ 0 & 0 & 1 \end{pmatrix}$$

- 4-fold on x:  
 $[uvw] = [100]$   
 $\theta = 90^\circ$

$$g_{ij} = \begin{pmatrix} \cos 90 + 1^2(1 - \cos 90) & 1 * 0(1 - \cos 90) + w \sin 90 & 0 * 1(1 - \cos 90) - 0 \sin 90 \\ 0 * 1(1 - \cos 90) - 0 \sin 90 & \cos 90 + 0^2(1 - \cos 90) & 1 * 0(1 - \cos 90) + 1 \sin 90 \\ 0 * 1(1 - \cos 90) + 0 \sin 90 & 0 * 0(1 - \cos 90) - 1 \sin 90 & \cos 90 + 0^2(1 - \cos 90) \end{pmatrix} = \begin{pmatrix} 1 & 0 & 0 \\ 0 & 0 & 1 \\ 0 & -1 & 0 \end{pmatrix}$$

# Matrix representation of the rotation point groups

What is a *group*? A group is a set of objects that form a closed set: if you combine any two of them together, the result is simply a different member of that same group of objects. Rotations in a given point group form closed sets - try it for yourself!

Note: the 3rd matrix in the 1st column (x-diad) is missing a "-" on the 33 element; this is corrected in this slide. Also, in the 2nd from the bottom, last column: the 33 element should be +1, not -1. In some versions of the book, in the last matrix (bottom right corner) the 33 element is incorrectly given as -1; here the +1 is correct.

The 4 operators enclosed in orange boxes are also the 222 point group, appropriate to orthorhombic symmetry

Table II. Symmetry operators of rotation groups

tetragonal branch	hexagonal branch	cubic branch																																				
<table border="1"> <tr><td>1</td><td>1</td><td>0</td><td>0</td></tr> <tr><td>0</td><td>0</td><td>1</td><td>0</td></tr> <tr><td>0</td><td>0</td><td>0</td><td>1</td></tr> </table>	1	1	0	0	0	0	1	0	0	0	0	1	<table border="1"> <tr><td>1</td><td>0</td><td>0</td></tr> <tr><td>0</td><td>1</td><td>0</td></tr> <tr><td>0</td><td>0</td><td>1</td></tr> </table>	1	0	0	0	1	0	0	0	1	<table border="1"> <tr><td>1</td><td>0</td><td>0</td></tr> <tr><td>0</td><td>1</td><td>0</td></tr> <tr><td>0</td><td>0</td><td>1</td></tr> </table>	1	0	0	0	1	0	0	0	1						
1	1	0	0																																			
0	0	1	0																																			
0	0	0	1																																			
1	0	0																																				
0	1	0																																				
0	0	1																																				
1	0	0																																				
0	1	0																																				
0	0	1																																				
<table border="1"> <tr><td>2</td><td>-1</td><td>0</td><td>0</td></tr> <tr><td>0</td><td>0</td><td>1</td><td>0</td></tr> <tr><td>0</td><td>0</td><td>0</td><td>-1</td></tr> </table>	2	-1	0	0	0	0	1	0	0	0	0	-1	<table border="1"> <tr><td>-5</td><td>a</td><td>0</td></tr> <tr><td>-a</td><td>.5</td><td>0</td></tr> <tr><td>0</td><td>0</td><td>1</td></tr> </table>	-5	a	0	-a	.5	0	0	0	1	<table border="1"> <tr><td>0</td><td>0</td><td>1</td></tr> <tr><td>1</td><td>0</td><td>0</td></tr> <tr><td>0</td><td>1</td><td>0</td></tr> </table>	0	0	1	1	0	0	0	1	0						
2	-1	0	0																																			
0	0	1	0																																			
0	0	0	-1																																			
-5	a	0																																				
-a	.5	0																																				
0	0	1																																				
0	0	1																																				
1	0	0																																				
0	1	0																																				
<table border="1"> <tr><td>222</td><td>1</td><td>0</td><td>0</td></tr> <tr><td>0</td><td>-1</td><td>0</td><td>0</td></tr> <tr><td>0</td><td>0</td><td>0</td><td>-1</td></tr> </table>	222	1	0	0	0	-1	0	0	0	0	0	-1	<table border="1"> <tr><td>3</td><td>-5</td><td>a</td><td>0</td></tr> <tr><td>-a</td><td>.5</td><td>0</td><td>0</td></tr> <tr><td>0</td><td>0</td><td>1</td><td>0</td></tr> </table>	3	-5	a	0	-a	.5	0	0	0	0	1	0	<table border="1"> <tr><td>0</td><td>1</td><td>0</td></tr> <tr><td>0</td><td>0</td><td>1</td></tr> <tr><td>1</td><td>0</td><td>0</td></tr> </table>	0	1	0	0	0	1	1	0	0			
222	1	0	0																																			
0	-1	0	0																																			
0	0	0	-1																																			
3	-5	a	0																																			
-a	.5	0	0																																			
0	0	1	0																																			
0	1	0																																				
0	0	1																																				
1	0	0																																				
<table border="1"> <tr><td>42</td><td>0</td><td>1</td><td>0</td></tr> <tr><td>-1</td><td>0</td><td>0</td><td>0</td></tr> <tr><td>0</td><td>0</td><td>0</td><td>1</td></tr> </table>	42	0	1	0	-1	0	0	0	0	0	0	1	<table border="1"> <tr><td>6</td><td>-1</td><td>0</td><td>0</td></tr> <tr><td>0</td><td>0</td><td>-1</td><td>0</td></tr> <tr><td>0</td><td>0</td><td>0</td><td>1</td></tr> </table>	6	-1	0	0	0	0	-1	0	0	0	0	1	<table border="1"> <tr><td>0</td><td>-1</td><td>0</td></tr> <tr><td>0</td><td>0</td><td>-1</td></tr> <tr><td>1</td><td>0</td><td>0</td></tr> </table>	0	-1	0	0	0	-1	1	0	0			
42	0	1	0																																			
-1	0	0	0																																			
0	0	0	1																																			
6	-1	0	0																																			
0	0	-1	0																																			
0	0	0	1																																			
0	-1	0																																				
0	0	-1																																				
1	0	0																																				
<table border="1"> <tr><td>0</td><td>1</td><td>0</td></tr> <tr><td>1</td><td>0</td><td>0</td></tr> <tr><td>0</td><td>0</td><td>-1</td></tr> </table>	0	1	0	1	0	0	0	0	-1	<table border="1"> <tr><td>-5</td><td>-a</td><td>0</td></tr> <tr><td>-a</td><td>.5</td><td>0</td></tr> <tr><td>0</td><td>0</td><td>-1</td></tr> </table>	-5	-a	0	-a	.5	0	0	0	-1	<table border="1"> <tr><td>0</td><td>1</td><td>0</td></tr> <tr><td>0</td><td>0</td><td>-1</td></tr> <tr><td>-1</td><td>0</td><td>0</td></tr> </table>	0	1	0	0	0	-1	-1	0	0									
0	1	0																																				
1	0	0																																				
0	0	-1																																				
-5	-a	0																																				
-a	.5	0																																				
0	0	-1																																				
0	1	0																																				
0	0	-1																																				
-1	0	0																																				
<table border="1"> <tr><td>0</td><td>-1</td><td>0</td></tr> <tr><td>-1</td><td>0</td><td>0</td></tr> <tr><td>0</td><td>0</td><td>-1</td></tr> </table>	0	-1	0	-1	0	0	0	0	-1	<table border="1"> <tr><td>622</td><td>1</td><td>0</td><td>0</td></tr> <tr><td>0</td><td>-1</td><td>0</td><td>0</td></tr> <tr><td>0</td><td>0</td><td>-1</td><td>0</td></tr> </table>	622	1	0	0	0	-1	0	0	0	0	-1	0	<table border="1"> <tr><td>0</td><td>0</td><td>-1</td></tr> <tr><td>-1</td><td>0</td><td>0</td></tr> <tr><td>0</td><td>1</td><td>0</td></tr> </table>	0	0	-1	-1	0	0	0	1	0						
0	-1	0																																				
-1	0	0																																				
0	0	-1																																				
622	1	0	0																																			
0	-1	0	0																																			
0	0	-1	0																																			
0	0	-1																																				
-1	0	0																																				
0	1	0																																				
<table border="1"> <tr><td>a = <math>\sqrt{3}/2</math></td><td>.5</td><td>a</td><td>0</td></tr> <tr><td></td><td>a</td><td>-.5</td><td>0</td></tr> <tr><td></td><td>0</td><td>0</td><td>-1</td></tr> </table>	a = $\sqrt{3}/2$	.5	a	0		a	-.5	0		0	0	-1	<table border="1"> <tr><td>622</td><td>-1</td><td>0</td><td>0</td></tr> <tr><td>0</td><td>1</td><td>0</td><td>0</td></tr> <tr><td>0</td><td>0</td><td>-1</td><td>0</td></tr> </table>	622	-1	0	0	0	1	0	0	0	0	-1	0	<table border="1"> <tr><td>23</td><td>1</td><td>0</td><td>0</td></tr> <tr><td>0</td><td>-1</td><td>0</td><td>0</td></tr> <tr><td>0</td><td>0</td><td>1</td><td>0</td></tr> </table>	23	1	0	0	0	-1	0	0	0	0	1	0
a = $\sqrt{3}/2$	.5	a	0																																			
	a	-.5	0																																			
	0	0	-1																																			
622	-1	0	0																																			
0	1	0	0																																			
0	0	-1	0																																			
23	1	0	0																																			
0	-1	0	0																																			
0	0	1	0																																			
	<table border="1"> <tr><td>622</td><td>.5</td><td>-a</td><td>0</td></tr> <tr><td></td><td>-a</td><td>.5</td><td>0</td></tr> <tr><td></td><td>0</td><td>0</td><td>-1</td></tr> </table>	622	.5	-a	0		-a	.5	0		0	0	-1	<table border="1"> <tr><td>432</td><td>0</td><td>1</td><td>0</td></tr> <tr><td></td><td>-1</td><td>0</td><td>0</td></tr> <tr><td></td><td>0</td><td>0</td><td>1</td></tr> </table>	432	0	1	0		-1	0	0		0	0	1	<table border="1"> <tr><td>0</td><td>1</td><td>0</td></tr> <tr><td>0</td><td>0</td><td>1</td></tr> <tr><td>1</td><td>0</td><td>0</td></tr> </table>	0	1	0	0	0	1	1	0	0		
622	.5	-a	0																																			
	-a	.5	0																																			
	0	0	-1																																			
432	0	1	0																																			
	-1	0	0																																			
	0	0	1																																			
0	1	0																																				
0	0	1																																				
1	0	0																																				

The dashed boxes in this column make up group 4.

The dashed boxes in this column make up group 32.

The dashed box in this column comprises the 3-fold axes only.

# *Nomenclature for rotation elements*

- In general, the notation identifies the axis about which the rotation is performed.
- Thus a 2-fold axis ( $180^\circ$  rotation) about the z-axis is known as a z-diad, or  $C_{2z}$ , or  $L_{001}^2$
- Triad ( $120^\circ$  rotation) about  $[111]$  as a 111-triad, or,  
 $120^\circ$ - $\langle 111 \rangle$ , or,  $L_{111}^3$  etc.
- A point group is written as  $O(432)$ , for example, where the entry in the parentheses indicates the symmetry.

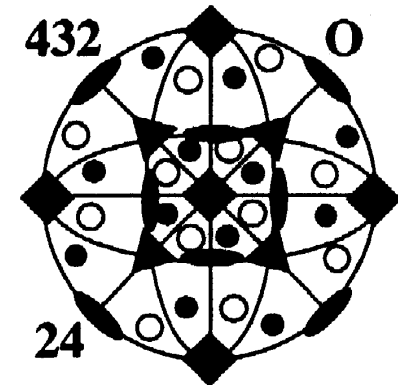



## *How to use a symmetry operator?*

1. Convert Miller indices that represent an orientation or texture component to a (orientation) matrix.
2. Perform matrix multiplication with the symmetry operator,  $O_c$ , and the orientation matrix,  $g$ , to obtain the new orientation (matrix),  $g'$ . Be careful to get the order correct! For the standard coordinate/axis transformation used here, the crystal symmetry operator always left-multiplies (pre-multiplies) the orientation. Since the orientation matrix converts from sample to crystal axes, you can think of applying crystal symmetry *after* transforming a quantity into the crystal frame.

$$g' = O_c g$$

3. Convert the matrix back to Miller indices.
4. The two sets of indices represent (for crystal symmetry) indistinguishable objects.

# Example

$$g' = O_c g$$

Goss: (011)[100]:

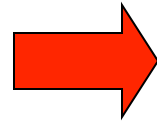

$$\begin{pmatrix} 1 & 0 & g \\ 0 & 1/\sqrt{2} & 1/\sqrt{2} \\ 0 & -1/\sqrt{2} & 1/\sqrt{2} \end{pmatrix}$$

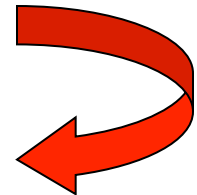

Pre-multiply by z-diad:

$$O_c \begin{pmatrix} 1 & 0 & 0 \\ 0 & 1/\sqrt{2} & 1/\sqrt{2} \\ 0 & -1/\sqrt{2} & 1/\sqrt{2} \end{pmatrix} = \begin{pmatrix} -1 & 0 & 0 \\ 0 & -1 & 0 \\ 0 & 0 & 1 \end{pmatrix} \begin{pmatrix} 1 & 0 & 0 \\ 0 & 1/\sqrt{2} & 1/\sqrt{2} \\ 0 & -1/\sqrt{2} & 1/\sqrt{2} \end{pmatrix}$$

$$= \begin{pmatrix} -1 & 0 & 0 \\ 0 & -1/\sqrt{2} & -1/\sqrt{2} \\ 0 & -1/\sqrt{2} & 1/\sqrt{2} \end{pmatrix} g'$$

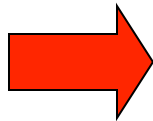

which is (0-11)[-100]

Sample symmetry: right multiply (post-multiply) the matrix.

*Crystal  
symmetry  
O(432)  
acting on the  
(231)[3-46] S  
component*

Euler angles: (52.9, 74.5, 33.7)

Note that all 24  
variants are  
present

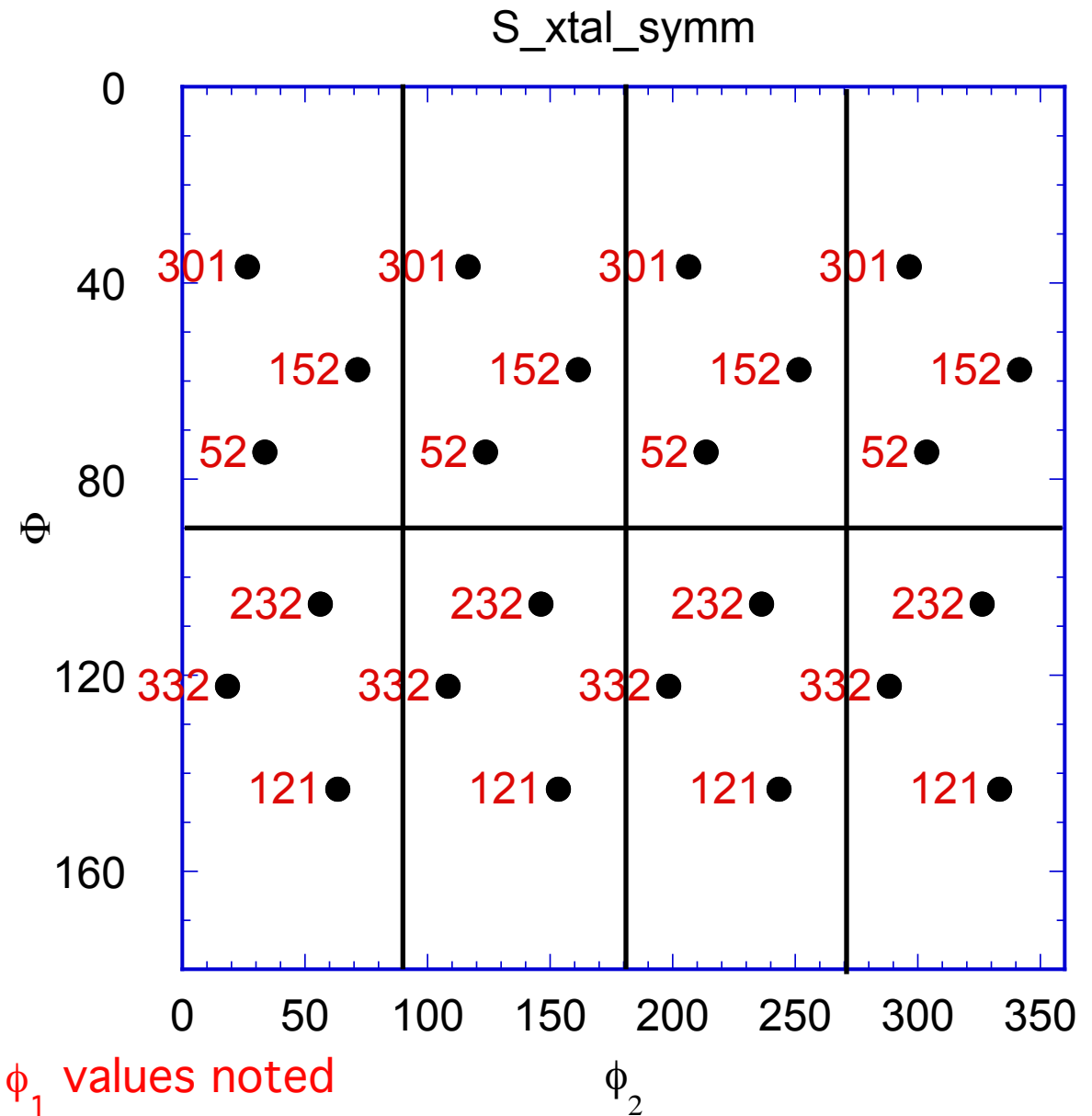

Homework exercise: you can make this same plot by using, e.g., Matlab to compute the matrix of each symmetrically equivalent orientation and then converting each new matrix to Euler angles; then use “scatter3” to plot in 3D.

## *Order of Matrices*

- Assume that we are using the standard *axis transformation (passive rotation)* definition of orientation (as found, e.g. in Bunge's book).
- Order depends on whether *crystal* or *sample* symmetry elements are applied.
- For an operator in the crystal system,  $O_{xtal}$ , the operator pre-multiplies the orientation matrix.
- Think of the sequence as first transform into crystal coordinates, then apply crystal symmetry once you are in crystal coordinates.
- For sample operator,  $O_{sample}$ , post-multiply the orientation matrix.

# Symmetry Relationships

- Note that the result of applying any available operator is equivalent to (physically indistinguishable in the case of crystal symmetry) from the starting configuration (not mathematically equal to!).
- Also, if you apply a sample symmetry operator, the result is generally physically different from the starting position. Why?! Because the sample symmetry is only a *statistical symmetry*, not an exact, physical symmetry.
- Do not confuse this with the standard expression for the transformation of a second rank tensor:  $T' = OTOT^T$

$$g' = O_{crystal} g O_{sample} \longleftrightarrow g$$

NB: if one writes an orientation as an *active rotation* (as in continuum mechanics), then the order of application of symmetry operators is reversed: premultiply by sample, and postmultiply by crystal symmetry!

# *Symmetry: How-to*

- How to find all the symmetrically equivalent points?
- Convert the component of interest to matrix notation.
- Make a list of all the symmetry operators in matrix form (24 for cubic crystal symmetry or 12 for hexagonal crystal symmetry, and 4 for orthorhombic sample symmetry). This is the same list of operators shown as 3x3 matrices in the Table quoted from the Kocks book, slide 35 in this set.
- Crystal symmetry: identity (1), plus 90/180/270° about  $\langle 100 \rangle$  (9), plus 180° about  $\langle 110 \rangle$  (6), plus 120/240° about  $\langle 111 \rangle$  (8).
- Sample symmetry: identity, plus 180° about RD/TD/ND (4).
- Loop through each symmetry operator in turn, with separate loops for sample and crystal symmetry.
- For each result, convert the matrix to Euler angles.
- How can you be sure that you have applied the operators correctly? Answer: make a pole figure of the set of symmetrically related orientations. Crystal symmetry related points must plot on top of one another whereas sample symmetry related points give rise to (in general) multiple sets of points, related by the sample symmetry that should be evident in the pole figure.

# Crystal Symmetry Correctly Applied

- If you start with the Goss orientation and apply crystal symmetry by left-multiplying, you should obtain pole figures like this. The application of crystal symmetry did *not* produce any new orientations as far as the pole figure is concerned. Note that x (//RD) points right in this example.

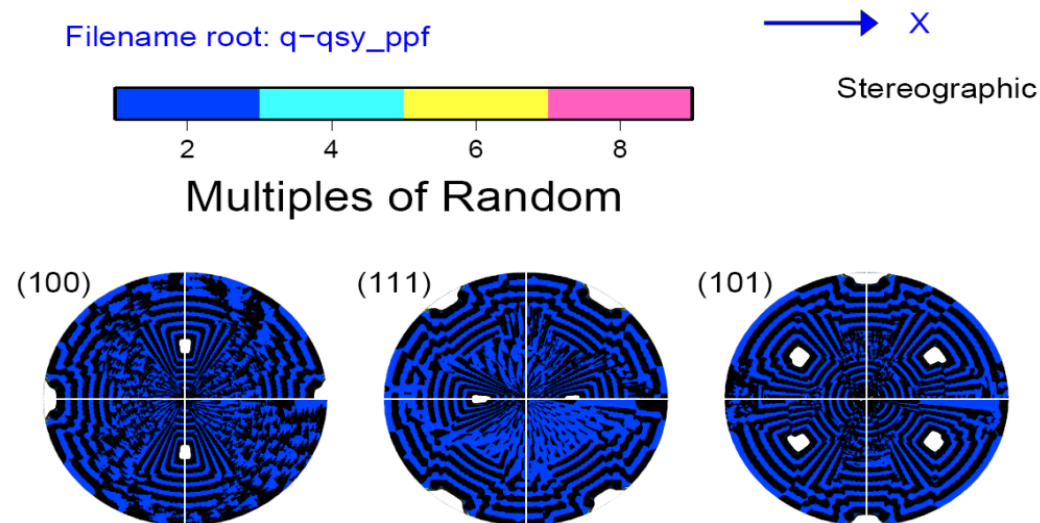

*Plots courtesy of Vahid Tari, 2011*

# Crystal Symmetry *Incorrectly* Applied

- If you start with the Goss orientation and apply crystal symmetry by right-multiplying, you should obtain pole figures like this. The application of crystal symmetry *does* produce new orientations in the pole figures but this *incorrect*. The result of applying crystal symmetry must be indistinguishable from the initial state. Note that x points right in this example.

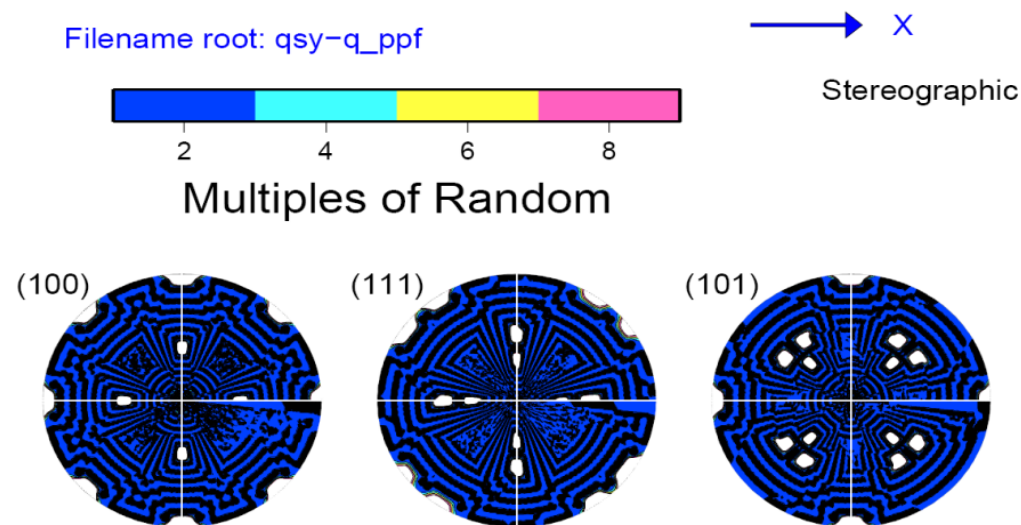

*Plots courtesy of Vahid Tari, 2011*



# *Texture Component Variants*

- Variants of a given texture component share Miller indices that are the same except for whatever variations are allowed by crystal symmetry. This results in orientations that are usually, but not invariably, different i.e. have finite misorientations between them.
- To obtain a set of variants, one applies the appropriate set of sample symmetry operators to a single orientation that defines the component, e.g. from a pair of Miller indices for  $hkl//ND$ ,  $uvw//RD$ . For orthorhombic sample symmetry, for example,  $\{O_{\text{sample}}\} = O(222)$  which has four operators, so there are a maximum of four variants.
- As a consequence of the way that each component aligns with the sample symmetry operators, the cube and Goss components have only one variant, the copper and brass have two, whereas the S component has all four variants.

$$\{g\}_{\text{variants}} = g \left\{ O_{\text{sample}} \right\}$$

# *Summary*

- Symmetry operators have been explained in terms of rotation matrices, with examples of how to construct them from the axis-angle descriptions.
- The effect of symmetry on the range of Euler angles needed, and the shape of the plotting region.
- The particular effect of symmetry on certain named texture components found in rolled fcc metals has been described.
- In later lectures, we will see how to perform the same operations but with or on Rodrigues vectors and quaternions.

## *Supplemental Slides*

- The following slides provide:
- Details of the range of Euler angles, and the shape of the plotting space required for CODs (crystallite orientation distributions) or SODs (sample orientation distributions) as a function of the crystal symmetry;
- Additional information about the details of how symmetry elements relate different locations in Euler space.

# Axis Transformation from Axis-Angle Pair

- Since crystal symmetry operators are closely linked to low index directions, it is helpful to convert axis-angle descriptions to matrices and vice versa.
- The rotation can be converted to a matrix,  $g$ , (*passive* rotation) by the following expression, where  $\delta$  is the Kronecker delta,  $\theta$  is the rotation angle,  $r$  is the rotation axis, and  $\varepsilon$  is the permutation tensor.

## Rotations (Active): Axis-Angle Pair

A rotation is commonly written as  $(\hat{r}, \theta)$  or as  $(\mathbf{n}, \omega)$ . The figure illustrates the effect of a rotation about an arbitrary axis, OQ (equivalent to  $\hat{r}$  and  $\mathbf{n}$ ) through an angle  $\alpha$  (equivalent to  $\theta$  and  $\omega$ ).

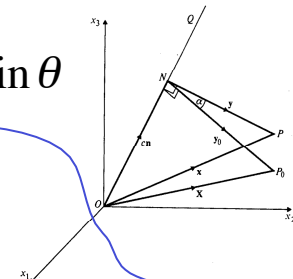
$$g_{ij} = \delta_{ij} \cos \theta - \varepsilon_{ijk} n_k \sin \theta + (1 - \cos \theta) n_i n_j$$

(This is an *active* rotation: a *passive* rotation = axis transformation)

$$g_{ij} = \delta_{ij} \cos \theta + r_i r_j (1 - \cos \theta) + \sum_{k=1,3} \varepsilon_{ijk} r_k \sin \theta$$

Compare with *active* rotation matrix!

*Sample Symmetry Element*  
*e.g. diad on ND*  
*(associated with  $\phi_1$ )*

*Crystal Symmetry Element*  
*e.g. rotation on  $[001]$*   
*(associated with  $\phi_2$ )*

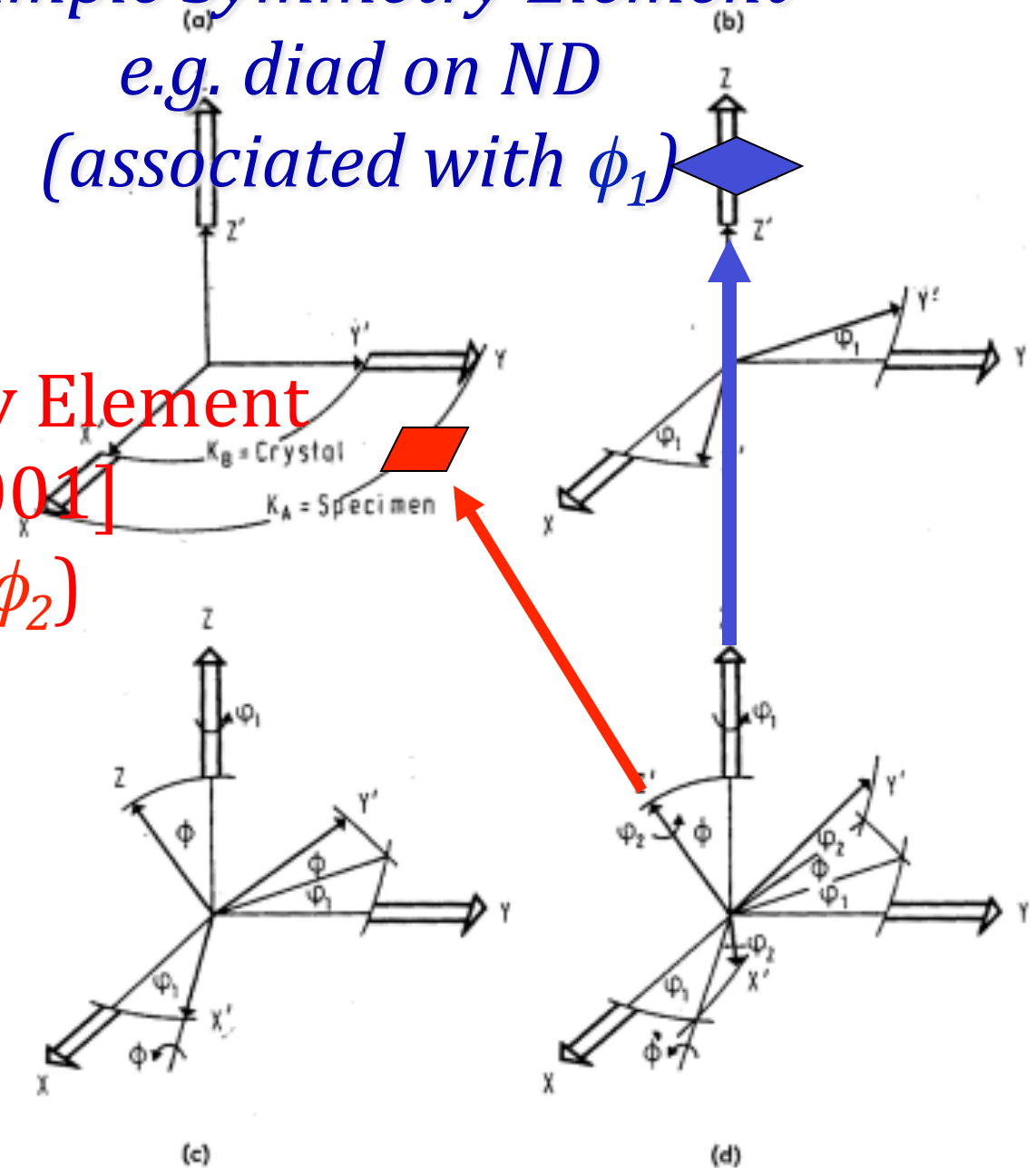

[Bunge]

[Kocks]

Table of Effect of Symmetry Elements on Eul

Symmetry Element	Bunge		
2-fold axis on Sample X	$\pi - \phi_1$	$\pi - \Phi$	$\phi_2 \pm \pi$
2-fold axis on Sample Y	$-\phi_1$	$\pi - \Phi$	$\phi_2 \pm \pi$
2-fold axis on Sample Z	$\phi_1 - \pi$	$\Phi$	$\phi_2$
2-fold axis on Crystal x	$\phi_1 \pm \pi$	$\pi - \Phi$	$\pi - \phi_2$
2-fold axis on Crystal y	$\phi_1 \pm \pi$	$\pi - \Phi$	$-\phi_2$
2-fold axis on Crystal z	$\phi_1$	$\Phi$	$\phi_2 \pm \pi$
3-fold axis on Crystal z	$\phi_1$	$\Phi$	$\phi_2 \pm 2\pi/3$
4-fold axis on Crystal z	$\phi_1$	$\Phi$	$\phi_2 \pm \pi/2$
6-fold axis on Crystal z	$\phi_1$	$\Phi$	$\phi_2 \pm \pi/3$

These are simple cases: see detailed charts at the end of this set of slides

## *Other symmetry operators*

- Symmetry operators of the *second kind*: these operators include the inversion center and mirrors; determinant = -1.
- The inversion (= center of symmetry) simply reverses any vector so that  $(x,y,z) \rightarrow (-x,-y,-z)$ .
- Mirrors operate through a mirror axis. Thus an x-mirror is a mirror in the plane  $x=0$  and has the effect  $(x,y,z) \rightarrow (-x,y,z)$ .

# *Examples of symmetry operators*

- Diad on z:  
(1st kind)

$$\begin{pmatrix} -1 & 0 & 0 \\ 0 & -1 & 0 \\ 0 & 0 & 1 \end{pmatrix}$$

Inversion  
Center:  
(2nd kind)

- Mirror on x:  
(2nd kind)

$$\begin{pmatrix} -1 & 0 & 0 \\ 0 & 1 & 0 \\ 0 & 0 & 1 \end{pmatrix}$$

$$\begin{pmatrix} -1 & 0 & 0 \\ 0 & -1 & 0 \\ 0 & 0 & -1 \end{pmatrix}$$



## *How many equivalent points?*

- Each symmetry operator relates a pair of points in orientation (Euler) space.
- Therefore each operator divides the available space by a factor of the order of the rotation axis. In fact, the **order** of group is significant. If there are four symmetry operators in the group, then the size of orientation space is decreased by four.
- This suggests that the orientation space is smaller than the general space by a factor equal to the number of general poles.

# Crystallite Orientation Distribution

Sections at constant  
values of the third angle

Kocks: Ch. 2 fig. 36

## CRYSTAL ORIENTATION DISTRIBUTION

SAMPLE SYMMETRY: Section shape

Orthotropic<sup>†</sup>

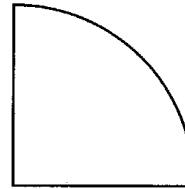

Z-diad or Y-plane

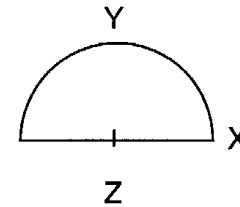

General

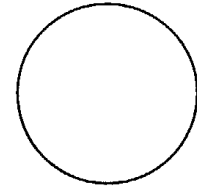

## CRYSTAL SYMMETRY

Laue group		Section range		Multiplicity
		COD	Oblique sections	
Cubic	m3m	90°	45°	3
	m3	180°	90°	3
Tetragonal	4/mmm	90°	45°	1
	4/m	180°	90°	1
Orthorhombic	mmm	180°	90°	1
Hexagonal	6/mmm	60°	30°	1
	6/m	120°	60°	1
Trigonal	$\bar{3}/m$	120°	60°	1
	$\bar{3}$	240°	120°	1
Monoclinic	2/m	360°	180°	1
Triclinic	$\bar{1}$	—	360°	1

<sup>†</sup>It is sometimes advantageous to use a semi-circle and cut the section range in half.

# Sample Orientation Distribution

Sections at constant values of the first angle

Kocks: Ch. 2 fig. 37

SAMPLE ORIENTATION DISTRIBUTION

CRYSTAL SYMM.		SAMPLE SYMMETRY				
Crystal system	Laue group	Orthotropic	SOD range†	Other	SOD range for Z-diad or Y-diad*	General†
Cubic	m3m		90°			360°
	m3m		180°		360°	360°
Tetragonal	4/mmm		90°		180°	360°
			180°		360°	360°
Orthorhombic	4/m	y	90°		90°	180°
	mmm		90°		90°	180°
Monoclinic	2/m		180°		180°	360°
Hexagonal	6/mmm		90°		180°	360°
			180°		180° Δ	360° Δ
Trigonal	3m		180°		180° Δ	360° Δ
			180°		180° Δ	360° Δ
Triclinic	$\bar{3}$		90° Δ		180° Δ	360° Δ
	$\bar{1}$		180°		360°	—

† Range for oblique sections is half this value

\* For an X-diad, the range 90° to 270° suffices

Δ Multiplicity 3/2

Table 3.5: Symmetry elements in the Euler's angle space for different sample symmetries (in the triclinic and monoclinic case only the true space symmetries are listed, i.e. Mirror lines and mirror points are omitted).

Triclinic	Orthorhombic
<p>1. translation <math>\Delta\varphi_2 = \pi/2</math></p> $\begin{pmatrix} 0 \\ 0 \\ \pi/2 \end{pmatrix} + E \quad \begin{array}{l} \varphi_1^e = \varphi_1 \\ \phi^e = \phi \\ \varphi_2^e = \varphi_2 + \pi/2 \end{array}$	<p>1. translation <math>\Delta\varphi_1 = \pi</math></p> $\begin{pmatrix} \pi \\ 0 \\ 0 \end{pmatrix} + E \quad \begin{array}{l} \varphi_1^e = \varphi_1 + \pi \\ \phi^e = \phi \\ \varphi_2^e = \varphi_2 \end{array}$
<p>2. two-fold screw axis</p> $\begin{pmatrix} \pi \\ \pi \\ \pi/2 \end{pmatrix} + L_{\varphi_1}^2 \quad \begin{array}{l} \varphi_1^e = \pi + \varphi_1 \\ \phi^e = \pi - \phi \\ \varphi_2^e = \pi/2 - \varphi_2 \end{array}$	<p>2. translation <math>\Delta\varphi_2 = \pi/2</math></p> $\begin{pmatrix} 0 \\ 0 \\ \pi/2 \end{pmatrix} + E \quad \begin{array}{l} \varphi_1^e = \varphi_1 \\ \phi^e = \phi \\ \varphi_2^e = \varphi_2 + \pi/2 \end{array}$
<p>3. glide-mirror plane</p> $\begin{pmatrix} \pi \\ 0 \\ 0 \end{pmatrix} + P_\phi \quad \begin{array}{l} \varphi_1^e = \pi + \varphi_1 \\ \phi^e = -\phi \\ \varphi_2^e = \varphi_2 \end{array}$	<p>3. two-fold axis</p> $\begin{pmatrix} 0 \\ \pi \\ \pi/2 \end{pmatrix} + L_{\varphi_1}^2 \quad \begin{array}{l} \varphi_1^e = \varphi_1 \\ \phi^e = \pi - \phi \\ \varphi_2^e = \pi/2 - \varphi_2 \end{array}$
<p>Monoclinic</p>	<p>4. two-fold axis</p> $\begin{pmatrix} \pi \\ 0 \\ \pi/2 \end{pmatrix} + L_\phi^2 \quad \begin{array}{l} \varphi_1^e = \pi - \varphi_1 \\ \phi^e = \phi \\ \varphi_2^e = \pi/2 - \varphi_2 \end{array}$
<p>1. translation <math>\Delta\varphi_2 = \pi/2</math></p> $\begin{pmatrix} 0 \\ 0 \\ \pi/2 \end{pmatrix} + E \quad \begin{array}{l} \varphi_1^e = \varphi_1 \\ \phi^e = \phi \\ \varphi_2^e = \varphi_2 + \pi/2 \end{array}$	<p>5. mirror plane</p> $\begin{pmatrix} 0 \\ 0 \\ 0 \end{pmatrix} + P_\phi \quad \begin{array}{l} \varphi_1^e = \varphi_1 \\ \phi^e = -\phi \\ \varphi_2^e = \varphi_2 \end{array}$
<p>2. two-fold screw axis</p> $\begin{pmatrix} \pi \\ \pi \\ \pi/2 \end{pmatrix} + L_{\varphi_1}^2 \quad \begin{array}{l} \varphi_1^e = \pi + \varphi_1 \\ \phi^e = \pi - \phi \\ \varphi_2^e = \pi/2 - \varphi_2 \end{array}$	<p>6. mirror line</p> $\begin{pmatrix} 0 \\ 0 \\ \pi/2 \end{pmatrix} + LM \quad \begin{array}{l} \varphi_1^e = \varphi_1 \\ \phi^e = \pi/2 - \phi \\ \varphi_2^e = 0 \end{array}$
<p>3. two-fold axis</p> $\begin{pmatrix} 0 \\ 0 \\ \pi/2 \end{pmatrix} + L_\phi^2 \quad \begin{array}{l} \varphi_1^e = -\varphi_1 \\ \phi^e = \phi \\ \varphi_2^e = \pi/2 - \varphi_2 \end{array}$	<p>7. mirror point</p> $(\pi/2) + LP \quad \begin{array}{l} \varphi_1^e = \pi/2 - \varphi_1 \\ \phi^e = 0, \pi/2 \\ \varphi_2^e = 0, \pi/2 \end{array}$
<p>4. glide-mirror plane</p> $\begin{pmatrix} \pi \\ 0 \\ 0 \end{pmatrix} + P_\phi \quad \begin{array}{l} \varphi_1^e = \pi + \varphi_1 \\ \phi^e = -\phi \\ \varphi_2^e = \varphi_2 \end{array}$	<p>8. mirror point</p> $(\pi/3) + LP \quad \begin{array}{l} \varphi_1^e = k\pi/3 - \varphi_1 \\ \phi^e = \arccos 1/\sqrt{3} \\ \varphi_2^e = \pi/4 \\ (k = 0, 1, 2 \dots) \end{array}$

Tables for Texture  
Analysis of Cubic  
Crystals, Springer  
Verlag, 1978

Tables for Texture Analysis of Cubic Crystals, Springer Verlag, 1978

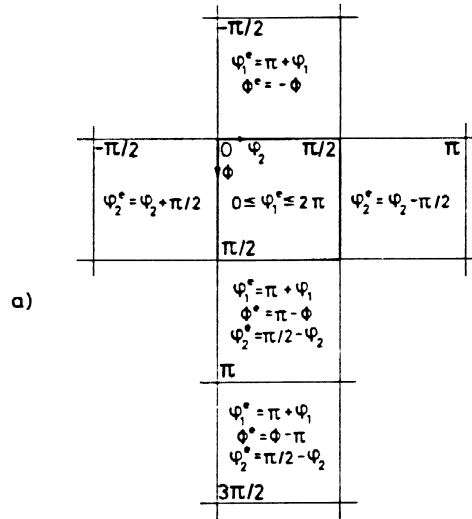

Fig. 21: Transformations leading from different parts of the Euler angle space into the basic range  $H'$  for the triclinic case or into the range  $H''$  for the monoclinic case. In case that two different sets of expressions are listed, the ones in parenthesis are valid for the monoclinic case.

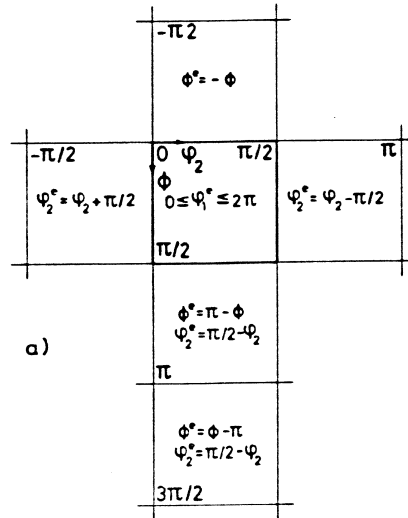
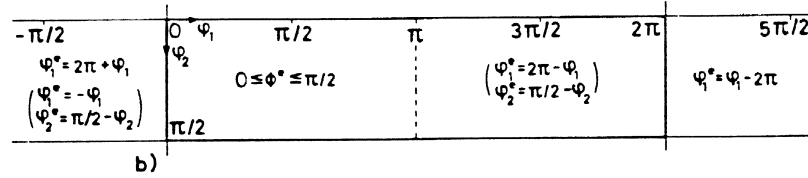
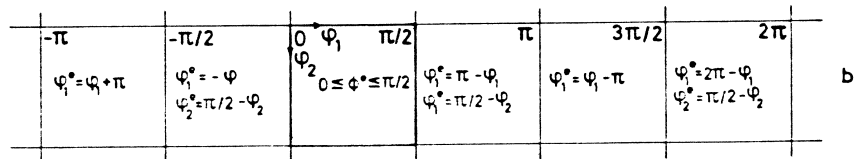

Fig. 22: Transformations leading from different parts of the Euler angle space into the basic range  $H''$  for the orthorhombic case.



## *Determinant of a matrix*

- Multiply each set of three coefficients taken along a diagonal: top left to bottom right are positive, bottom left to top right negative.
- $|a| = a_{11}a_{22}a_{33} + a_{12}a_{23}a_{31} + a_{13}a_{21}a_{32} - a_{13}a_{22}a_{31} - a_{12}a_{21}a_{33} - a_{11}a_{32}a_{23}$   
 $= \varepsilon_{i_1 i_2 \dots i_n} a_{i_1 1} a_{i_2 2} \dots a_{i_n n}$

+ -

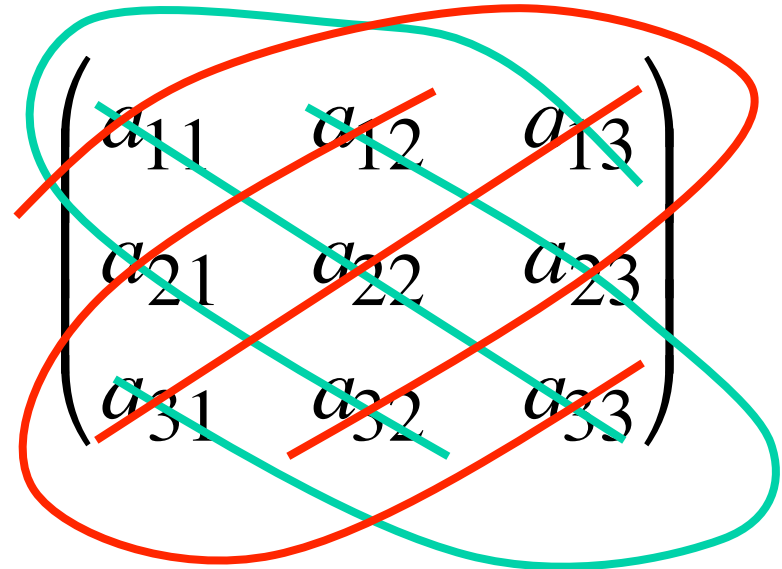

# *Symmetry and Properties*

- For later: when you use a material property (of a single crystal, for example) to connect two physical quantities, then applying symmetry means that the result is unchanged. In this case there *is* an equality. This equality allows us to decrease the number of independent coefficients required to describe an anisotropic property (Nye).

# Anisotropy

- Given an orientation distribution,  $f(g)$ , one can write the following for any tensor property or quantity,  $\mathbf{t}$ , where the range of integration is over the fundamental zone of physically distinguishable orientations,  $SO(3)/G$ .
- “ $SO(3)$ ” means all possible proper rotations in 3D space (but not reflections); “ $G$ ” means the set (group) of symmetry operators, e.g. (432) for the proper rotations in the cubic system;  $SO(3)/G$  means the space of rotations divided by the symmetry group.

$$\langle \mathbf{t} \rangle = \int_{SO(3)/G} \mathbf{t}(g) f(g) dg$$



# Homework

- This describes the part of the homework (Hwk 3) that deals with learning how to apply symmetry operators to components and find all the symmetrically related positions in Euler space.
  - A. Write the symmetry operators for the cubic crystal symmetry (point group 432) as matrices into a file (or as an array in a Matlab script). It is sensible to put three numbers on a line, so that the appearance of the numbers is similar to the way in which a 3x3 matrix is written in a book. You can simply copy what was given in the slides (taken from the Kocks book). Matlab examples, with the ID of the operator written as the 3<sup>rd</sup> index:  $e(:, :, 1) = [1 \ 0 \ 0; 0 \ 1 \ 0; 0 \ 0 \ 1]$ ;  $e(:, :, 2) = [1 \ 0 \ 0; 0 \ -1 \ 0; 0 \ 0 \ -1]$ ; etc.
  - [Alternatively, you can work out what each matrix is based on the actual symmetry operator. This is more work but will show you more of what is behind them.]
  - B. Write the symmetry operators for the orthorhombic sample symmetry (point group 222) as matrices into a separate file (or as an array in a Matlab script).
  - C. Write a computer code that reads in the two sets of symmetry operators (cubic crystal, asks for an orientation specified as (six) Miller indices, (h,k,l)[u,v,w], and calculates each new orientation, which should be written out as Euler angles (meaning, convert the result, which is a matrix, back to Euler angles). Note that the identity operator is always include as the first symmetry operator. So, even if you apply no symmetry, in terms of loops in your program, you go at least once through each loop where the first time through is applying the identity operator (ones on the diagonal, zeros elsewhere).
  - D. List all the equivalent points for  $\{123\}\langle 63\text{-}4\rangle$  for triclinic (meaning, no sample symmetry). In each listing, identify the points that fall into the 90x90x90 region typically used for plotting.
  - E. List all the equivalent points for  $\{123\}\langle 63\text{-}4\rangle$  for monoclinic (use only the ND-diad operator, i.e. 180° about the sample z-axis). In each listing, identify the points that fall into the 90x90x90 region typically used for plotting.
  - F. List all the equivalent points for  $\{123\}\langle 63\text{-}4\rangle$  for orthorhombic sample symmetries (use all 3 diads in addition to the identity). In each listing, identify the points that fall into the 90x90x90 region typically used for plotting.
  - G. Repeat 3f above for the Copper component, (112)[11-1].
  - H. How many different points do you find for each of the three sample symmetries?
  - I. How many points fall within the 90x90x90 region that we typically use for plotting orientation distributions?
- Students may code the problem in any convenient language (Excel, C++, Pascal....) but are strongly encouraged to do the exercises in MATLAB: be very careful of the order in which you apply the symmetry operators!