

# Analysis of EBSD Data

27-750

Texture, Microstructure & Anisotropy

B. El-Dasher\*, A.D. Rollett, M.H. Alvi†,  
G.S. Rohrer, P.N. Kalu<sup>1</sup>, T. Bennett<sup>2</sup>,  
N. Bozzolo<sup>3</sup> and F. Wagner<sup>4</sup>

\*formerly at Lawrence Livermore Natl. Lab.; †Intel; <sup>1</sup>FAMU/FSU;  
<sup>2</sup>Jamaica; <sup>3</sup>CEMEF, Sophia Antipolis, France; <sup>4</sup>LEM<sup>3</sup>, Metz, France;

*Last revised: 30<sup>th</sup> March '16*

# Electron Back-Scatter Diffraction (EBSD/OIM)

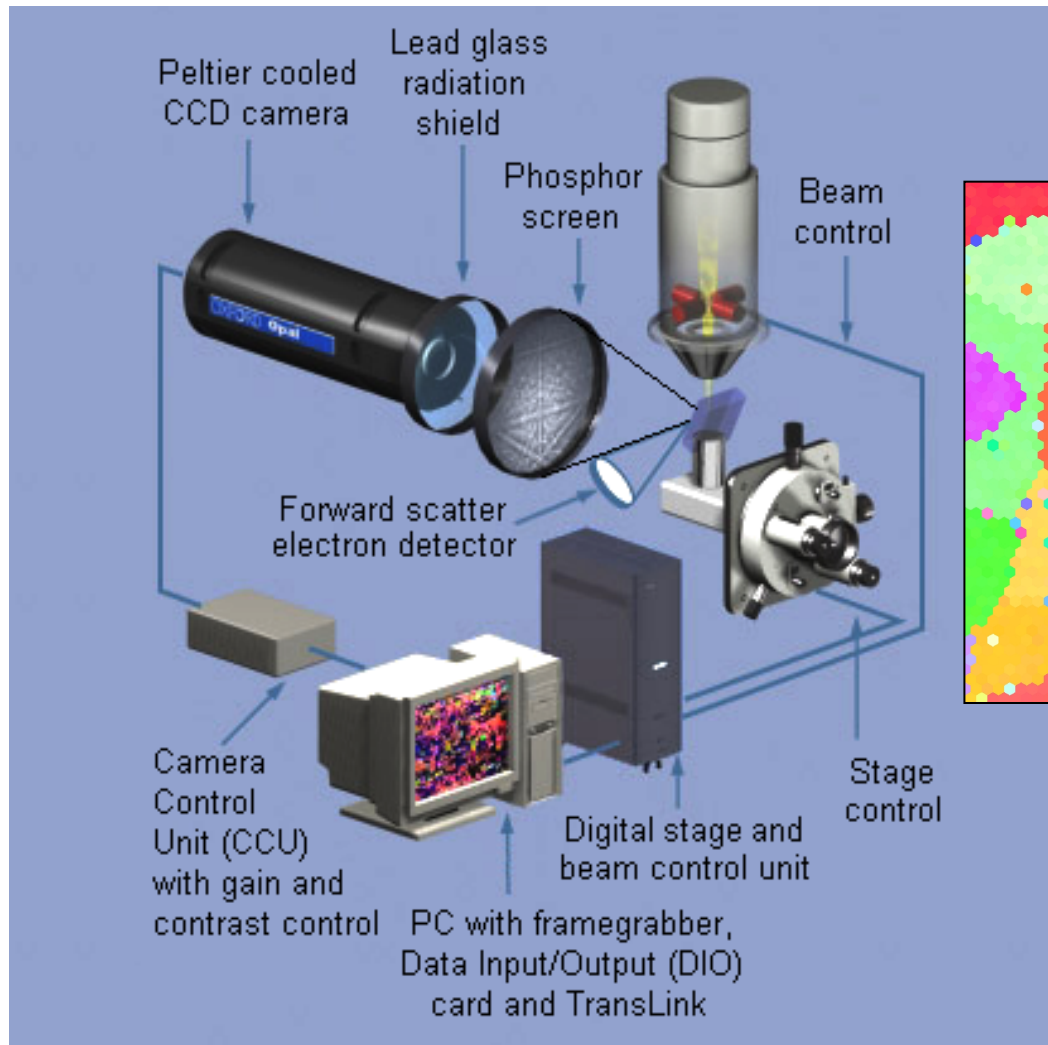

Schematic diagram of a typical EBSD system (Oxford INCA)

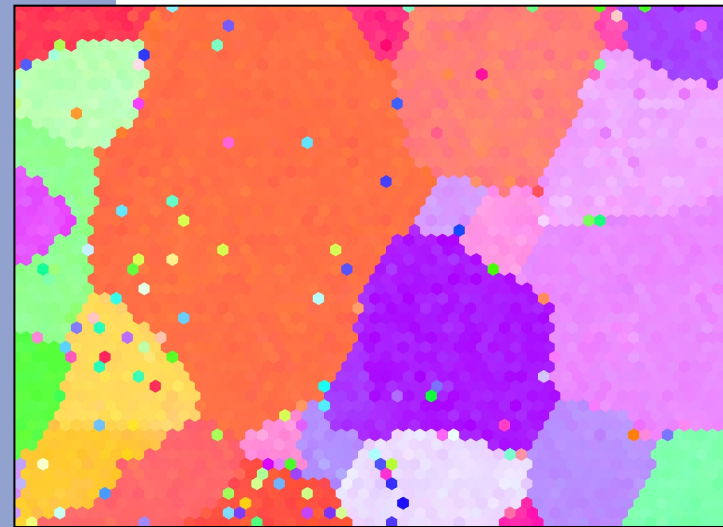

Provides (2D regular grid) maps of crystal orientation from polished cross-sections

# Overview

---

- Understanding the program:
    - Important menus
    - Definition of Grains in OIM
    - Partitioning datasets
  - Cleaning up the data:
    - Types
    - Examples of Neighbor correlation
    - *Importance of reporting clean-up in reports*
  - Orientation:
    - System Definition
    - Distribution Functions (ODFs)
    - Plotting ODFs
-

# Overview

---

- Misorientation:
    - Definitions - Orientation vs. Misorientation
    - Distribution Functions (MDFs)
    - Plotting MDFs
  - Other tools:
    - Plotting Distributions
    - Interactive tools
  - Frames of Reference:
    - Spatial versus Euler frames
    - Different suppliers of software
    - Issues with Hexagonal materials
  - Important: the menus change as the software packages are updated. Although this lecture is illustrated from (older versions of) the TSL software, similar functions are available in other EBSD analysis software. Mtex also provides a number of the analysis functions.
-

# Questions & Answers

---

- How are Orientation Distributions computed?
    - The discrete orientations provide the input data to which the coefficients of the generalized spherical harmonic functions are fitted.
  - What is the difference between a discrete plot and a contour plot and when should I use them?
    - The discrete plots provide individual points in pole figures, inverse pole figures, ODs etc. Contour plots are always based on the fitted generalized spherical harmonic functions.
  - What is meant by the various different measures of orientation spread within a grain, and what are they useful for?
    - The names given to the functions vary across the packages. There is a pixel-based measure that computes the average of the misorientation between a given point/pixel and its first nearest neighbor points (generally, 8 NN in a square lattice); there is also an average over all points in a given grain (e.g. Grain Average Misorientation). This is sensitive to only local orientation gradients. There is also a pixel-based measure that gives the misorientation between the given point and the average orientation for the grain; likewise there is an average quantity for the whole grain. This pair of measures are sensitive to long range orientation gradients (found, e.g., in shear bands, kink bands etc.).
-

# Questions & Answers

---

- Why do I have to worry about reference frames?
    - Orientations are given in reference to a frame that is different from the frame in which the coordinates of the image; see the notes for details. Different softwares have different alignments, and hexagonal materials are a particular problem because of different conventions for the alignment of the orthonormal frame used for calculation versus the crystallographic frame of reference.
  - What is “clean-up”?
    - “Clean-up” is a generic term for the various steps used to remove unreliable or non-indexed points from the map and replace them with (in general) more reliable orientations from neighboring pixels. Generally speaking, the methods are analogous to “erosion” and “dilation” used in image processing.
  - How is the grain structure determined (slide 9)?
    - The procedure that is typically used is known as a “burn algorithm” in percolation analysis. One starts at an arbitrary pixel location and uses it as the starting point of a grain; add any nearest neighbor pixel to the grain that has a misorientation with the first point less than some user-chosen threshold. Repeat until no more points can be added according to the threshold. The largest threshold typically used is  $15^\circ$ , i.e. the limit for low-angle boundaries in cubic materials.
-

# Navigating the menus

- There are two menus that access virtually everything:

Check the scan stats

Rotate the *orientations* of each point about *sample frame*

Cut out scan sections

Check the partition stats & definition

Change the partition properties:  
- Decide which points to include  
- Define a “grain”

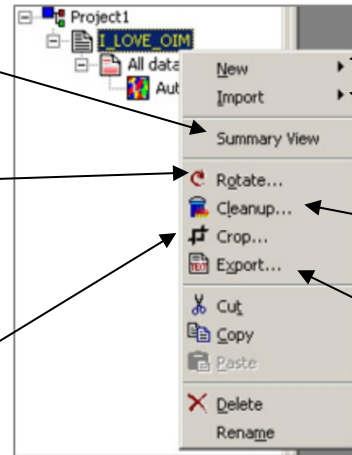

Creates new partitions

Imports data as partitions

Access to routines that cleanup the dataset

Use this to export text .ang files

Access to menu for:  
- Maps  
- Texture calculation  
- Texture plots

Export grain ID data associated with each point

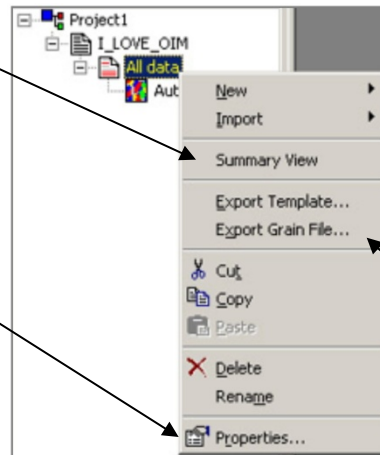

# Grain Definitions

---

- OIM defines a set of points to constitute a grain if:

- A path exists between any two points (in the set) such that it does not traverse a misorientation angle more than a specified tolerance

- The number of *points* is greater than a specified number

Points with a CI less than specified are excluded from *statistics*

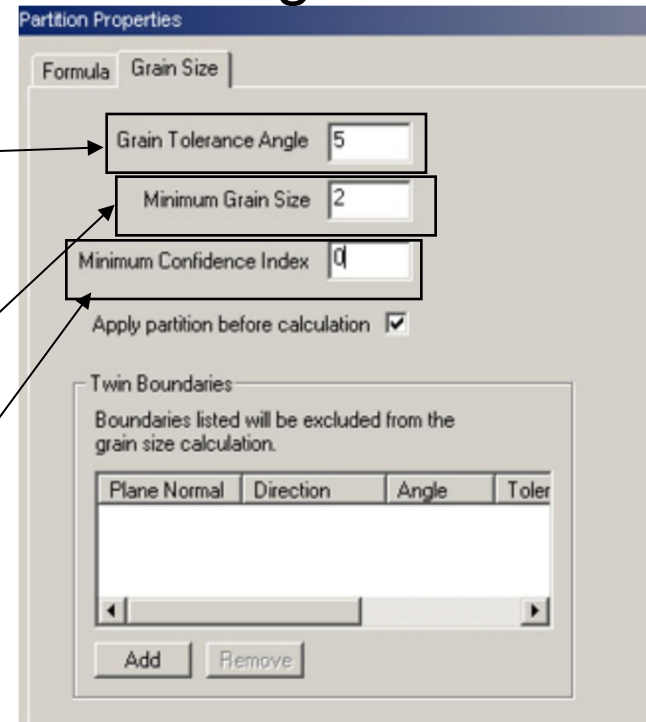

**Note:** Points that are excluded are given a grain ID of 0 (zero) in exported files

---



# Grain Definitions

---

Examples of definitions

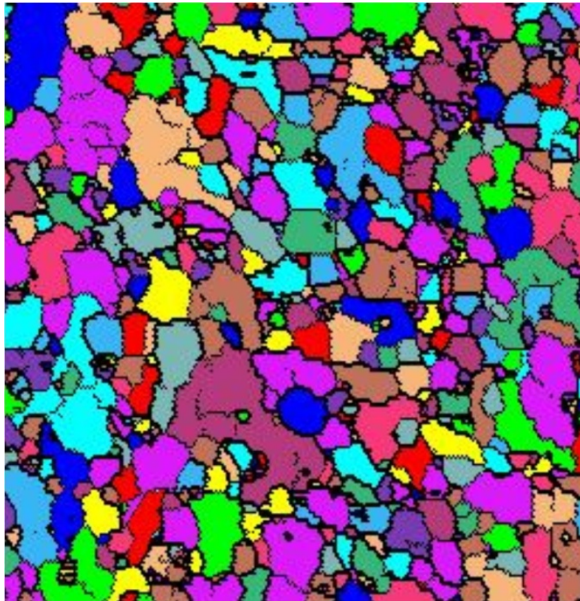

3 degrees

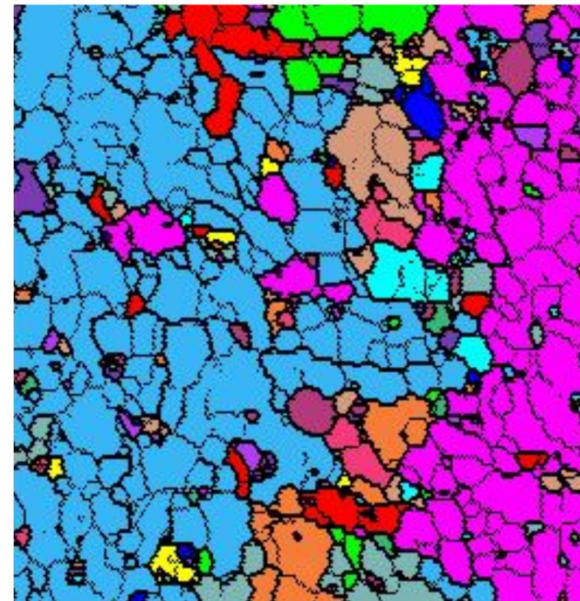

15 degrees

Note that each color represents 1 grain

---

# Partitioning Datasets

- Choose which points to include in analysis by setting up selection formula

Use to select by individual point

The image displays two software windows used for data partitioning. The 'Crystal Direction' window on the left is titled 'Crystal Direction' and has tabs for 'Direction' and 'Deviation'. The 'Phase' is set to 'Aluminum'. Below this, there are input fields for u, v, w, RD, TD, and ND. The values are: u=0, v=0, w=1, RD=0, TD=0, ND=1. A 3D diagram shows a cylindrical sample with a grid on its end face, and a rectangular sample with a grid on its top surface. Red arrows indicate the ND (Normal Direction), RD (Rolling Direction), and TD (Transverse Direction) axes. An electron beam (e-) is shown incident on the top surface. The 'Formula' window on the right has tabs for 'Formula' and 'Grain Size'. It is divided into 'Point Properties' and 'Grain Properties'. The 'Point Properties' section includes buttons for Confidence Index, Image Quality, Video Signal, Phase, Crystal Direction, Crystal Orientation, Taylor Factor, and Schmid Factor. The 'Grain Properties' section includes buttons for Size, Aspect Ratio, Rotation Angle, Orientation Spread, Average IQ, Average CI, and Average VS. Below these sections are logical operators: { }, <, >, =, <=, >=, !=, NOT, AND, OR, and Undo. A large empty text area is provided for entering a selection formula.

# Data Cleanup

## Neighbor Orientation Correlation

- Performed on points with  $C$  less than a given threshold
- A point becomes part of the neighbor with highest  $C$  is assigned to those points
- Takes when majority of points are high and only a few bad points exist

- Use to remove bad points due to pits or at G.Bs

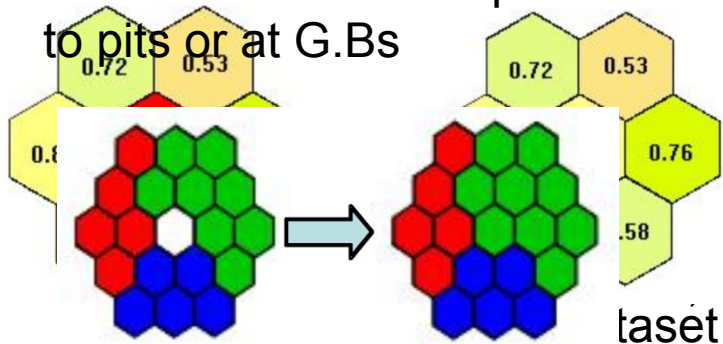

directly to file

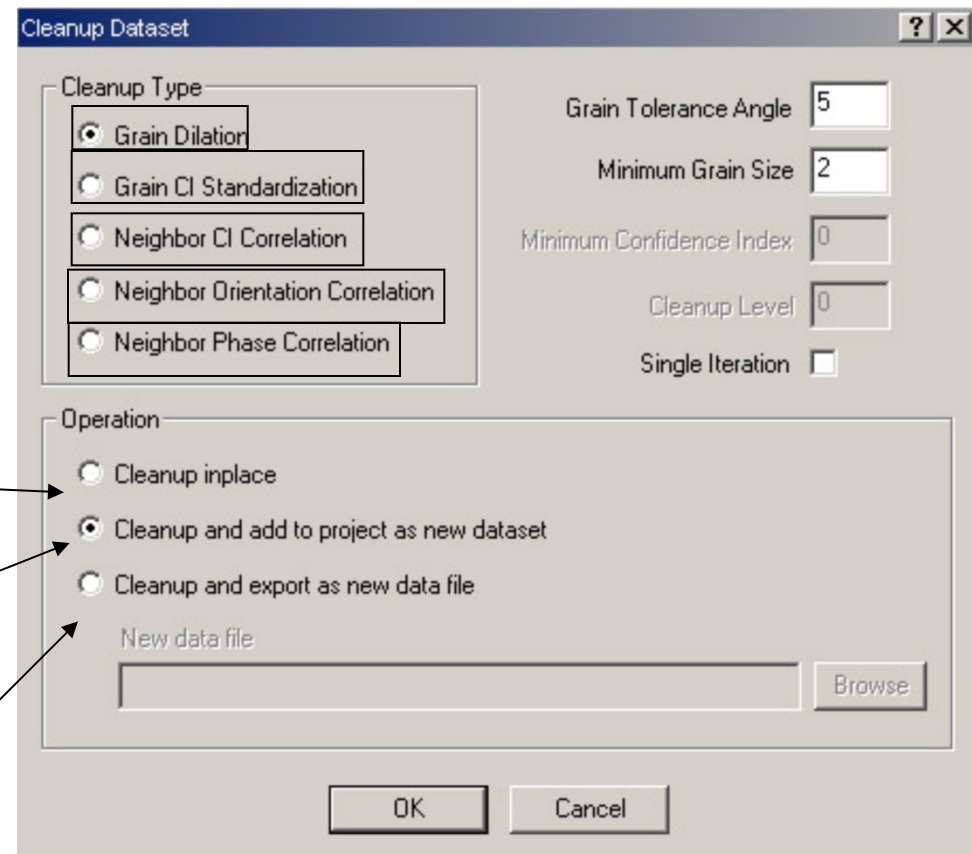

# Neighbor Correlation Example

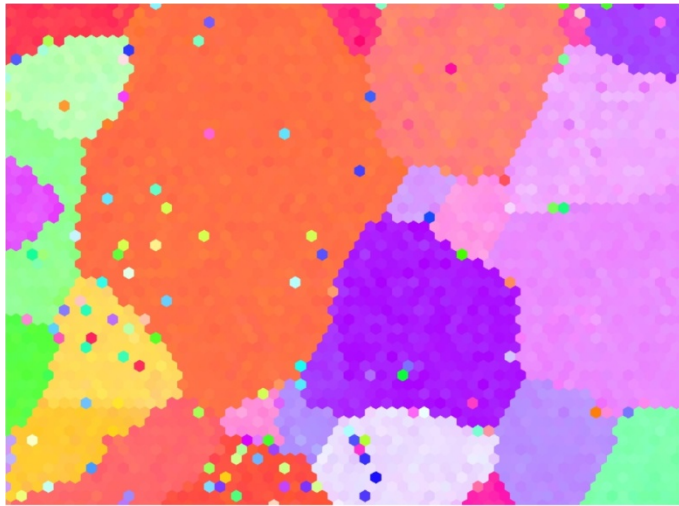

No Cleanup

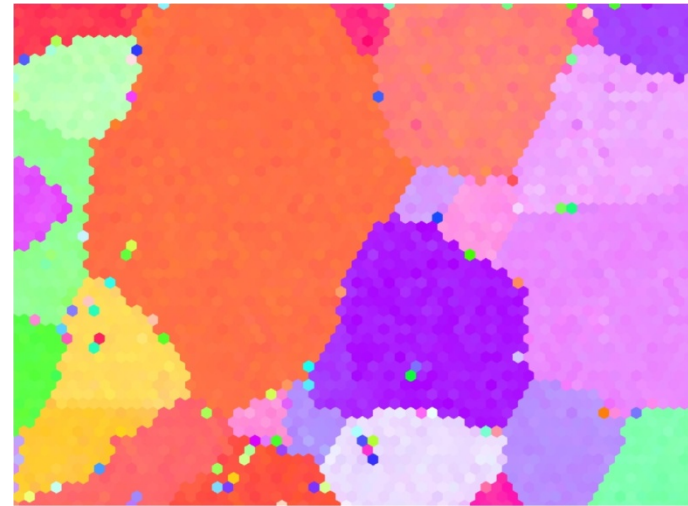

Level 0



Level 3

Note that Higher cleanup levels are iterative (i.e. Level 3= Levels 0,1,2,3)

# Definition of Orientation

---

- By definition an orientation is always relative. The OIM uses the sample surface to define the orthogonal reference frame.

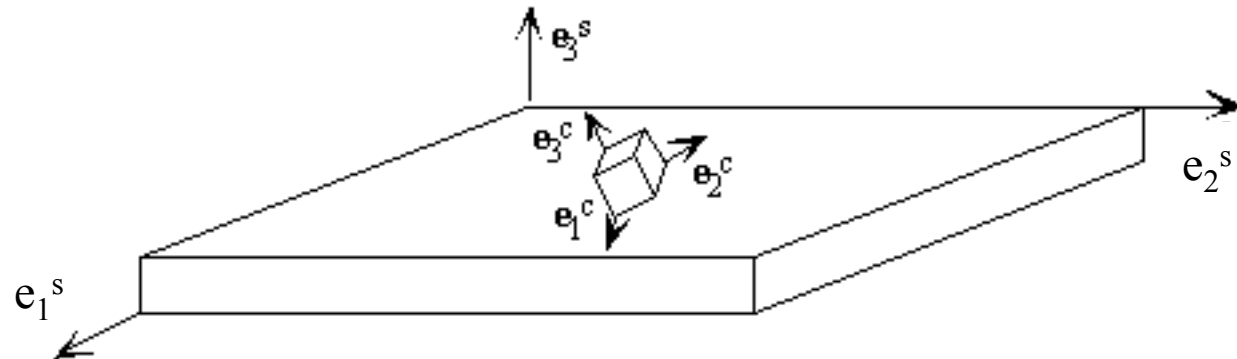

- Quantities are transformed **from** sample frame to **crystal** frame

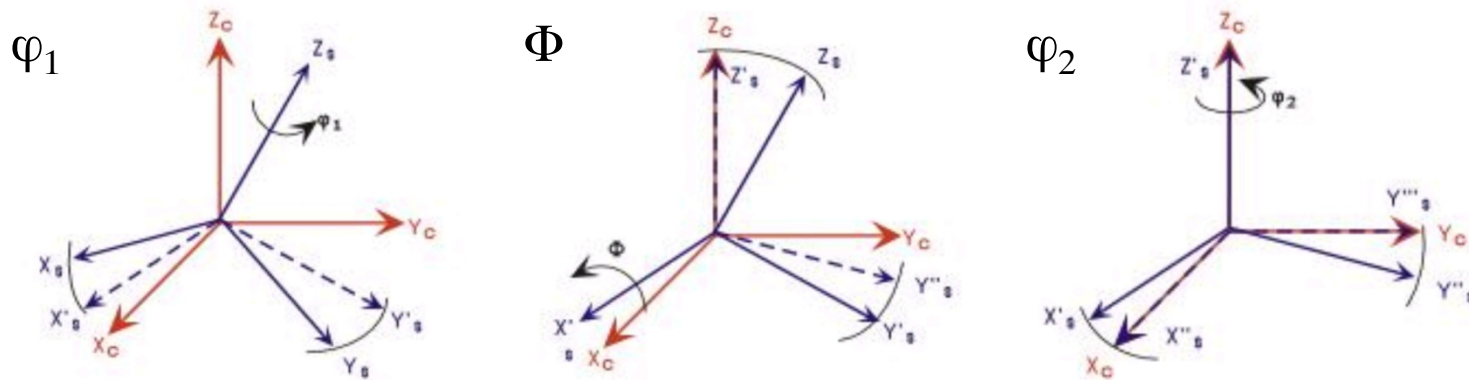

---

**NB: a more comprehensive discussion of reference frames is given later**

# Reference Frames

---

- This next set of slides is devoted to explaining, as best we can, how to relate features observed in EBSD images/maps to the Euler angles.
  - In general, the Euler frame is not aligned with the x-y axes used to measure locations in the maps.
  - The TSL (OIM™) and Channel (HKL) softwares both rotate the image 180° relative to the original physical sample.
  - Both TSL (OIM™) and Channel (HKL) softwares use different reference frames for measuring spatial location versus the the Euler angles, which is, of course, extremely confusing.
-

# TSL / OIM Reference Frames

$Z_{\text{spatial}}$  points *in* to the plane  
 $Z_{\text{Euler}}$  points *out* of the plane

The purple line indicates a direction, associated with, say, a scratch, or trace of a grain boundary on the specimen.

## Physical specimen:

Mounted in the SEM, the tilt axis is parallel to " $X_{\text{spatial}}$ "

$TD = y_{\text{Euler}} = 010_{\text{sample}}$   $X_{\text{spatial}}$

$RD = x_{\text{Euler}} = 100_{\text{sample}}$

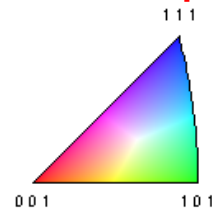
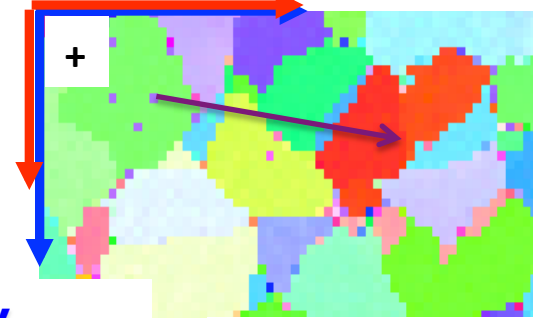

**Image:**  
 Note the 180° rotation.

## Sample Reference Frame for Orientations/Euler Angles

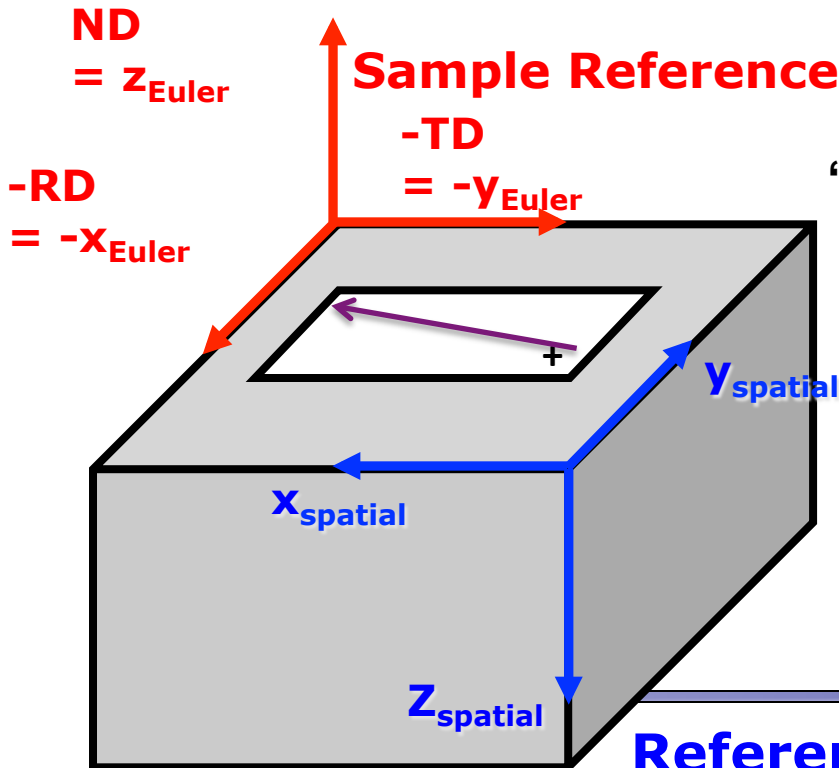

"+" denotes the Origin

## Crystal Reference Frame:

Remember that, to obtain directions and tensor quantities in the crystal frame for each grain (starting from coordinates expressed in the Euler frame), one must use the Euler angles to obtain a transformation matrix (or equivalent).

## Reference Frame for Spatial Coordinates

# TSL / OIM Reference Frames for Images

Conversion from spatial to Euler and vice versa (TSL only)

From Herb Miller's notes:

The axes for the TSL Euler frame **are** consistent with the RD-TD-ND system in the TSL Technical Manual, but only with respect to maps/images, not the physical specimens.

The axes for the HKL system **are** consistent with the information provided by users in Metz. Here, x is in common, but the two y-axes point in opposite directions.

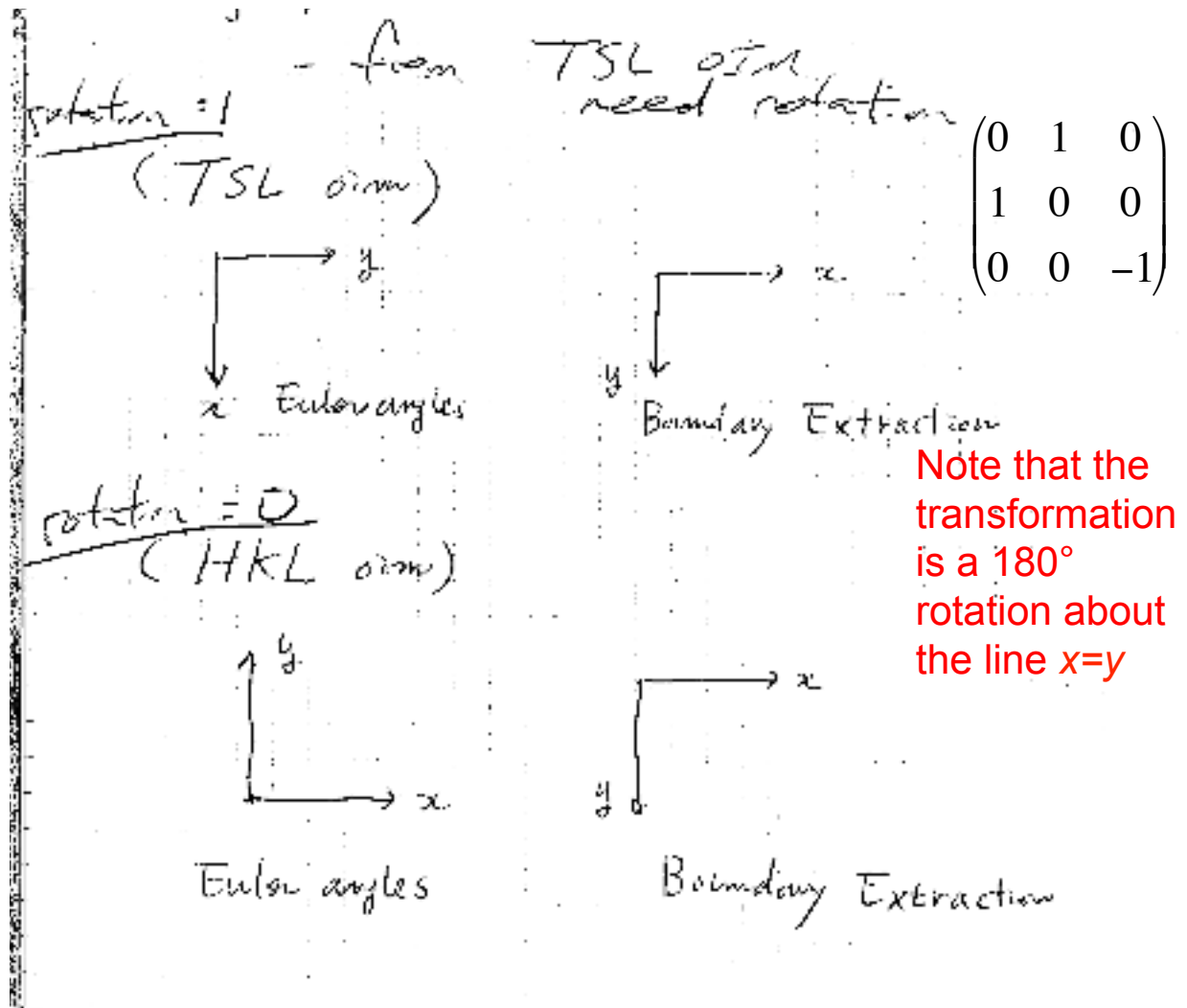

Notes: the image, as presented by the TSL software, has the vertical axis inverted in relation to the physical sample, i.e. a 180° rotation.



## TSL / OIM Reference Frames:

### Coordinates in **Physical Frame**, Conversion to **Image**

- The previous slides make the point that a transformation is required to align spatial coordinates with the Euler frame.
- However, there is also a  $180^\circ$  rotation between the physical specimen and the image. Therefore to align physical markings on a specimen with traces and crystals in an image, it is necessary to take either the physical data and rotate it by  $180^\circ$ , or to rotate the crystallographic information.

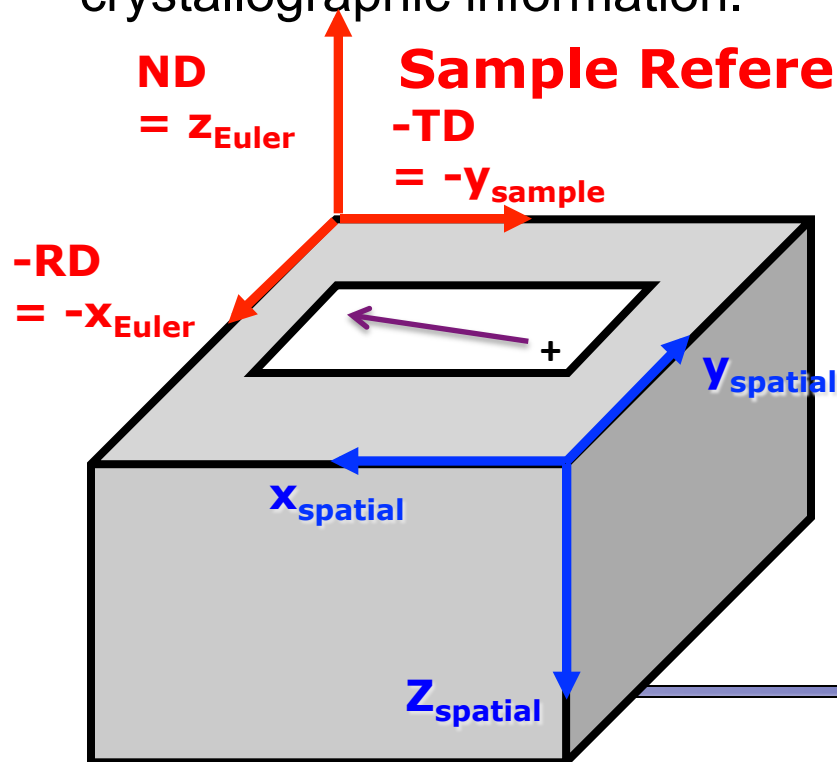

- How to measure lines etc. on a physical specimen?
- Answer: use the spatial frame as shown on the diagram to the left (which is NOT the normal, mathematical arrangement of axes) and your measured coordinates will be correct in the images, provided you plot them according to the IMAGE spatial frame. The purple line, for example, will appear on the image (e.g. an IPF map) as turned by  $180^\circ$  in the x-y plane.

# Cartesian Reference Frame for Physical Measurement

---

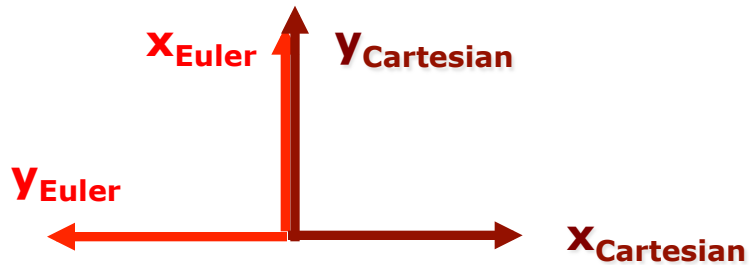

$$\begin{pmatrix} 0 & 1 & 0 \\ -1 & 0 & 0 \\ 0 & 0 & 1 \end{pmatrix}$$

- How to measure lines etc. on a physical specimen using the standard **Cartesian frame** with x pointing right, and y pointing up?
- Answer: use the **Cartesian frame** as shown on the diagram to the left (which IS the normal, mathematical arrangement of axes and is NOT the **frame used for point coordinates** that you find in a .ANG file). Apply the transformation of axes (passive rotation) as specified by the transformation matrix shown and then your measured coordinates will be in the same frame as your Euler angles. This transformation is a +90° rotation about  $z_{sample}$ . In this case, the z-axis points out of the plane of the page.

# TSL / OIM Reference Frames: Labels in the TSL system

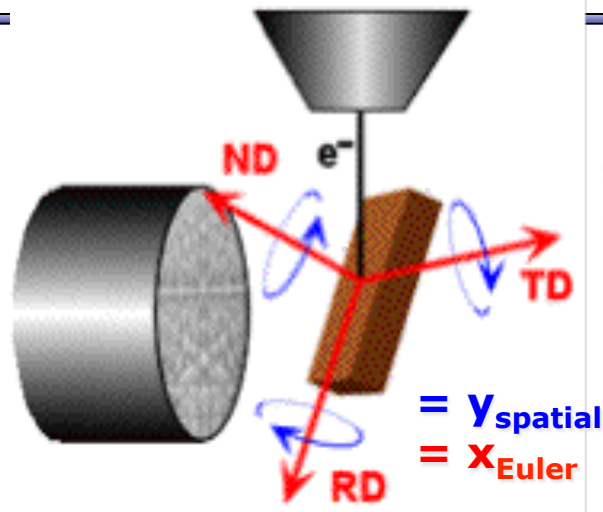

The diagram is reproduced from the TSL Technical Manual (v5 and older); the designation of RD, TD and ND is only correct for Euler angles in reference to the plotted maps/images, *not* the physical specimen

- What do the labels “RD”, “TD” and “ND” mean in the TSL literature?
- The labels should be understood to mean that RD is the x-axis, TD is the y-axis and ND the z-axis, all for Euler angles (but *not* spatial coordinates).
- The labels on the Pole Figures are consistent with the maps/images (but NOT the physical specimen).
- The labels on the diagram are consistent with the maps/images, but NOT the physical specimen, as drawn.
- The frame in which the spatial coordinates are specified in the datasets is different from the Euler frame (RD-TD-ND) – see the preceding diagrams for information and for how to transform your spatial coordinates into the same frame as the Euler angles, using a  $180^\circ$  rotation about the line  $x=y$ .

# TSL versus HKL Reference Frames

- The two spatial frames are the same, exactly as noted by Changsoo Kim and Herb Miller previously. The figures show *images* (as opposed to physical specimen).
- The Euler angle references frames differ by a rotation of  $+90^\circ$  (add  $90^\circ$  to the first Euler angle) going from the TSL to the HKL frames (in terms of an axis transformation, or passive rotation). Vice versa, to pass from the HKL to the TSL frame, one needs a rotation of  $-90^\circ$  (subtract  $90^\circ$  from the first Euler angle).
- The position of the “sample” axes is critical. The names “RD” and “TD” do not necessarily correspond to the physical “rolling direction” and “transverse direction” because these depend on how the sample was mounted in the microscope.

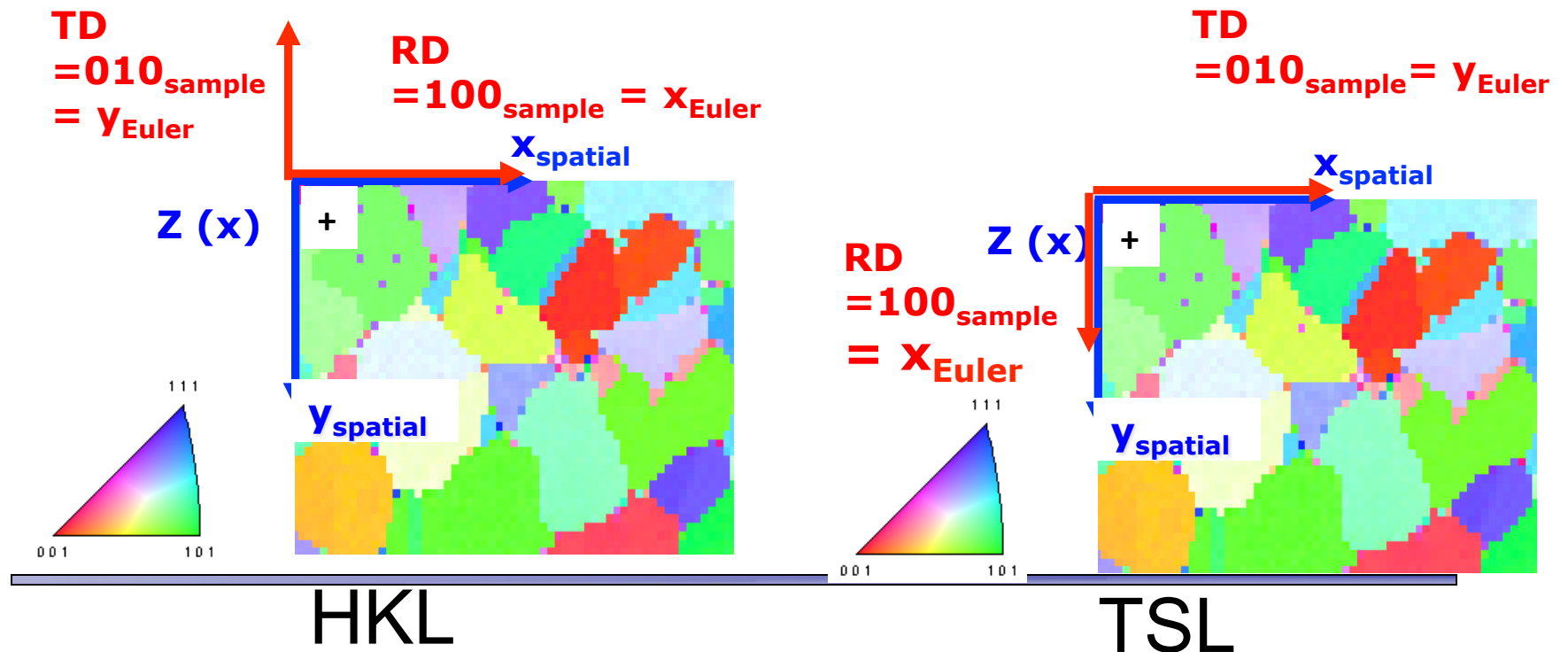

# Test of Euler Angle Reference Frames

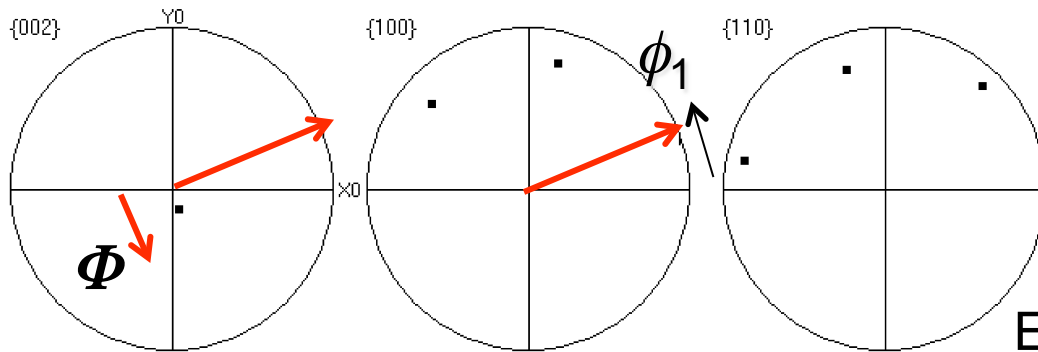

Pole Figures  
 [HEX\_test\_map\_HKL\_In  
 Zirc-alloy4 (6/mmm)  
 Complete data set  
 16 data points  
 Stereographic projection  
 Upper hemispheres

Hexagonal crystal symmetry (no sample symmetry)

Euler angles: 17.2°, 14.3°, 0.57°

## HKL

A simple test of the frames used for the Euler angles is to have the software plot pole figures for a single orientation with small positive values of the 3 angles. This reveals the position of the crystal x-axis via the sense of rotation imposed by the second Euler angle,  $\phi_1$ .

Clearly, one has to add 90° to  $\phi_1$  to pass from HKL coordinates to TSL coordinates. Note that the CMU TSL is using the x//1120 convention (“X convention”), whereas the Metz Channel/HKL software is using the y//1120 convention (“Y convention”).

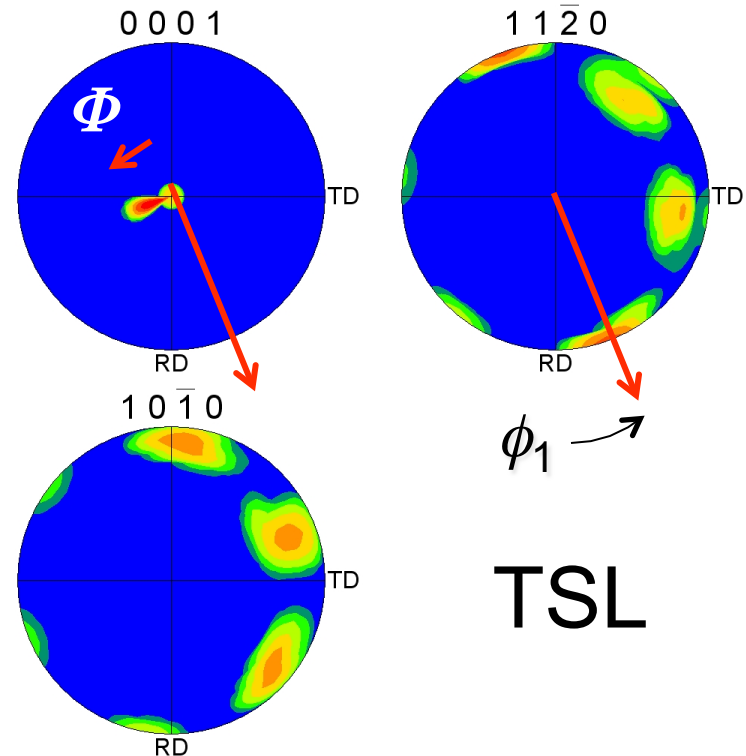

## TSL

# The Axis Alignment Issue for Hexagonal

---

- The issue with hexagonal materials is the alignment of the Cartesian coordinate system used for calculations with the crystal coordinate system (the Bravais lattice).
- In one convention (e.g. popLA, TSL), the x-axis, i.e.  $[1,0,0]$ , is aligned with the crystal  $a_1$  axis, i.e. the  $[2,-1,-1,0]$  direction. In this case, the y-axis is aligned with the  $[0,1,-1,0]$  direction.
- In the other convention, (e.g. HKL, Univ. Metz software), the x-axis, i.e.  $[1,0,0]$ , is aligned with the crystal  $[1,0,-1,0]$  direction. In this case, the y-axis is aligned with the  $[-1,2,-1,0]$  direction.
- See next page for diagrams.
- This is important because texture analysis can lead to an ambiguity as to the alignment of  $[2,-1,-1,0]$  versus  $[1,0,-1,0]$ , with apparent  $30^\circ$  shifts in the data.
- Caution: it appears that the axis alignment is a choice that must be made when installing TSL software so determination of which convention is in use must be made on a case-by-case basis. It is fixed to the y-convention in the HKL software.
- The main clue that something is wrong in a conversion is that either the 2110 & 1010 pole figures are transposed, or that a peak in the inverse pole figure that should be present at 2110 has shifted over to 1010.

# Hexagonal Materials: Diagram of Axes

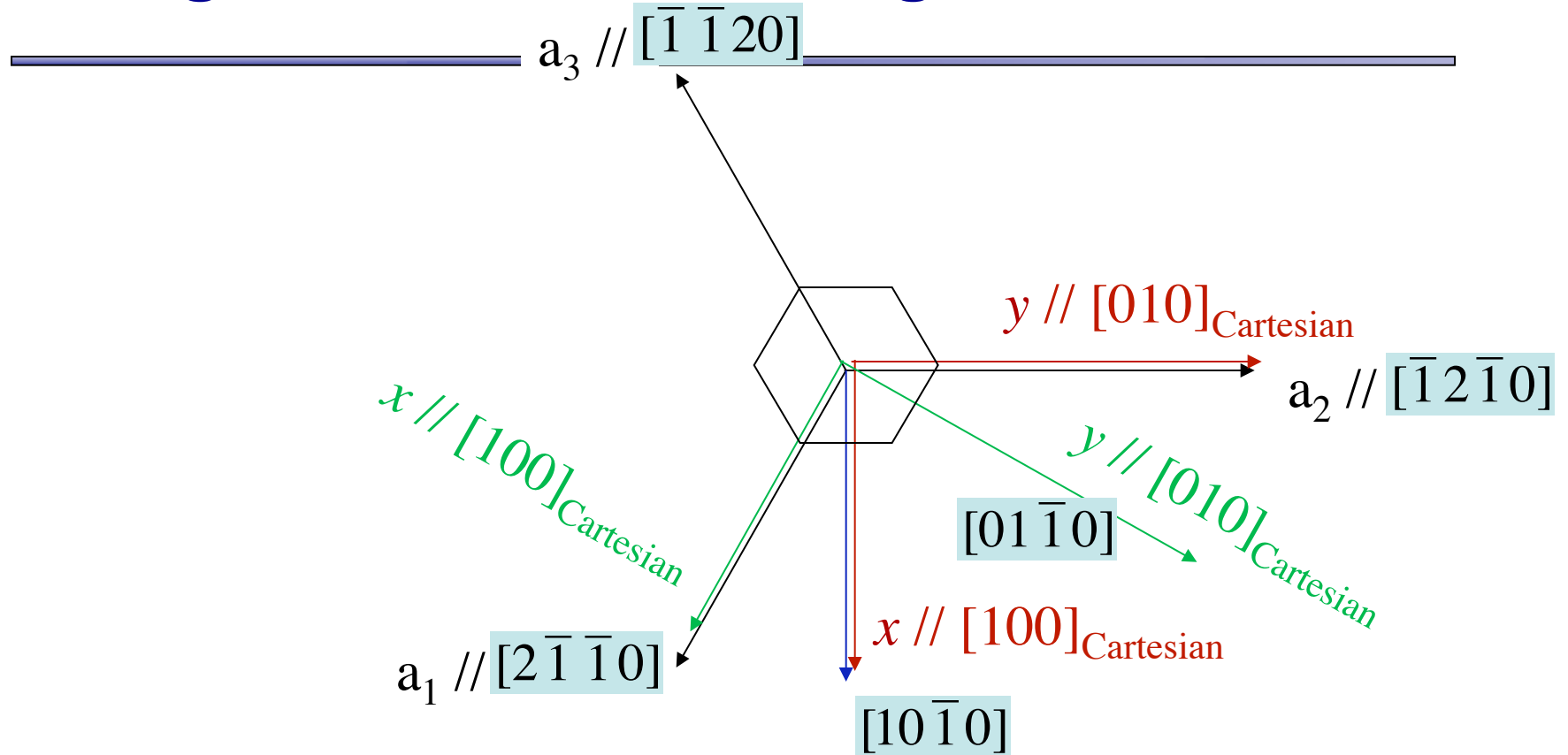

[uvw] Direction	Cartesian/ x-convention	Cartesian/ y-convention
$[2\bar{1}\bar{1}0]$	+1, 0, 0	$+\sqrt{3}$ , -1, 0
$[\bar{1}2\bar{1}0]$	-1, $+\sqrt{3}$ , 0	0, 1, 0
$[\bar{1}\bar{1}20]$	-1, $-\sqrt{3}$ , 0	$-\sqrt{3}$ , -1, 0
$[10\bar{1}0]$	$+\sqrt{3}$ , +1, 0	1, 0, 0
$[01\bar{1}0]$	0, +1, 0	+1, $+\sqrt{3}$ , 0
$[1\bar{1}00]$	$+\sqrt{3}$ , -1, 0	+1, $-\sqrt{3}$ , 0

# Euler Angles

---

- To add to the confusion, all of the different Euler angle conventions can, and are used for hexagonal materials.
  - Recall that Bunge Euler angles make the second rotation about the x-axis, whereas Roe, Matthies and Kocks angles rotate about the y-axis.
  - Generally speaking there is no problem provided that one stays within a single software analysis system for which the indexing is self-consistent. There are, however, known issues with calculation of inverse pole figures in the popLA package.
-



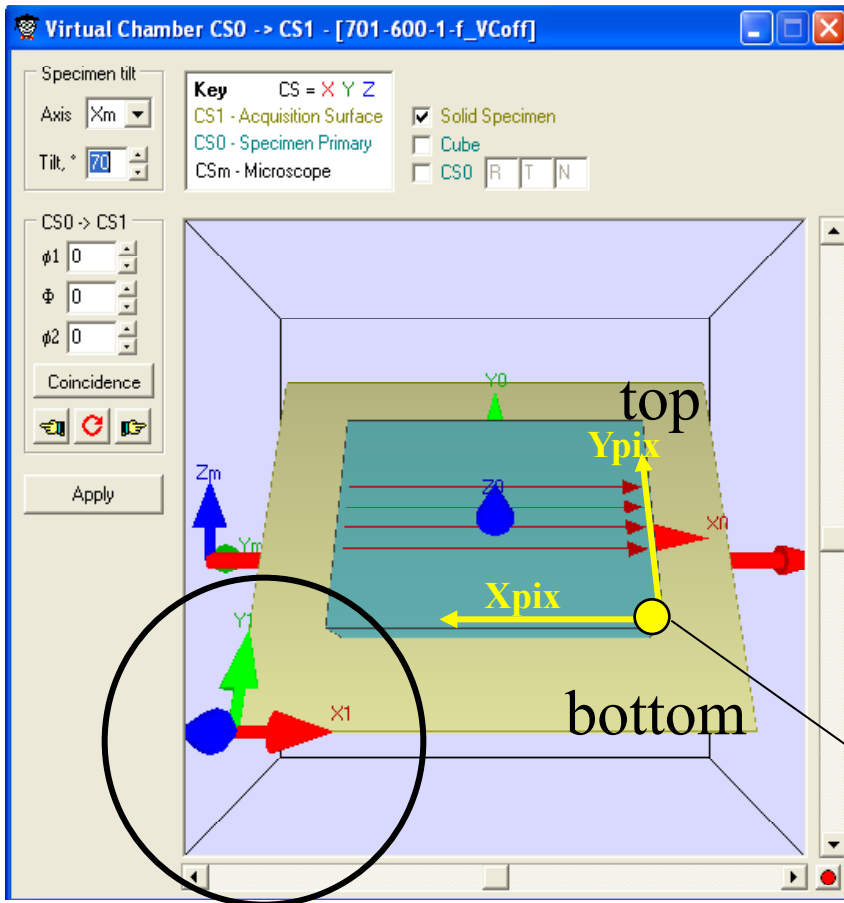

Euler angle reference frame

section reference

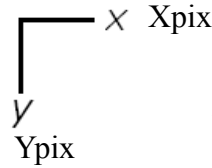

# HKL frames

possible Euler angle reference frames

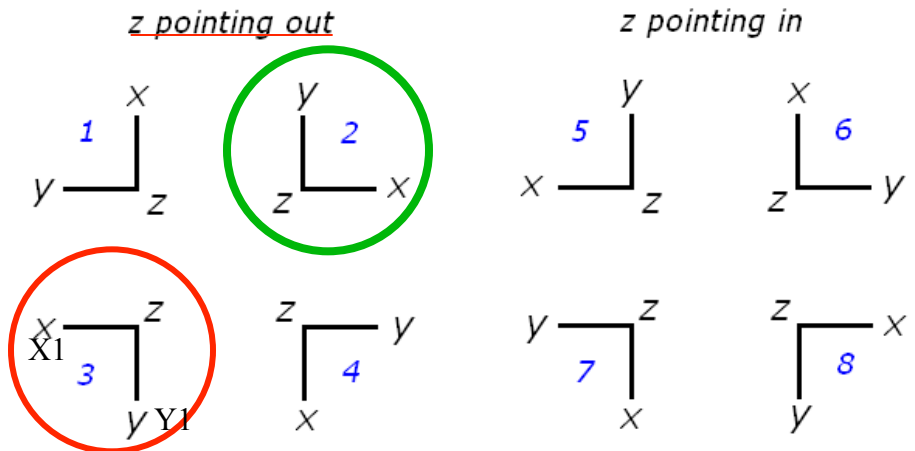

CS1 = raw data format

first acquired pixel  
(Xpix=1, Ypix=1)

CS0 is modified by the user to align axes however they please. The CTF format always exports in CS0 arrangement.

"Virtual chamber" of HKL software, which is used to define the specimen orientation in the microscope chamber

(= how to align frame\_0 with frame\_1); picture is drawn as if the observer was the camera. Note that the maps are turned by 180° with respect to this picture.

- original Euler angles are given in frame\_1 (also called CS1)

The ctf format is designed to export Euler angle into frame\_0 (CS0), which is correct, provided that the specimen orientation is correctly defined.

# HKL software

## keeping CS0 (sample frame) aligned with CS1(microscope frame)

- relying on what the virtual chamber is showing :

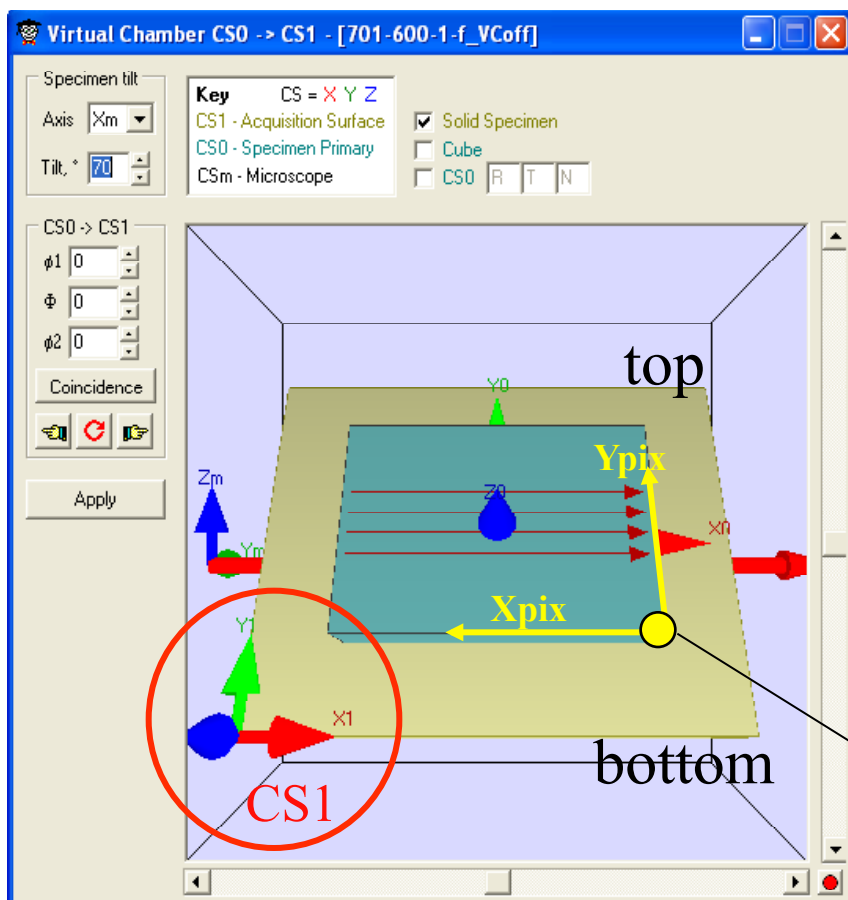

section reference

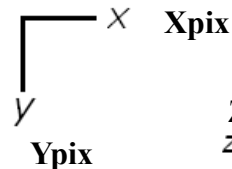

possible Euler angle reference frames

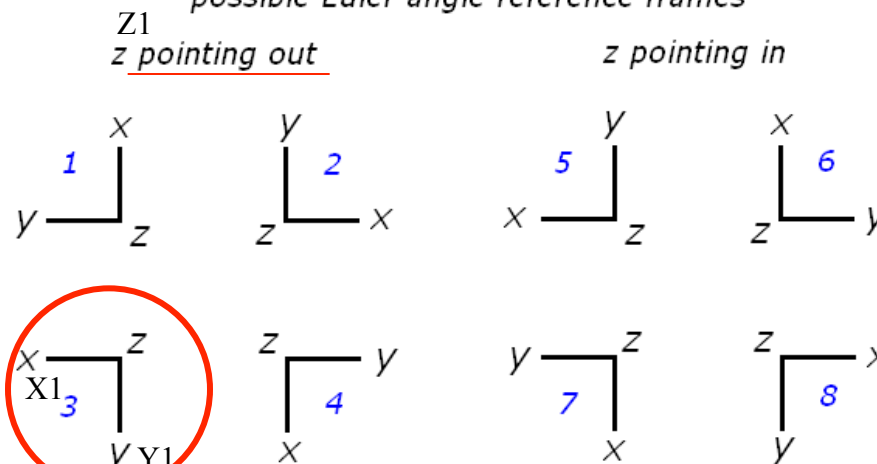

CS1 as shown in the virtual chamber

first acquired pixel ( $X_{\text{spatial}}=1, Y_{\text{spatial}}=1$ )  
= top left pixel of the resulting map

- but this alignment is not consistent with the axes of the PF plots...  
or with previous experience with data sets from the HKL software

# Beta-transformed Ti (from Nathalie Gey, LETAM – now LEM3)

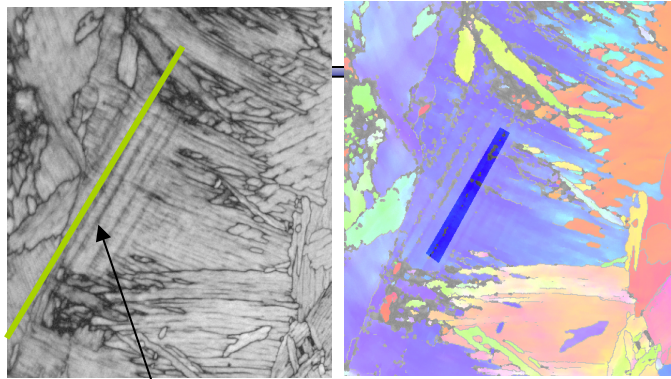

Traces of {10-10} planes

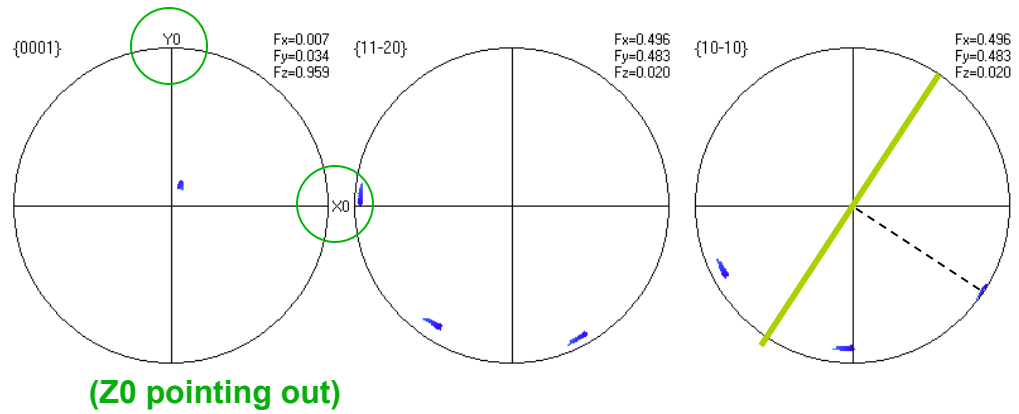

Pole Figures
[HF1_P28cut1_FA.cpr]
Ti-Hex (6/mmm)
Subset3
3608 data points
Equal Area projection
Upper hemispheres

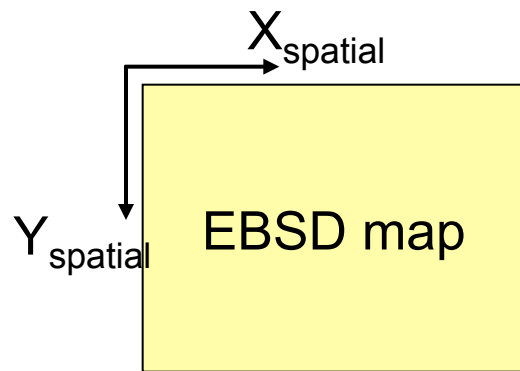

$X_{pix}, Y_{pix}$  = spatial frame  
 $X_0, Y_0, Z_0$  = euler angle frame, supposed to be aligned with  $X_1, Y_1, Z_1$  ( $\mu$ scope frame)

section reference

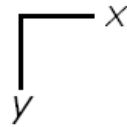

possible Euler angle reference frames

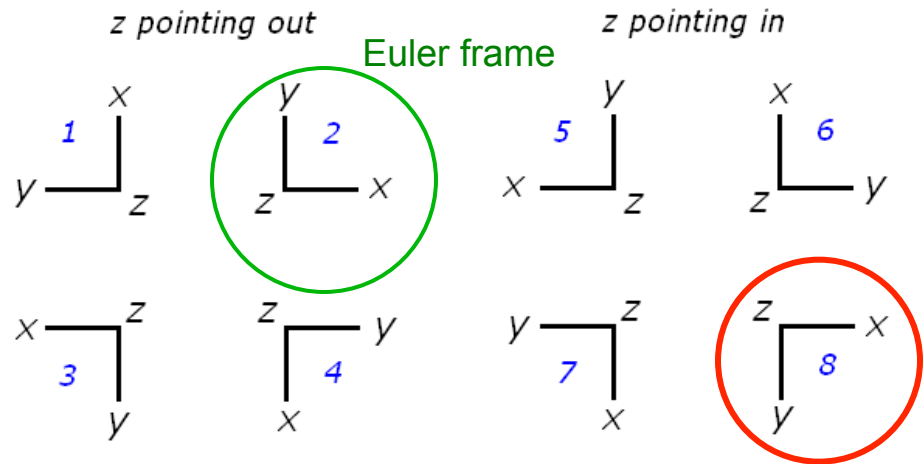

Note that a rotation of the PF axes by 180° around Z to recover the frame numbered 3 on the PF plots, would also be consistent with the trace being perpendicular to  $\langle 10-10 \rangle$ ...



# Notes on HKL Frames

---

There is a discrepancy in the HKL software between how the frame CS1 (and CS0) is represented in the virtual chamber and how the PF axes are placed

The difference is a rotation by  $180^\circ$  around the Z direction (frame numbered 2 versus frame 3)

It is not possible to determine which one is correct from the two previous slides

Nevertheless, the test maps acquired with LETAM's HKL system and with MRSEC's TSL one did show that the frame number 2 was the correct one

---

# Orientation Distribution Functions

---

- The ODF displays how the measured orientations are distributed in orientation space
- Two types of distributions can be calculated:

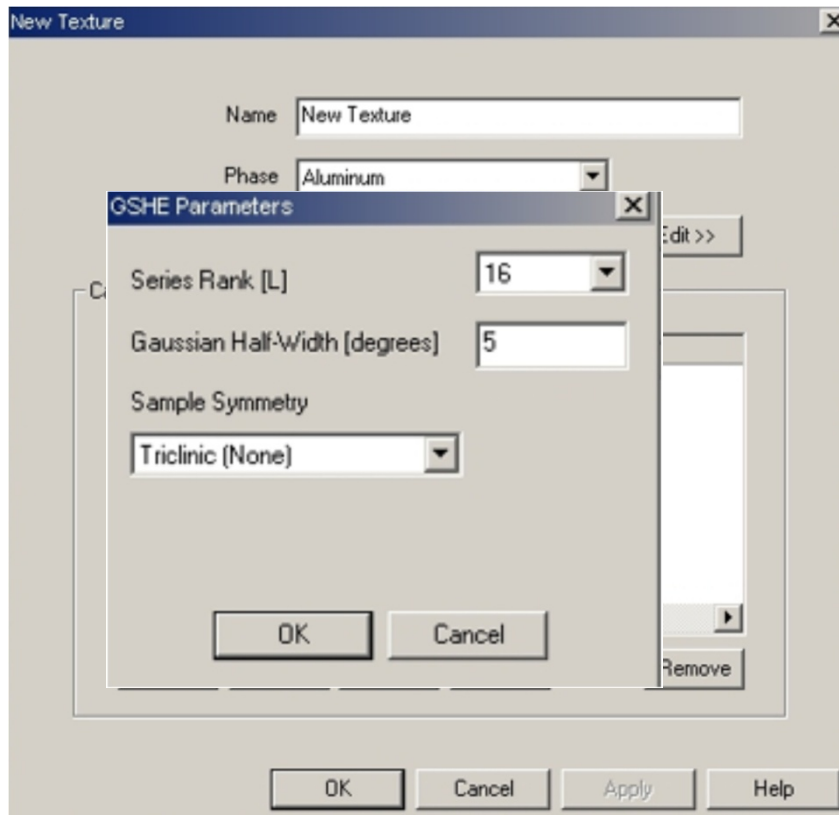

## Continuous ODF:

- Generalized Spherical Harmonic Functions: Rank defines the “resolution” of the function
  - Equivalent to a Fourier transform
  - Calculation time rises steeply with rank number (32 is an effective maximum)
  - Time intensive
  - Mostly appropriate for weaker textures
  - Some smoothing is inherent
-

# Plotting Orientation Distributions

- One must select the types of data visualization desired

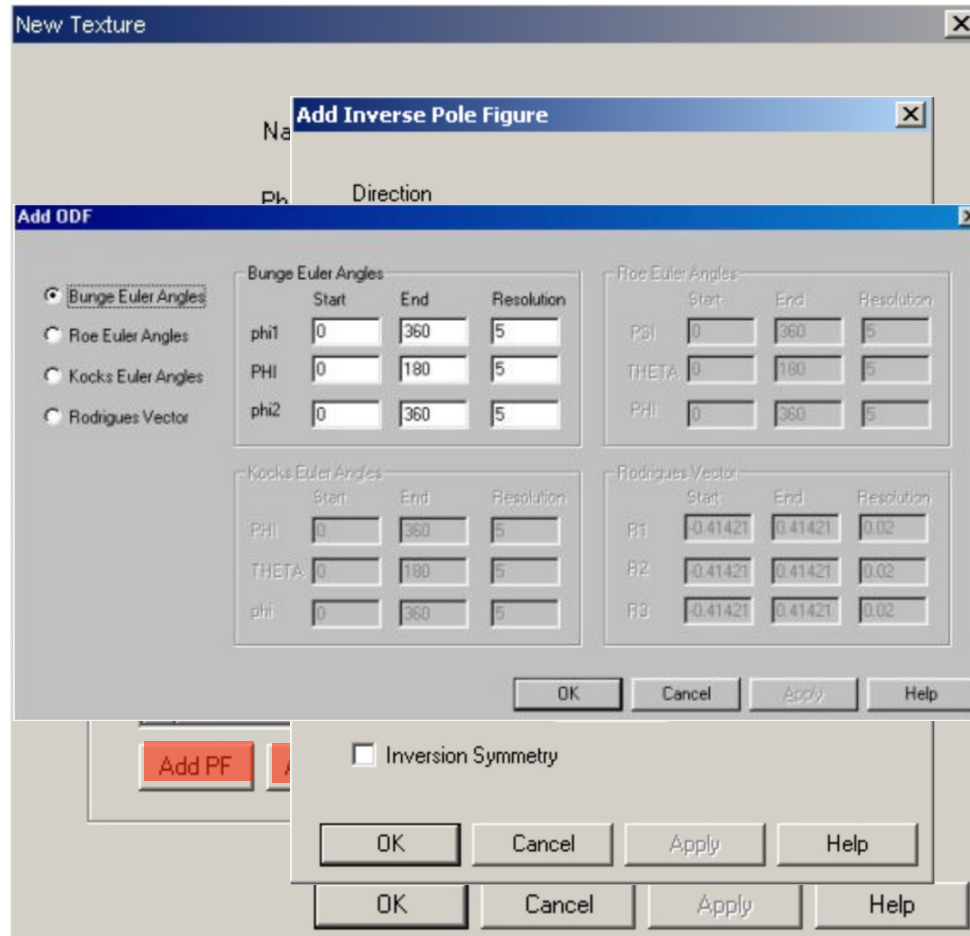

- Euler space plot shows the distribution of intensity as a function of the Euler angles
- Used to visualize pockets of texture as well as “fiber” textures
- Resolution defines how many slices are possible in the plot to be entered one at a time

# Types of ODF/Pole Figure/ Inverse PF Plots

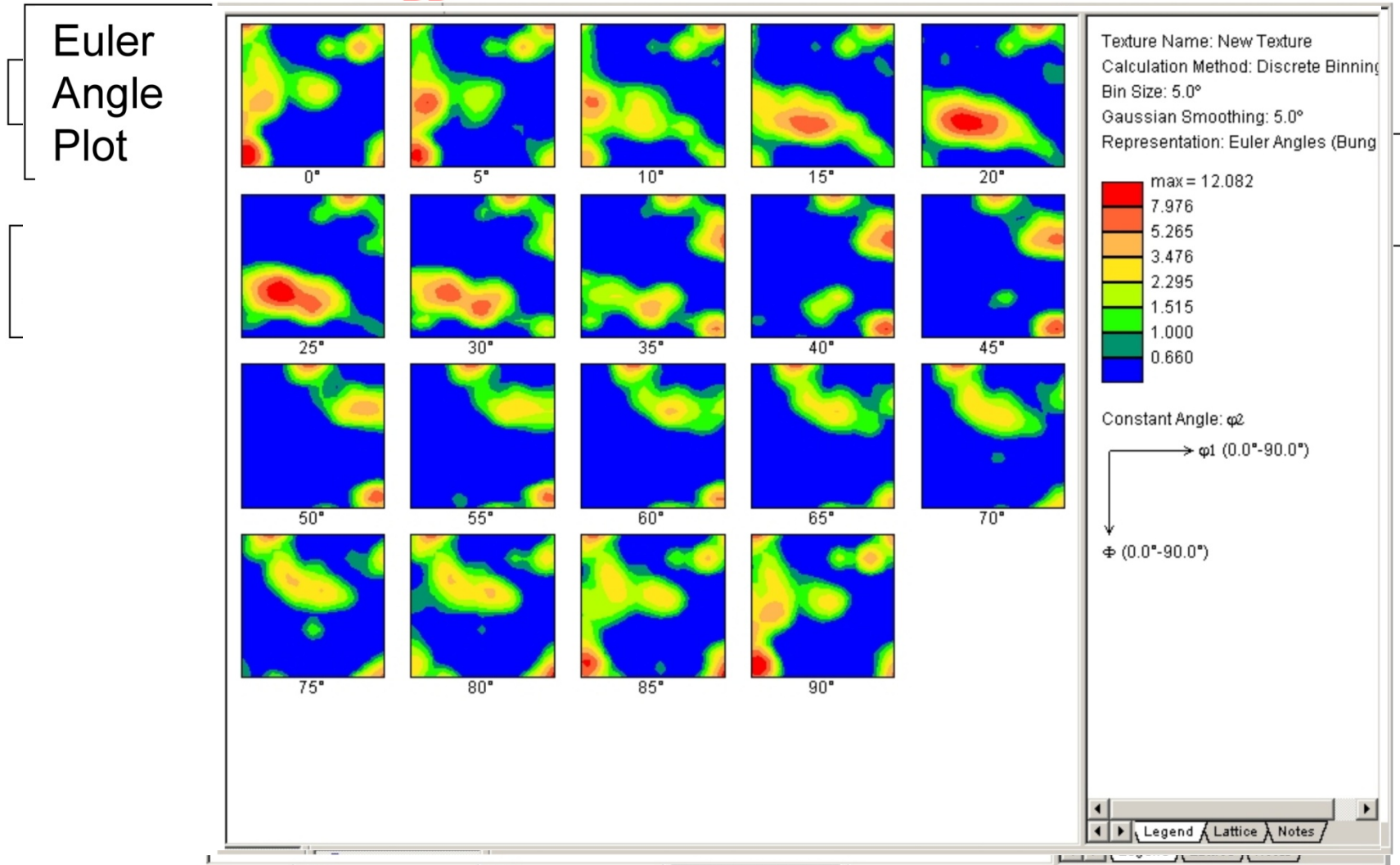

**NB: a more comprehensive discussion of reference frames is given later**

# Preparation of the data for analysis

The *Average Orientation* of the pixels in a grain is given by this equation:

$$\bar{q} = (q^1 + q^2 + \dots + q^N) / \|q^1 + q^2 + \dots + q^N\|.$$

Very simple, n'est-ce pas?

However, there is a problem...

As a consequence of the crystal symmetry, there are several equivalent orientations.  $i=1,24$

This example illustrates the point:

$$M(g)_{\text{équivalent}} = M(g)_{\text{mesuré}} [S_i]_{\text{cristal}}$$

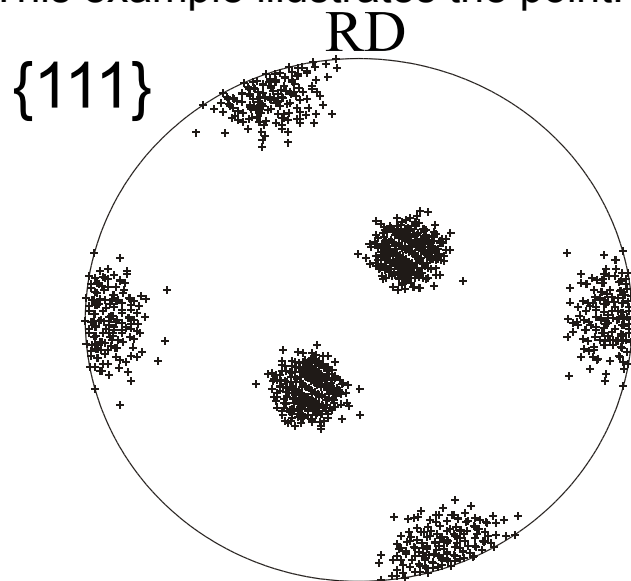

10 000 orientations near to the Brass component:

represented

- by a {111} pole figure
- and, in the complete Euler space to show the 24 equivalents resulting from application of cubic crystal symmetry

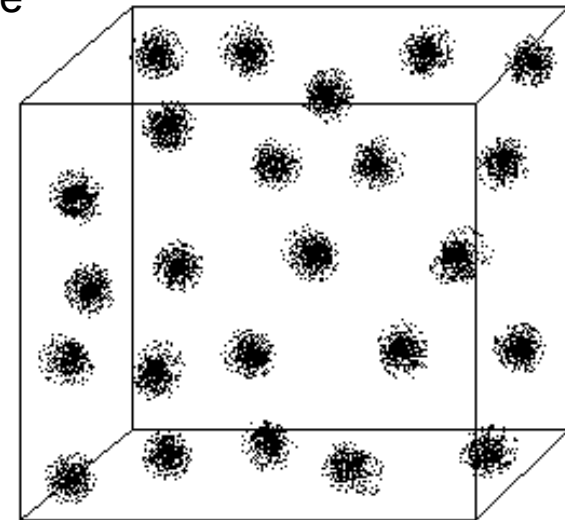



# Parameters for texture analysis: example of Zr alloy

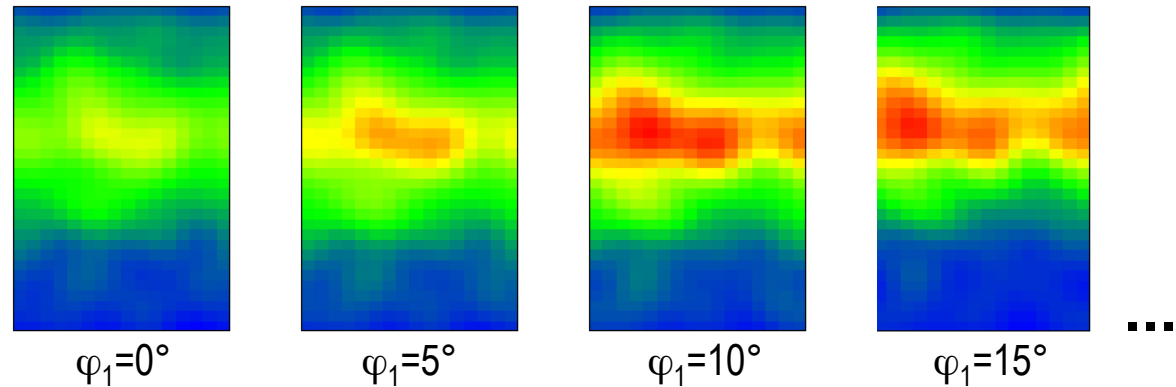
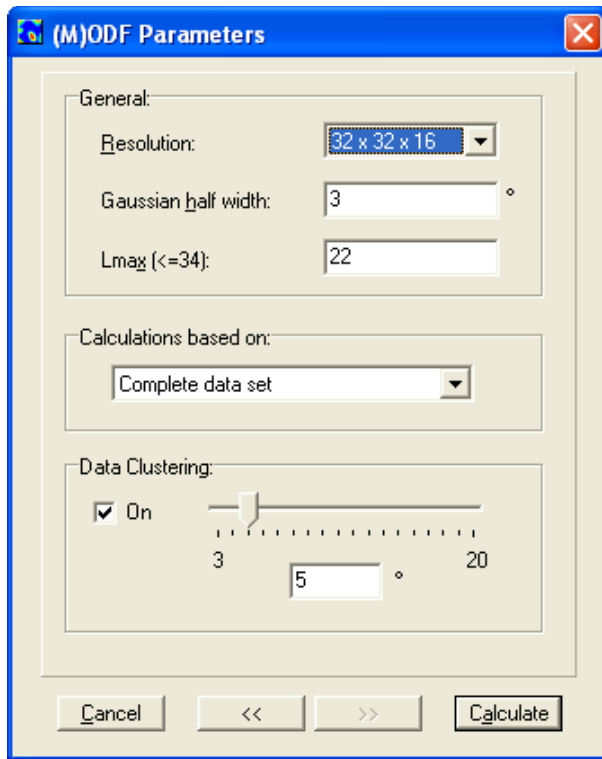

Coefficients Of The Series Expansion Of [Coeff]

Normalized

Nr	l	mu	nu	Real	Imaginary
1	0	1	0	1	0
2	2	1	-2	-0.816384	-0.558896
3	2	1	-1	-0.878014	2.11639
4	2	1	0	2.09822	0
5	2	1	1	0.878014	2.11639
6	2	1	2	-0.816384	0.558896
7	4	1	-4	0.446969	0.52539
8	4	1	-3	1.09564	-1.0229
9	4	1	-2	-1.65389	-1.55447
10	4	1	-1	-1.14281	1.88427

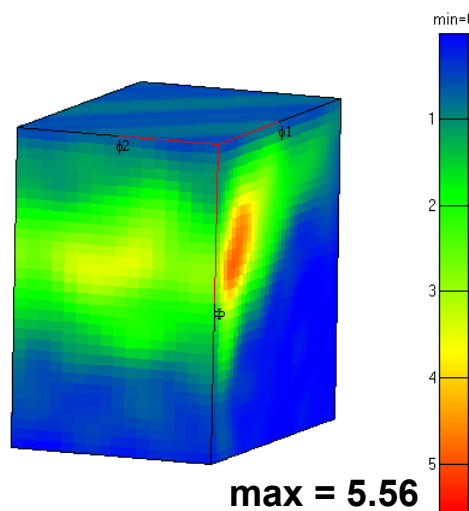

Courtesy of N. Bozzolo, CEMEF

# Parameters for texture analysis

Courtesy of N. Bozzolo

Resolution 32x32x16  
Gaussian 3°  
 $L_{\max}$  22  
Bin Size 5°

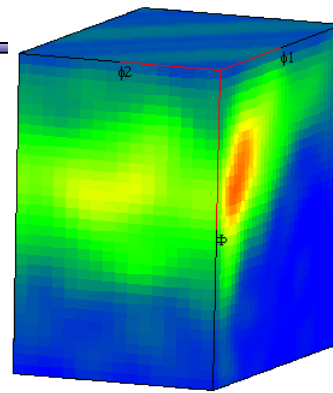

max = 5.56



## Effect of the binning resolution

**16x16x8**

3°

22

5°

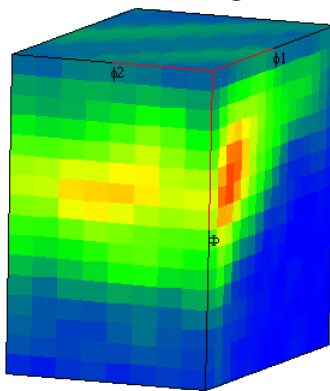

max = 5.37



## Effect of the width of the Gaussian

32x32x16

**8°**

22

5°

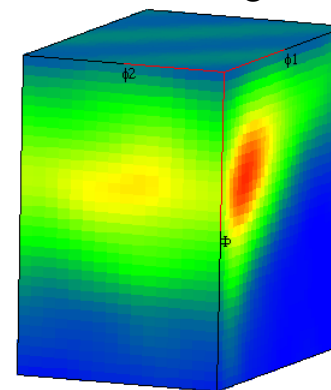

max = 4.44

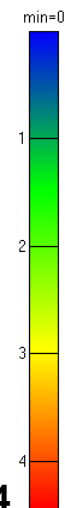

# Effect of the maximum rank in the series expansion, $L_{\max}$

---

Resolution            32x32x16  
Gaussian            3°  
 $L_{\max}$             22  
Bin Size            5°

*Courtesy of N. Bozzolo*

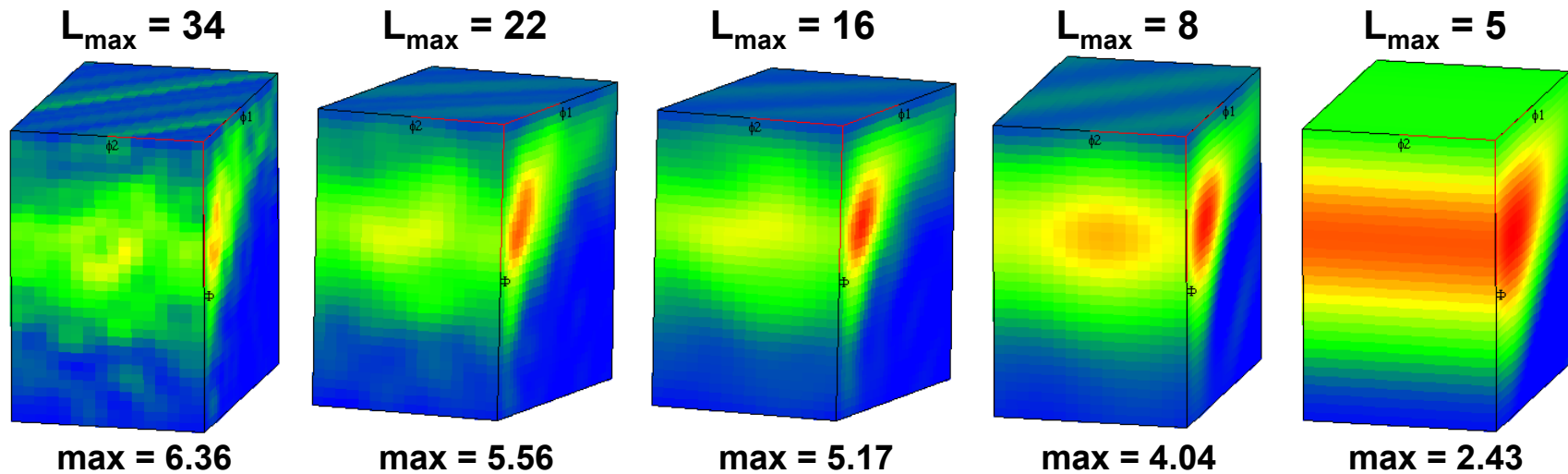

Clearly, taking the fitting to higher order (angular frequency) provides better resolution of the texture

---

# Direct Method

Courtesy of N. Bozzolo

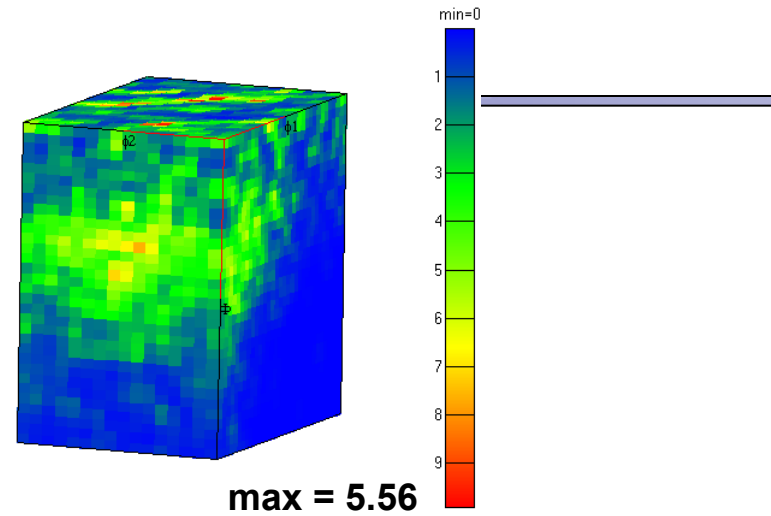
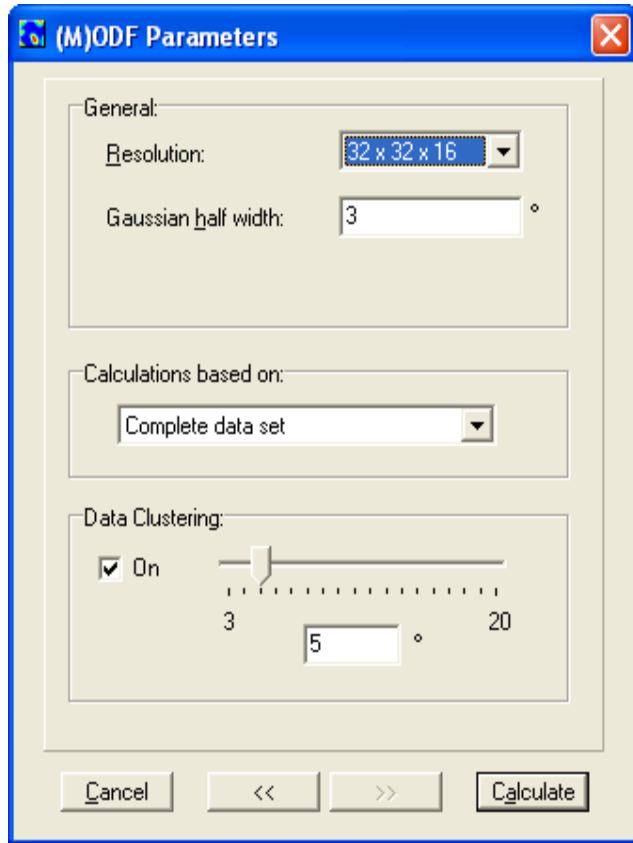

In effect the harmonic method gives some "smoothing". Without this, a coarse binning of, say, 10°, produces a very "lumpy" result because the Gaussian applied around each point is not sufficiently wide to give a continuous distribution.

Same, with 10° binning :

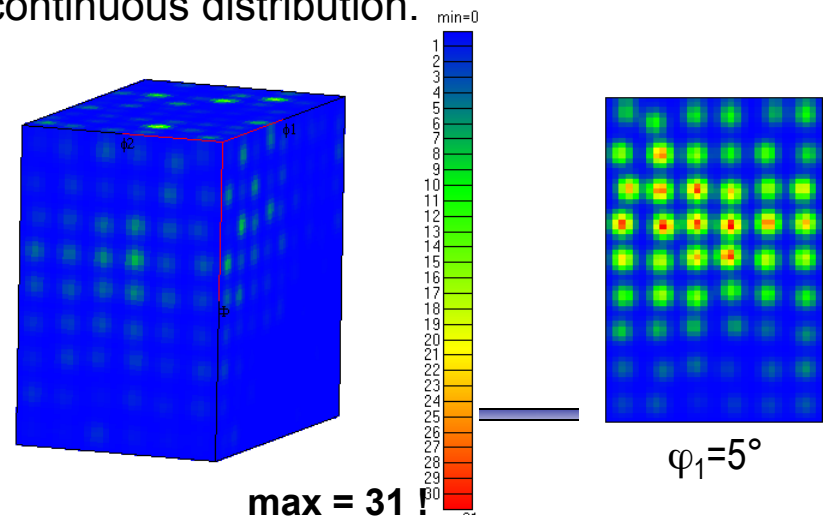

# Statistical Aspects

Texture = distribution of orientations  
 → Problem of sampling!

Triclinic sample symmetry

- Number of grains measured
- Width of the Gaussian ( and/or  $L_{\max}$ )
- Influence of the sample symmetry

Orthorhombic sample symmetry

Zirconium, equiaxed  
 Sections thru the OD at constant  $\varphi_1$  ( $L_{\max} = 34$ )

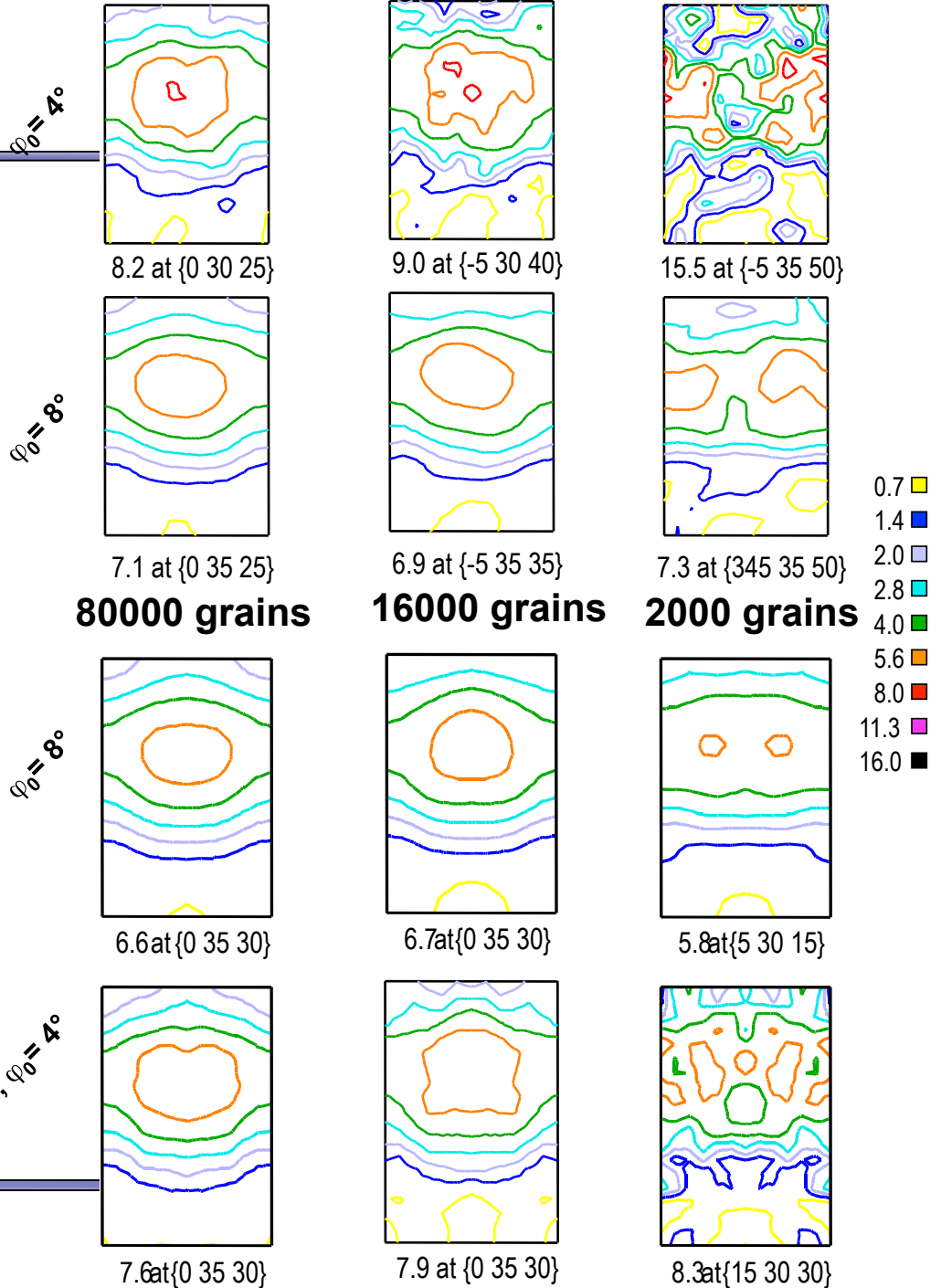

Courtesy of N. Bozzolo

# Statistical Aspects Homogeneity/heterogeneity of the specimen...

Not just the number of grains must be considered but also their spatial distribution:

Single EBSD map (1 mm<sup>2</sup>)

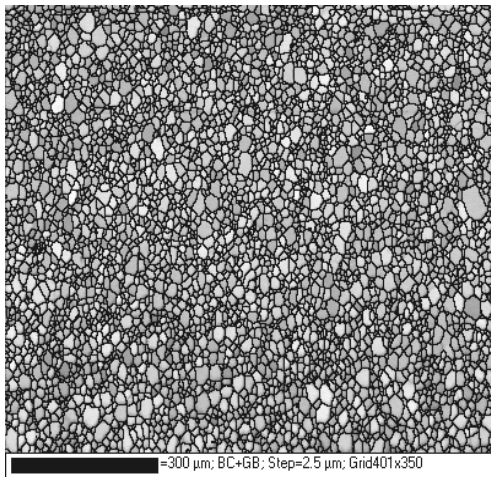

Multiple maps, different locations ( total =1 mm<sup>2</sup>)

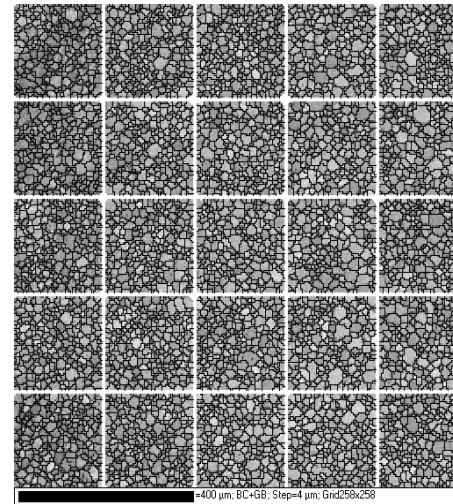

equiaxed Ti

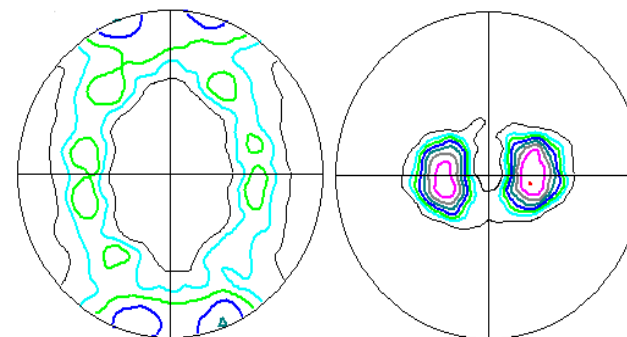
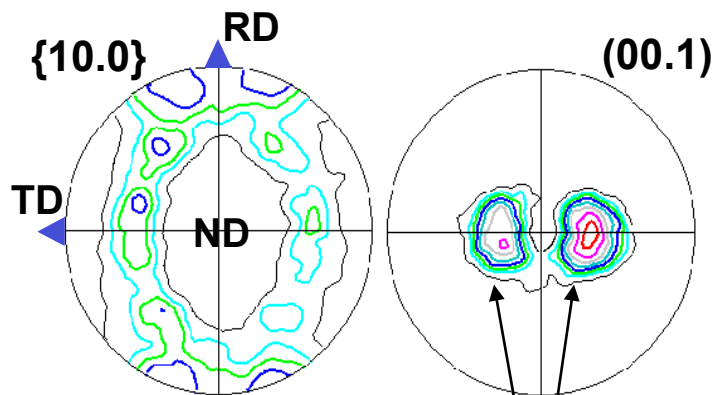

asymmetry  
of intensity

# Texture – Microstructure Coupling

Example : partial texture of populations of grains identified by a grain size criterion (zirconium at the end of recrystallization )

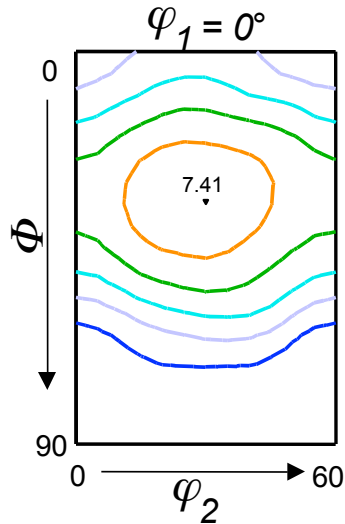

Global texture

- 0.7
- 1.4
- 2.0
- 2.8
- 4.0
- 5.6
- 8.0
- 11.3
- 16.0

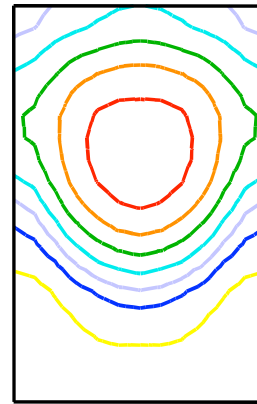

$D > \bar{D}$  (=11  $\mu\text{m}$ )  
3496 grains  
17.9% surf.

partial texture of the largest grains

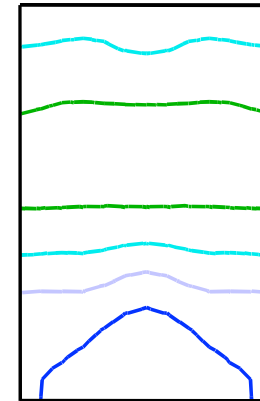

$D \leq \bar{D}/2$  (=2.75  $\mu\text{m}$ )  
14255 grains  
1.7% surf.

Partial texture of the smallest grains

Important for texture evolution during grain growth: the large grains grow at the expense of the small grains. Since the large grains have a different texture, the overall texture also changes during growth.

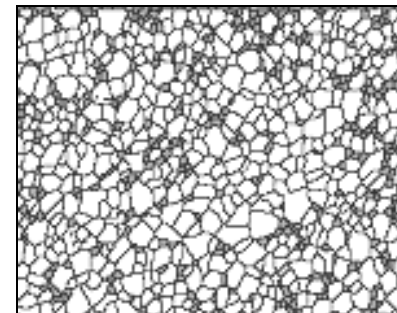
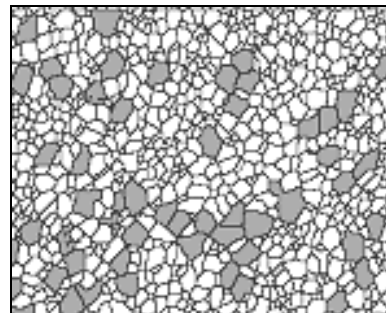

# Definition of Misorientation

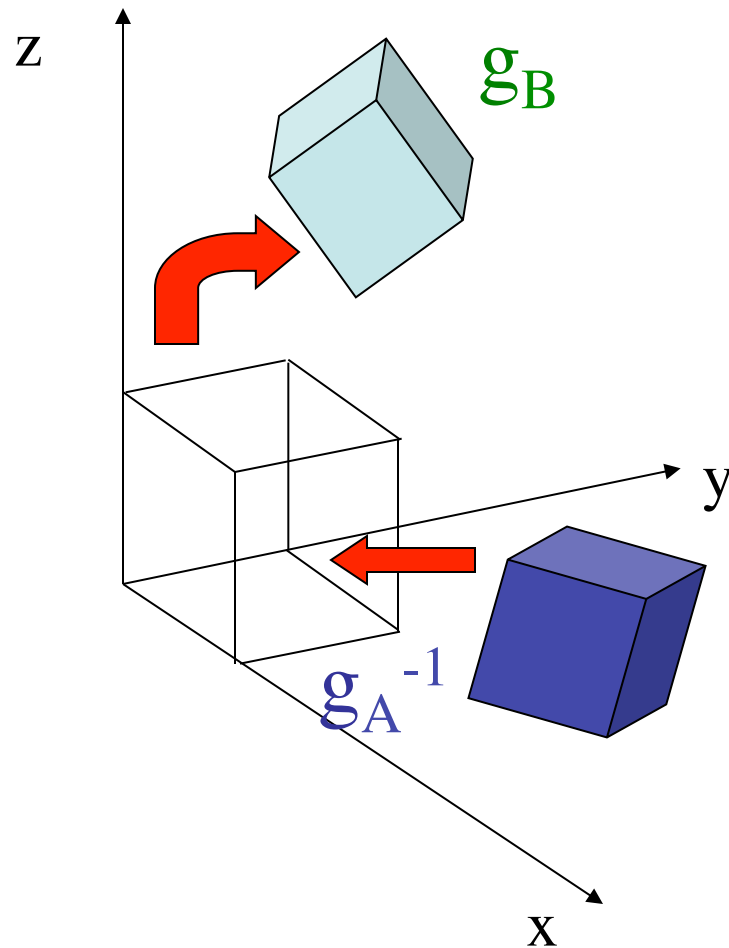

- Misorientation is an orientation defined with another crystal orientation frame as reference instead of the sample reference frame
- Thus a misorientation is the axis transformation from one point (crystal orientation) in the dataset to another point  
 $x, y, z$  are sample reference axes  
 $g_A$  is **orientation** of data point A (reference orientation) w.r.t sample reference  
 $g_B$  is **orientation** of data point B w.r.t. sample reference

$$\text{Misorientation} = g_B g_A^{-1}$$



# Misorientation Distribution Functions

- Calculating MDFs is very similar to calculating ODFs

Texture Reduced:

- Requires both Correlated and Uncorrelated MDFs to be calculated **for the same plot type**
- This MDF is simply the Correlated / Uncorrelated values
- May be used to amplify any features in the correlated MDF texture points across a G.B.

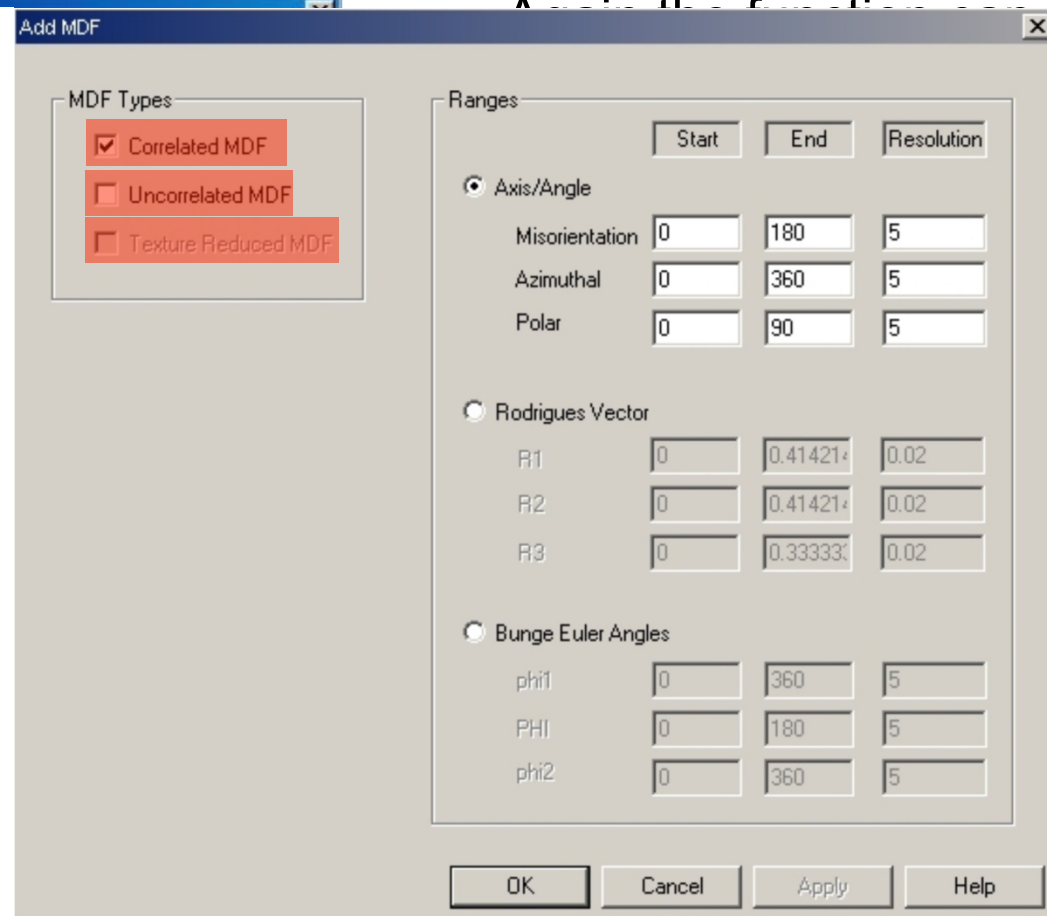

# Plotting MDFs

Select plot type  
(previously calculated)

If different types  
calculated, choose

These only apply to  
Euler angle plots

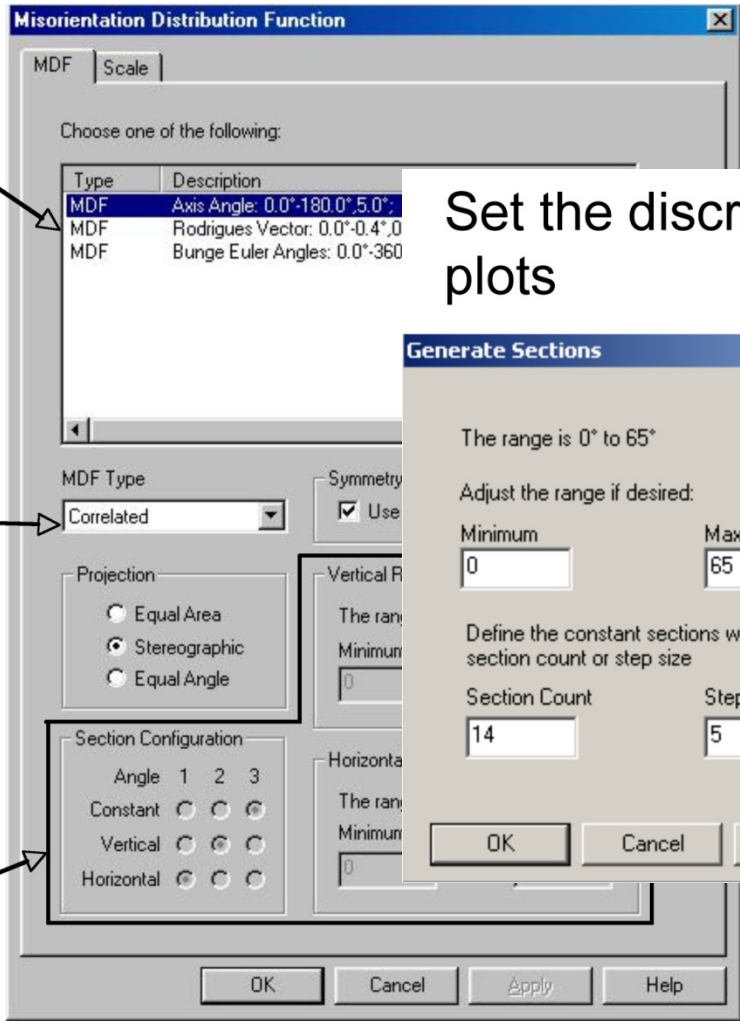

Set the discretization of the  
plots



# Sections through Misorientation Space

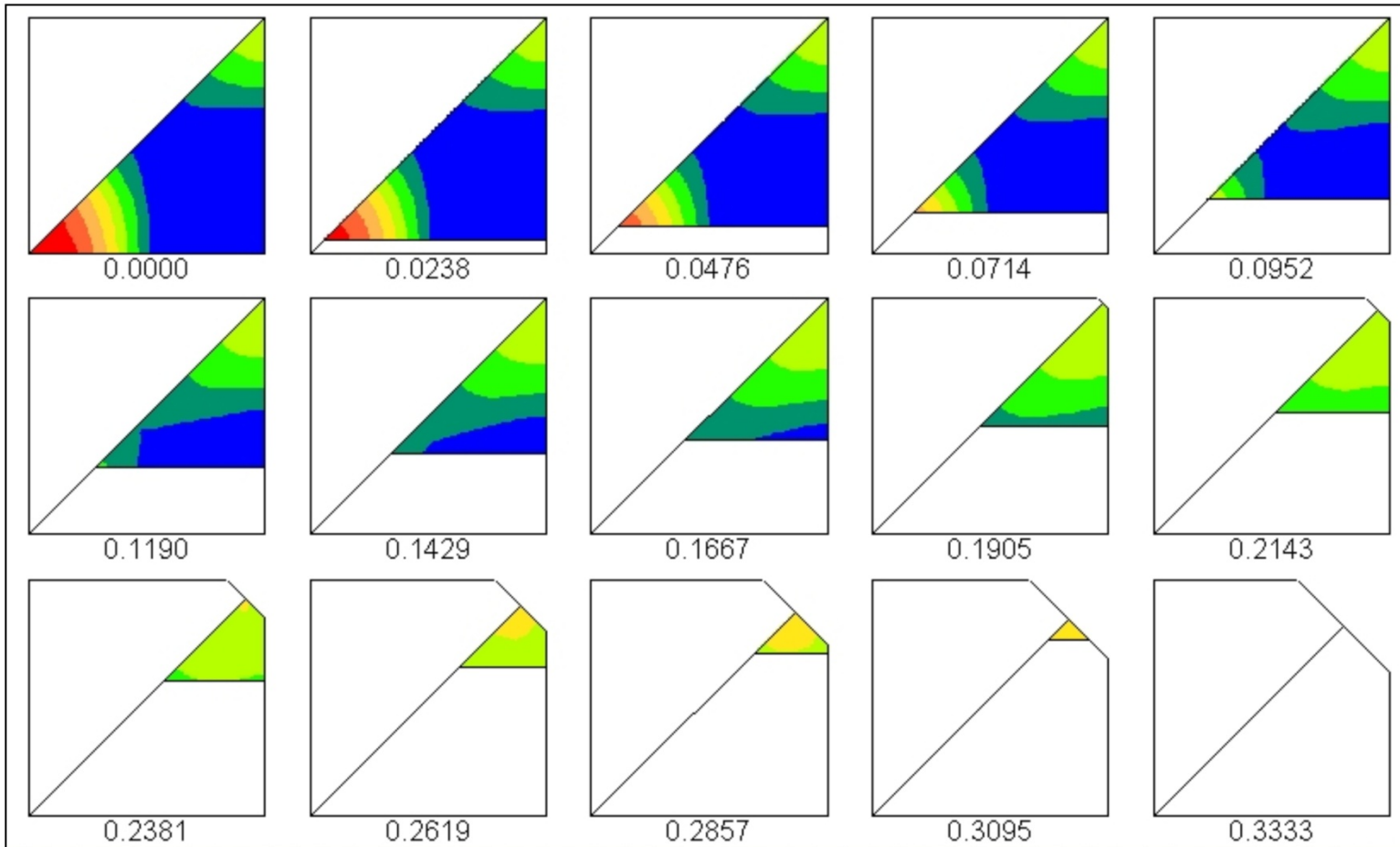

Rodrigues vector plots are shown as sections through an R-vector, usually R3

# Charts

Charts are easy to use in order to obtain s

Project1

400 200 2 crossed class

ant

Grain Size (diameter)

Image Quality

Range Parameters

Method

Percentage  Absolute

Minimum: 0 Maximum: 100

Minimum: 11.5 Maximum: 67 Average: 40.7673

Calculate

OK Cancel Apply Help

Choose plot values and range

Displays data range. You can calculate the range

Use to select partition if you have any (e.g. by grain size)

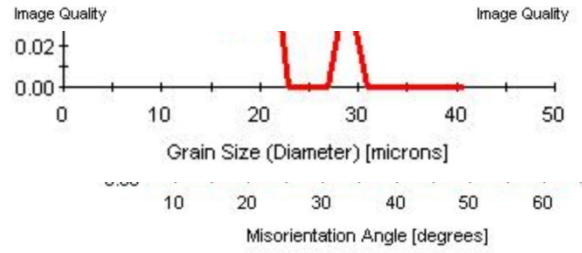
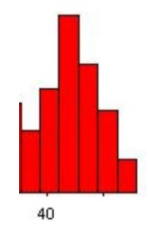
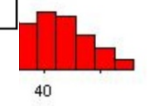
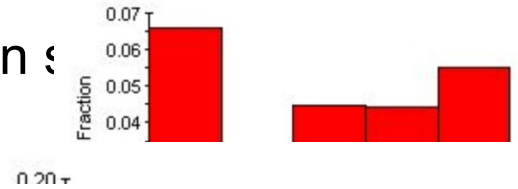

# Kernel Average Misorientation (KAM)

$$\Delta g = \{O_c\} g_B g_A^{-1} \{O_c\}$$

- For each point (orange box), compute the misorientation ( $\theta$ , angle only, purple arrows) for each nearest neighbor (26 in 3D).
  - For all values  $<$  chosen threshold ( $\psi$ , say,  $= 5^\circ$ ) compute an average value.
  - Use of a threshold eliminates any contribution from high angle boundaries.
- High values indicate orientation gradients, obviously, which are closely related to GND.
- Averaged over a grain gives Grain Ave. Misorientation (GAM)

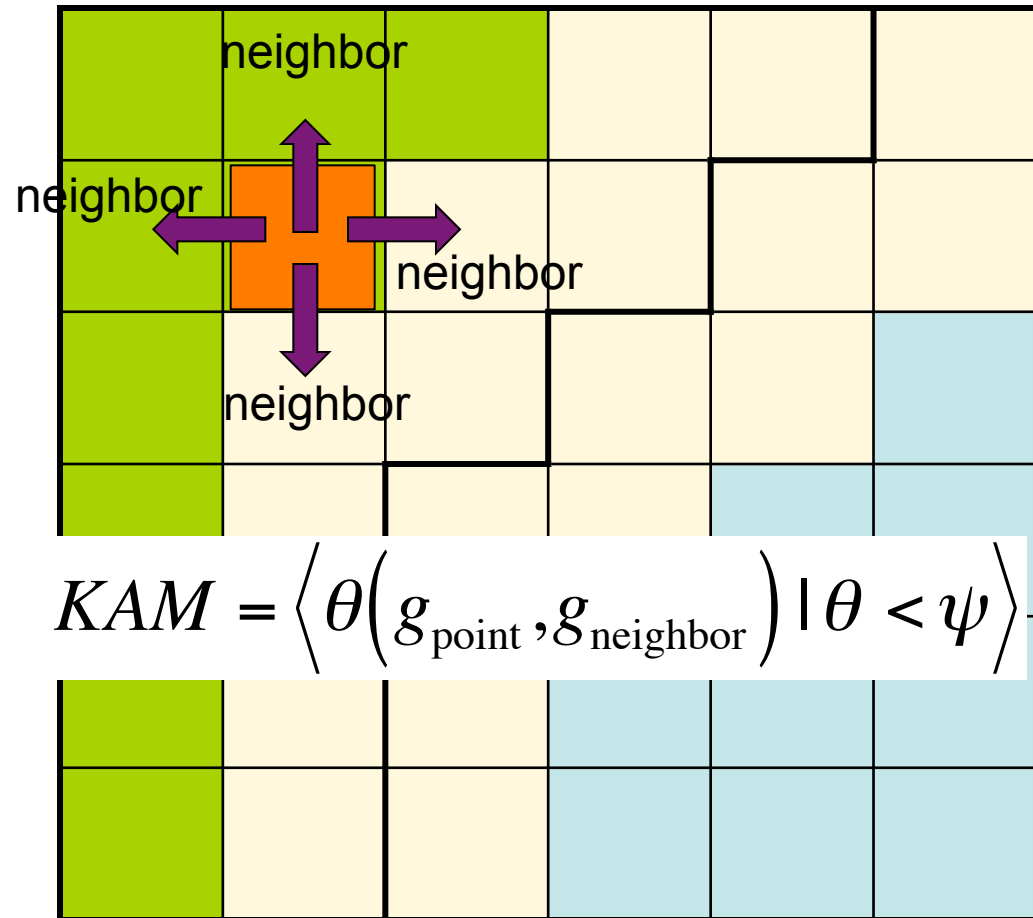

Why is KAM important? Nucleation of recrystallization, e.g.

# Intra-Granular Misorientation (IGM)

$$\Delta g = \{O_c\} g_B g_A^{-1} \{O_c\}$$

- For all points in a given grain compute an average value,  $g_{\text{GrainAverage}}$ .
- For each point, compute the misorientation ( $\theta$ , angle only) with the average orientation.
- High values indicate large differences from the grain averaged orientation.
- Variation from dark (large IGM) to light (small IGM) shows the idea.
- Sometimes called the Grain Reference Deviation (GRD).
- When averaged over the grain, one obtains the Grain Orientation Spread (GOS).

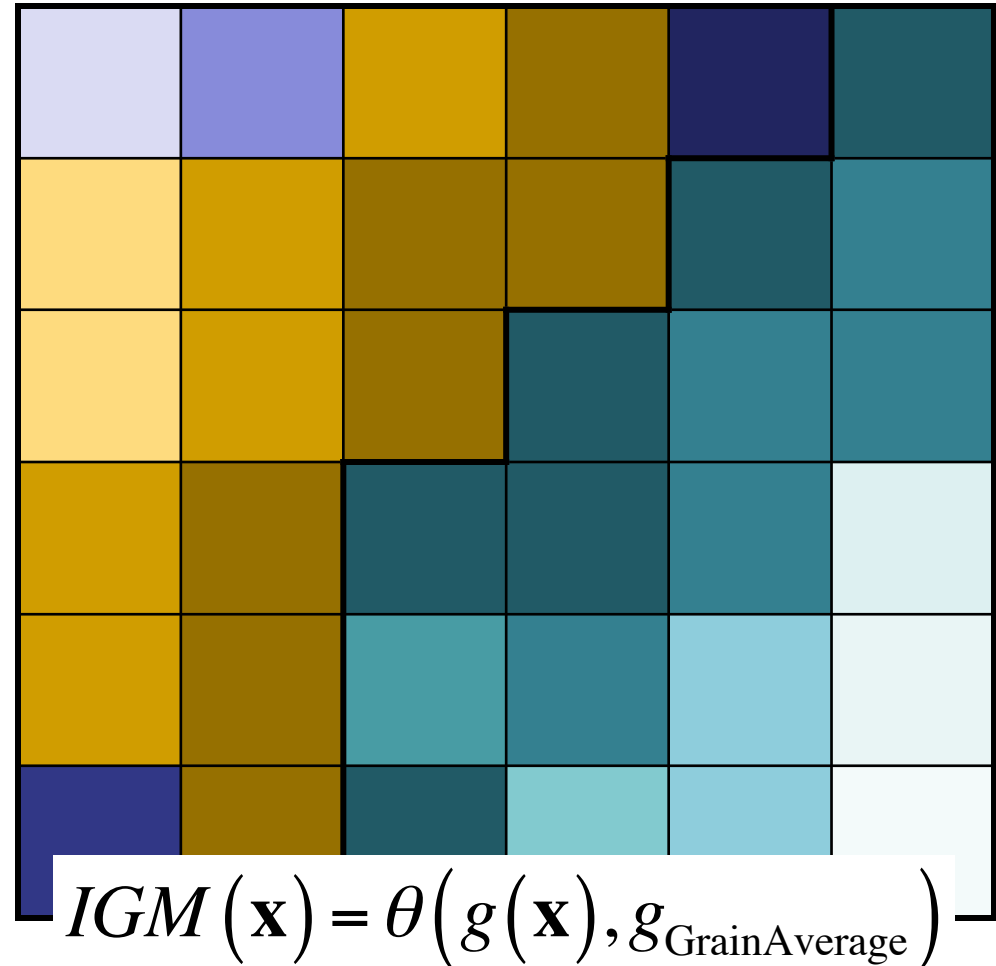

**Why is IGM important? Long range orientation gradients, for example**





# GOS and GAM

$n$  = no. nearest neighbors  
 $N$  = number of pixels

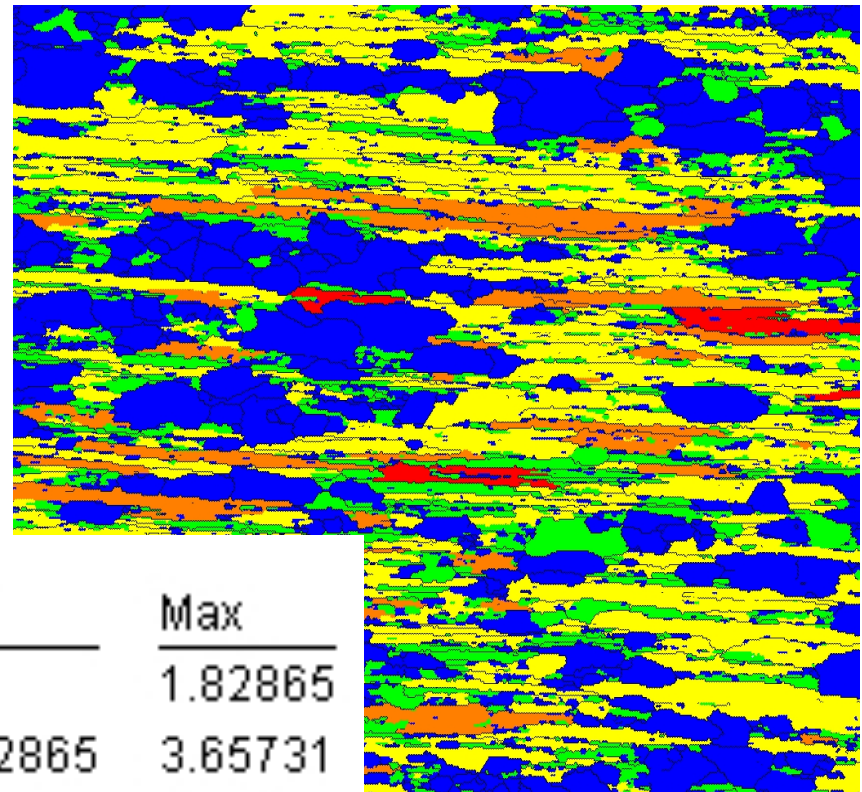
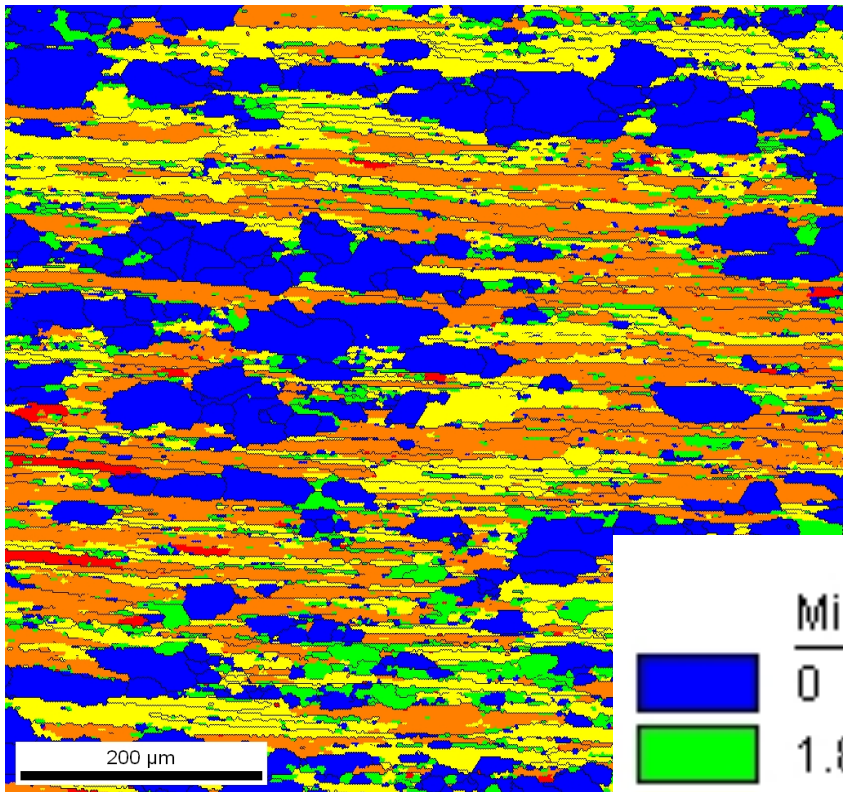
$$GAM = \frac{1}{N} \frac{1}{n} \sum_{j=1}^N \sum_{i=1}^n \Delta g_{ij}(g_i, g_j)$$

$$GOS = \frac{1}{N-1} \frac{1}{N} \sum_{j=1}^N \sum_{i=1}^N \Delta g_{ij}(g_i, g_j), \quad j \neq i$$



	Min	Max
	0	1.82865
	1.82865	3.65731
	3.65731	5.48596
	5.48596	7.31461
	7.31461	9.14327

GAM  
 Nearest neighbor pixel pair  
 ⇒ short range orientation

irs  
 ge orientation gradients

*M.H. Alvi*

# GOS and GAM

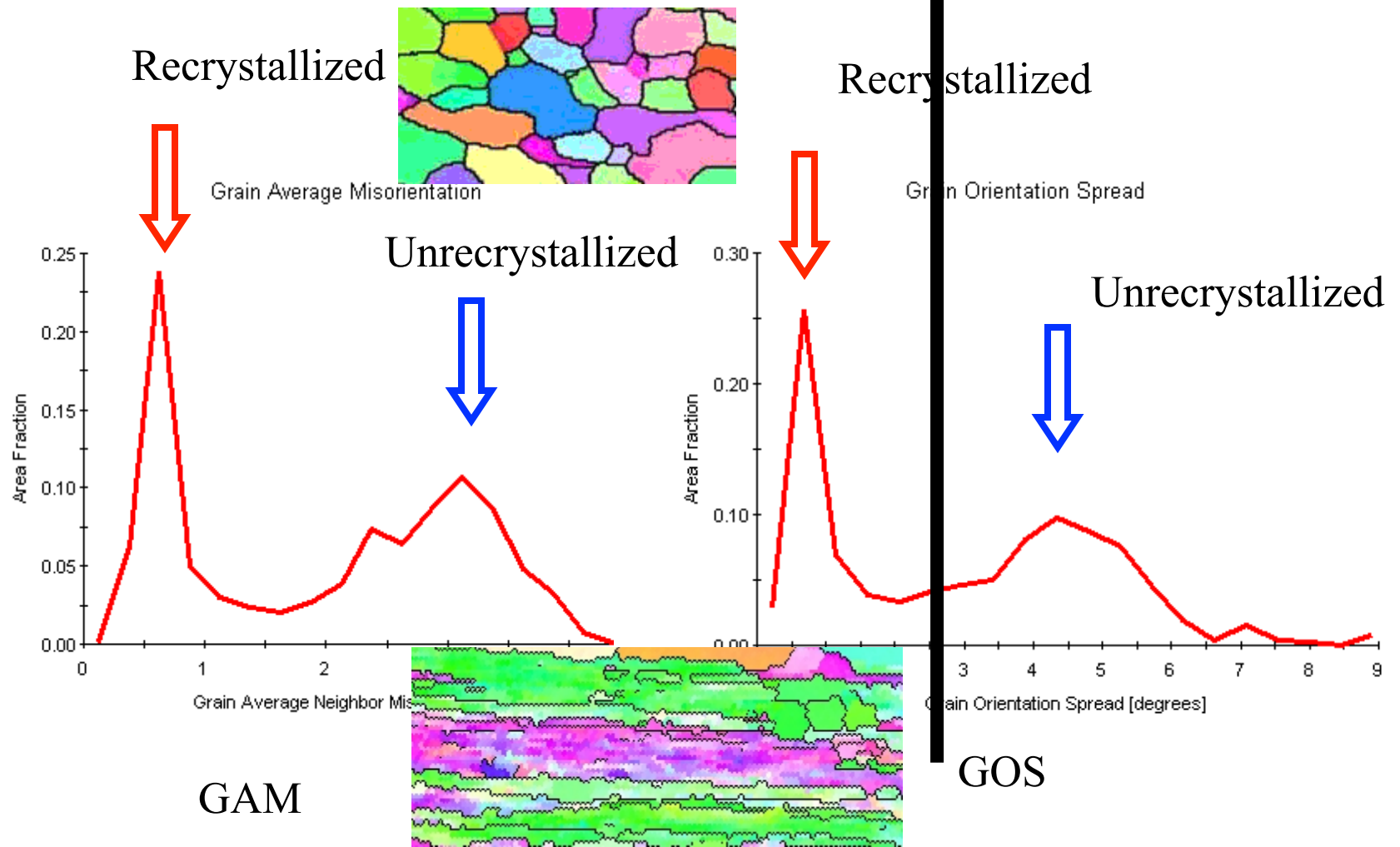

Overlapping peaks for deformed and recrystallized regions



# Partitioned scan: threshold GOS = 3°

Deformed  
Grains

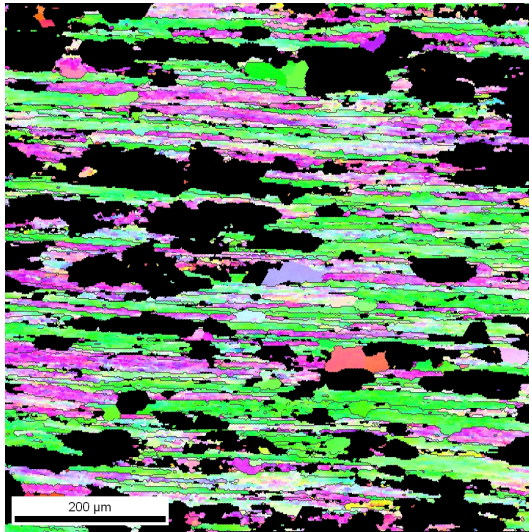

Recrystallized  
Grains

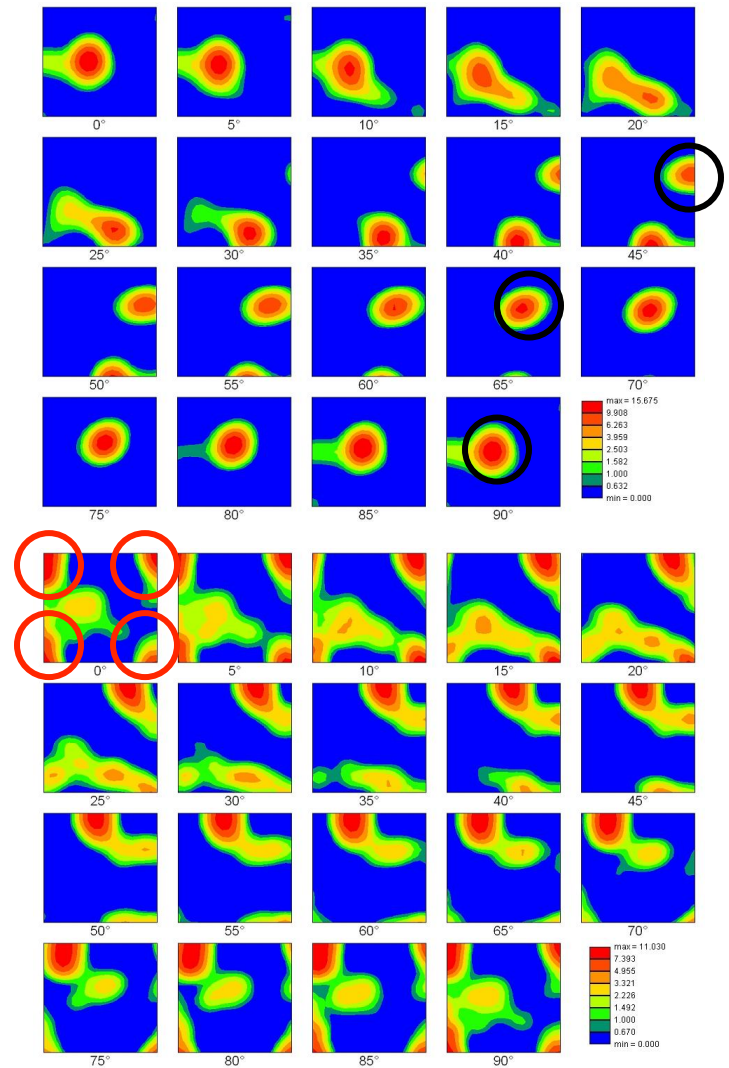
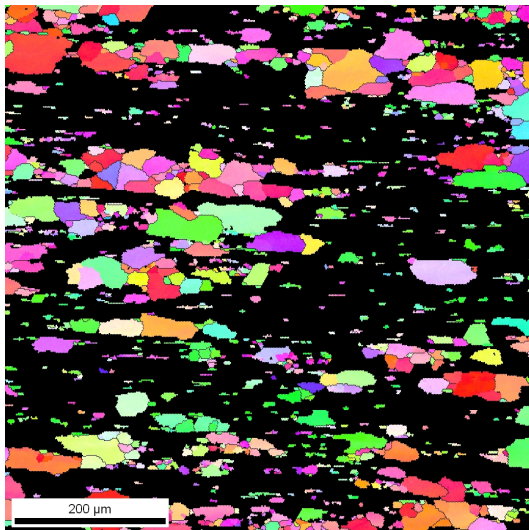

“Cube texture in hot rolled Aluminum Alloy 1050 (AA1050) - nucleation and growth behavior”, M. H. Alvi, S. W. Cheong, J. P. Suni, H. Weiland, A. D. Rollett, *Acta materialia*, **56** 3098-3108 (2008).

# As-deformed Fe-1%Si

As 1.5% temper-rolled

As 8% temper-rolled

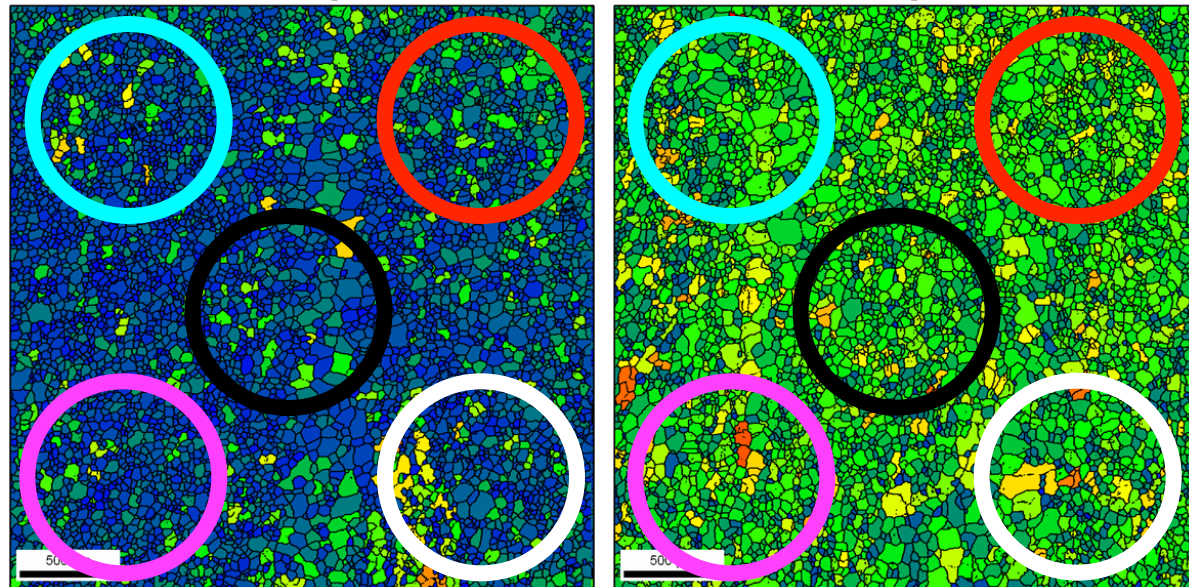

Intergranular variations in GOS greater in 8% temper-rolled material.

AGG is a local phenomenon.

AGG occurs more readily in 8% material because of greater local intergranular orientation gradients.

Density of abnormally large grains will be higher in the 8% material.

Presence of several same-stored-energy regions in 1.5% material leads to lower density of abnormally large grains.

Grains that grow abnormally already exist in the as-deformed material.

Maps shaded according to GOS.

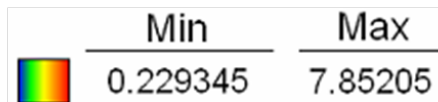

# Orientation Spread, Fe-1%Si

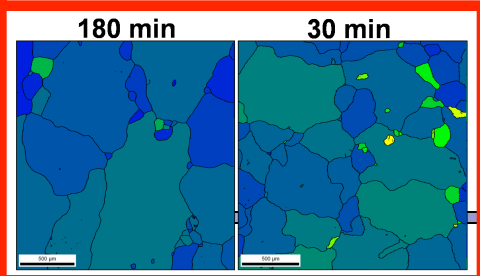
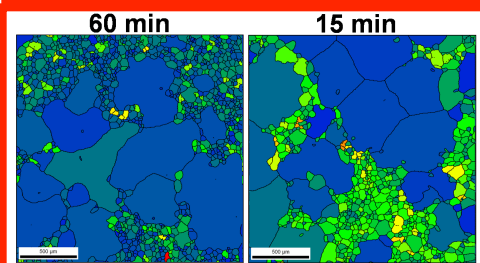
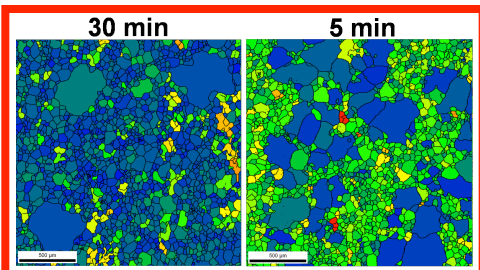
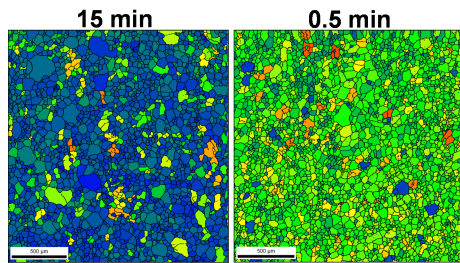

1.5% and 8% temper-rolled Fe-1%Si, annealed in air at 787°C for various times.

1.5% temper-rolled

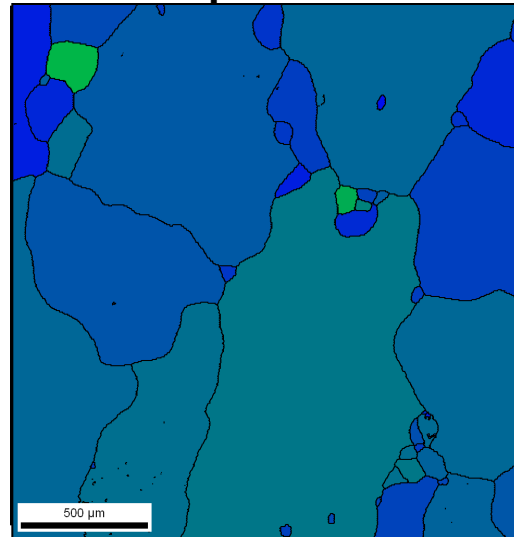

180 min.

8% temper-rolled

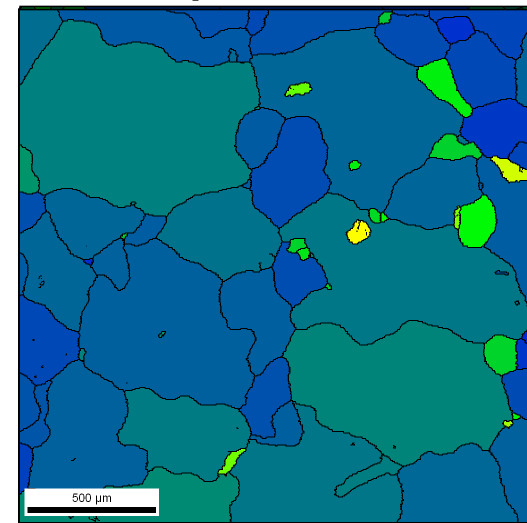

30 min.

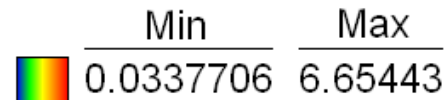

*T.A. Bennett*

**Overall, GOS decreases with annealing time.**

# Pure Nb: Longitudinal Section Etched

3mm from top of cavity

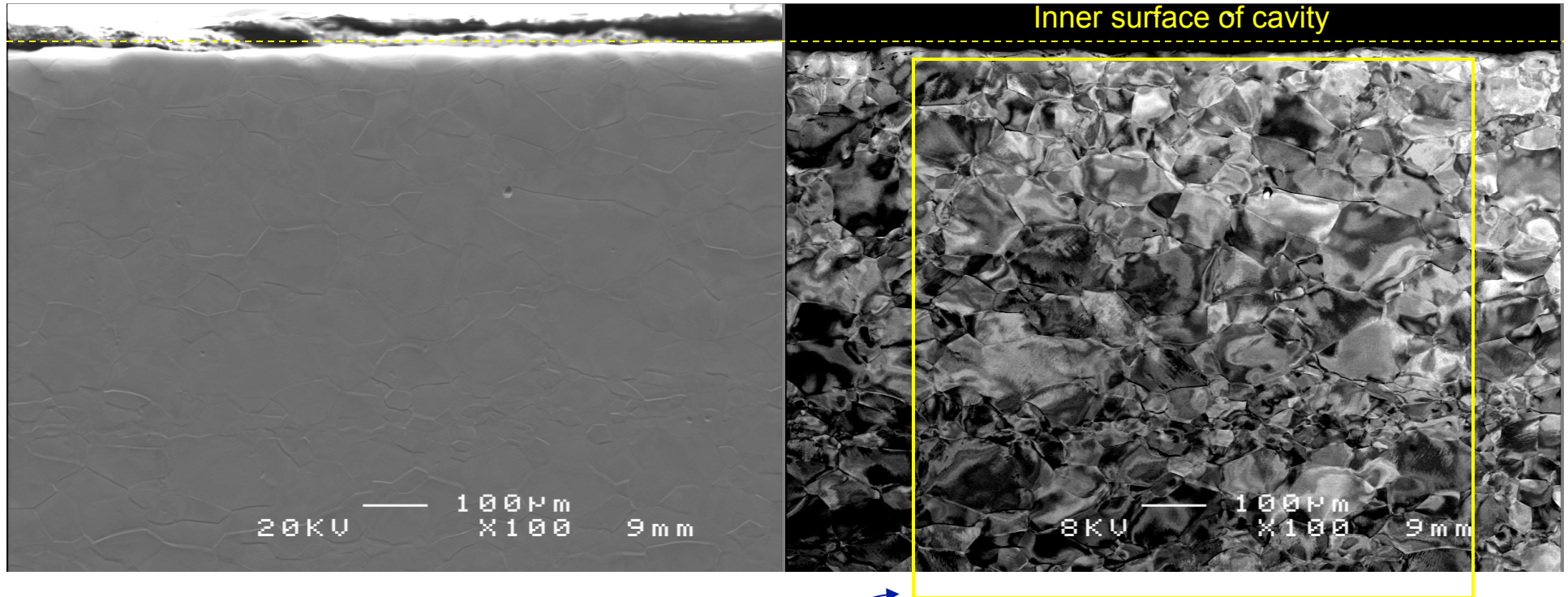

Secondary electron image

Backscattered electron image

EBSD Grid

# Nb: EBSD IPF Map

*R. Crooks*

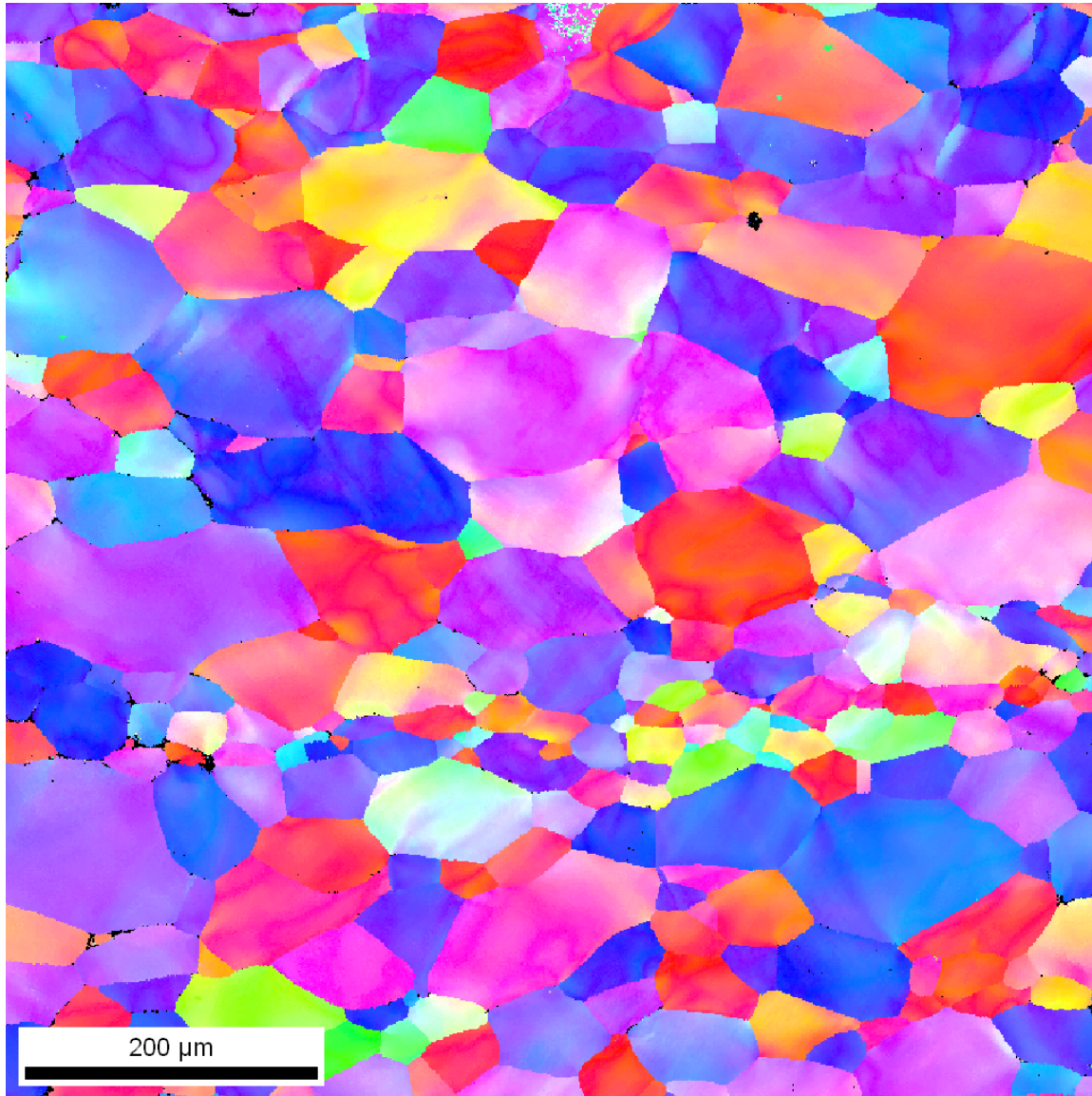

Crystal directions normal to sheet surface

Color Coded Map Type: Inverse Pole Figure [001]

Nb

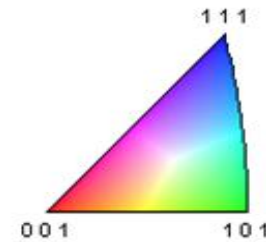

Boundaries: <none>

Color changes within grain show distortion of crystal

95% hit rate, 560,200 data points, 1 μm spatial resolution

# Nb: EBSD GOS Map

## Strain in isolated grains

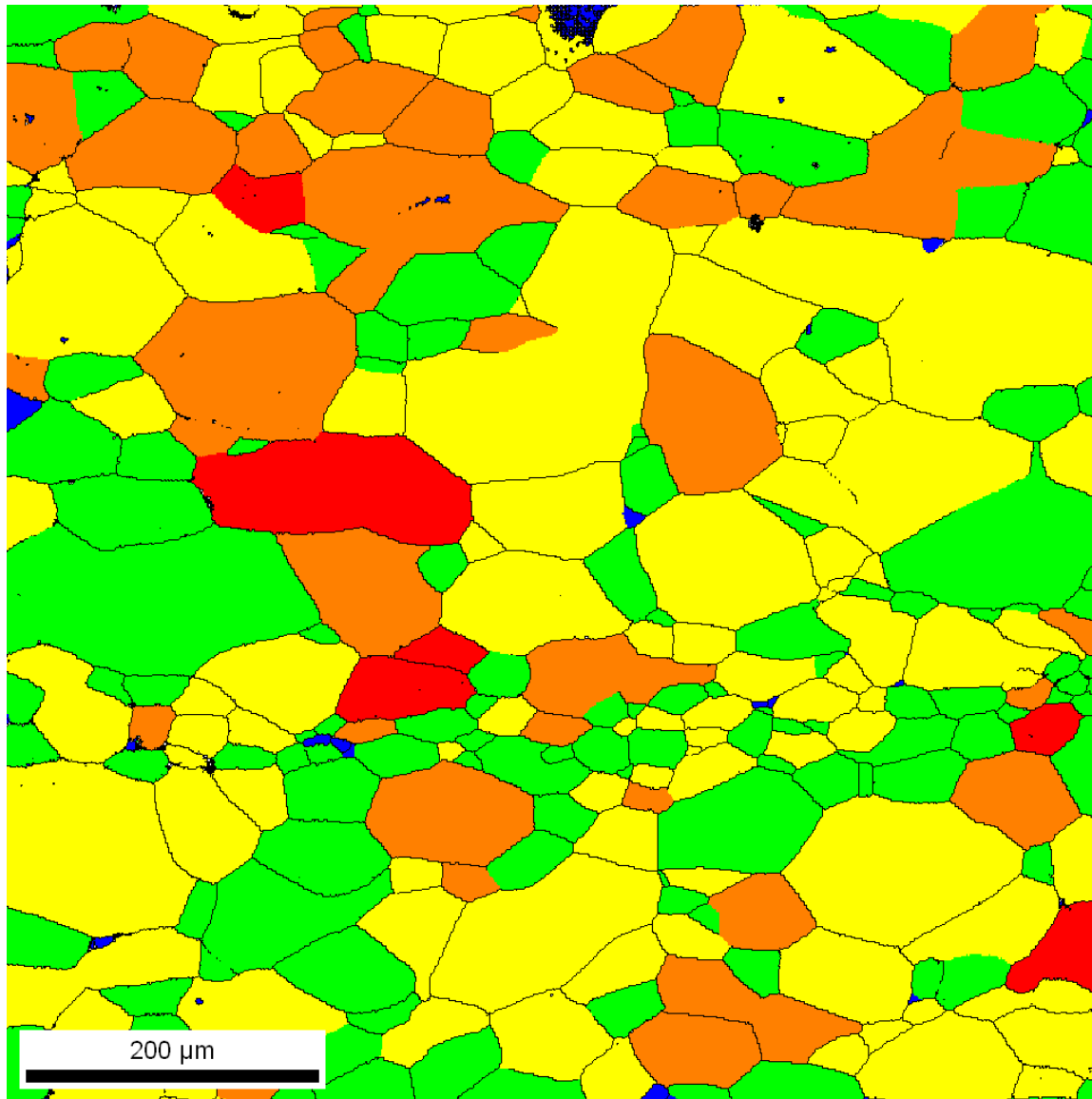

GOS: The average orientation is first calculated for each grain. The spread is then the average deviation between the orientation of each point in the grain and the grain average.

Color Coded Map Type: Grain Orientation Spread

	Min	Max	Total Fraction	Partition Fraction
Blue	0	1.22203	0.004	0.004
Green	1.22203	2.44406	0.275	0.275
Yellow	2.44406	3.66609	0.478	0.478
Orange	3.66609	4.88812	0.202	0.202
Red	4.88812	6.11016	0.038	0.038

Boundaries: Rotation Angle

	Min	Max	Fraction	Number	Length
Black line	15°	180°	0.024	26493	2.65 cm

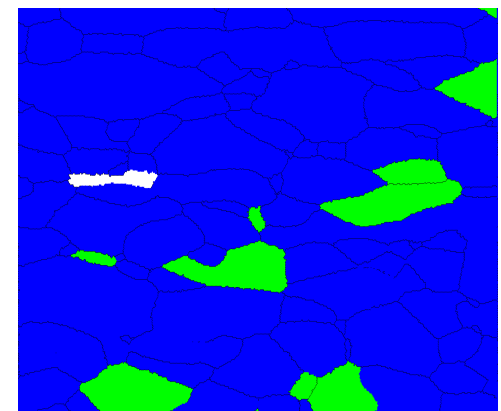

*R. Crooks*

1  $\mu\text{m}$  spatial resolution

As-received sheet

# Nb: EBSD KAM Map

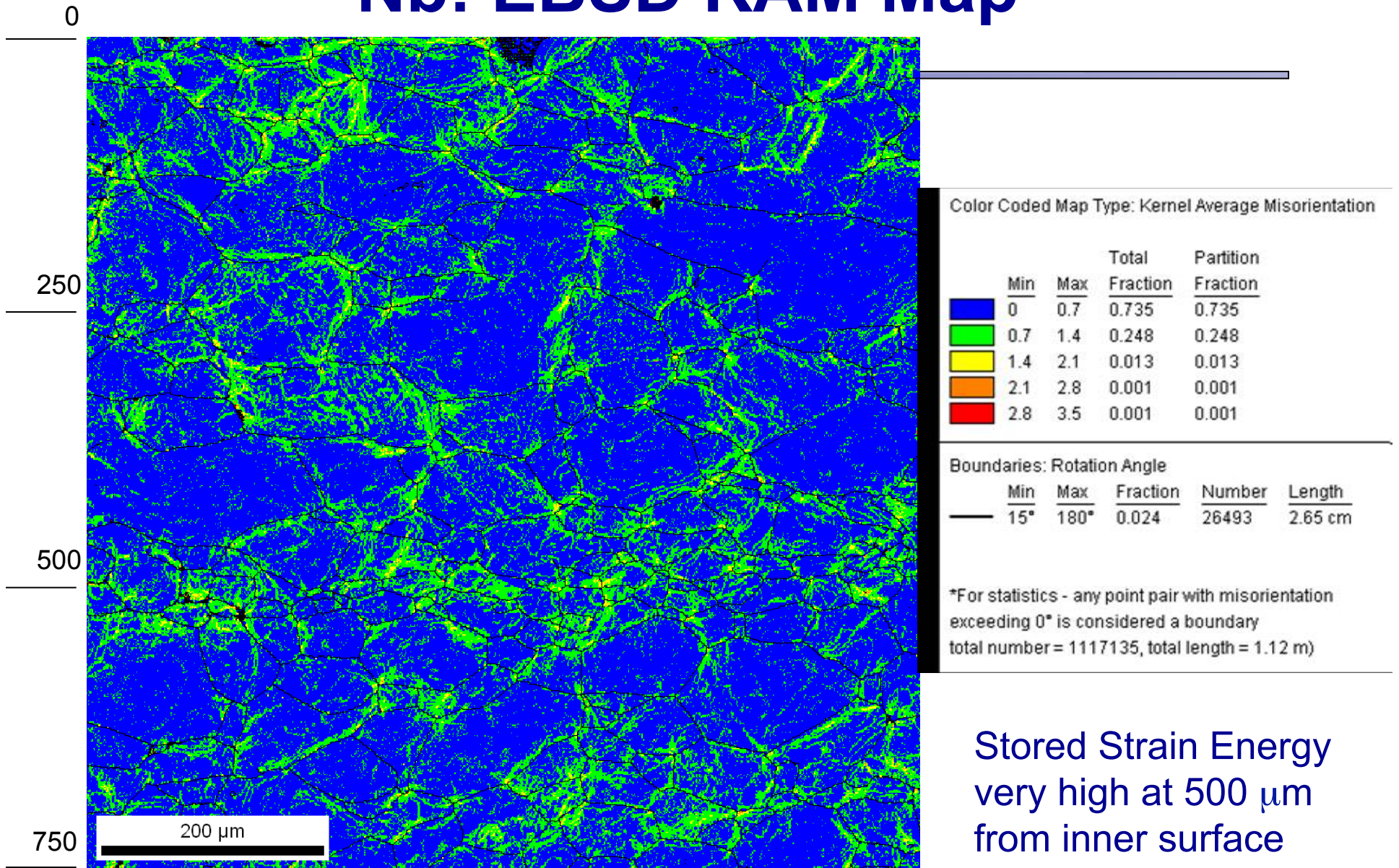

Stored Strain Energy  
very high at 500 μm  
from inner surface

# Nb: EBSD IPF Map 500 $\mu\text{m}$ deep

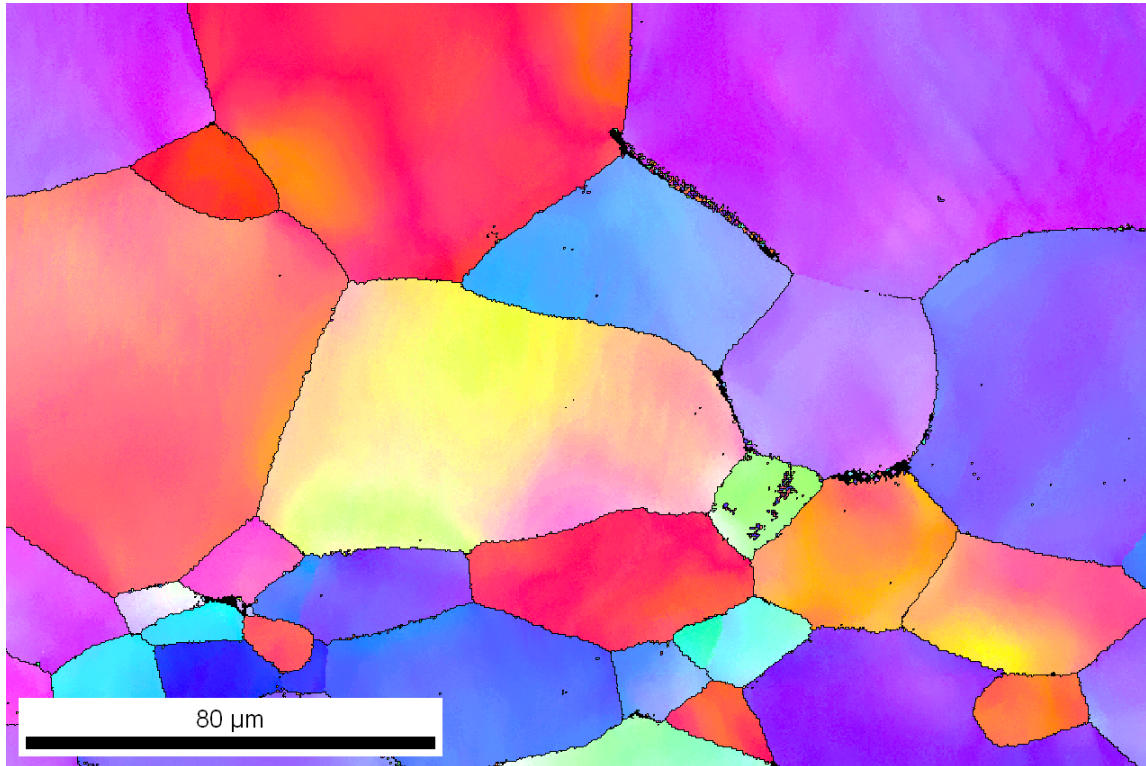

Color Coded Map Type: Inverse Pole Figure [001]

Nb

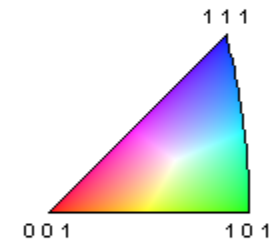

Boundaries: Rotation Angle

	Min	Max	Fraction	Number	Length
—	15°	180°	0.011	8093	2.43 mm

\*For statistics - any point pair with misorientation exceeding 0° is considered a boundary  
total number = 743433, total length = 22.30 cm)

750 x 500, 0.3  $\mu\text{m}$  spatial resolution



# Nb: EBSD GOS Map 500 $\mu\text{m}$ deep

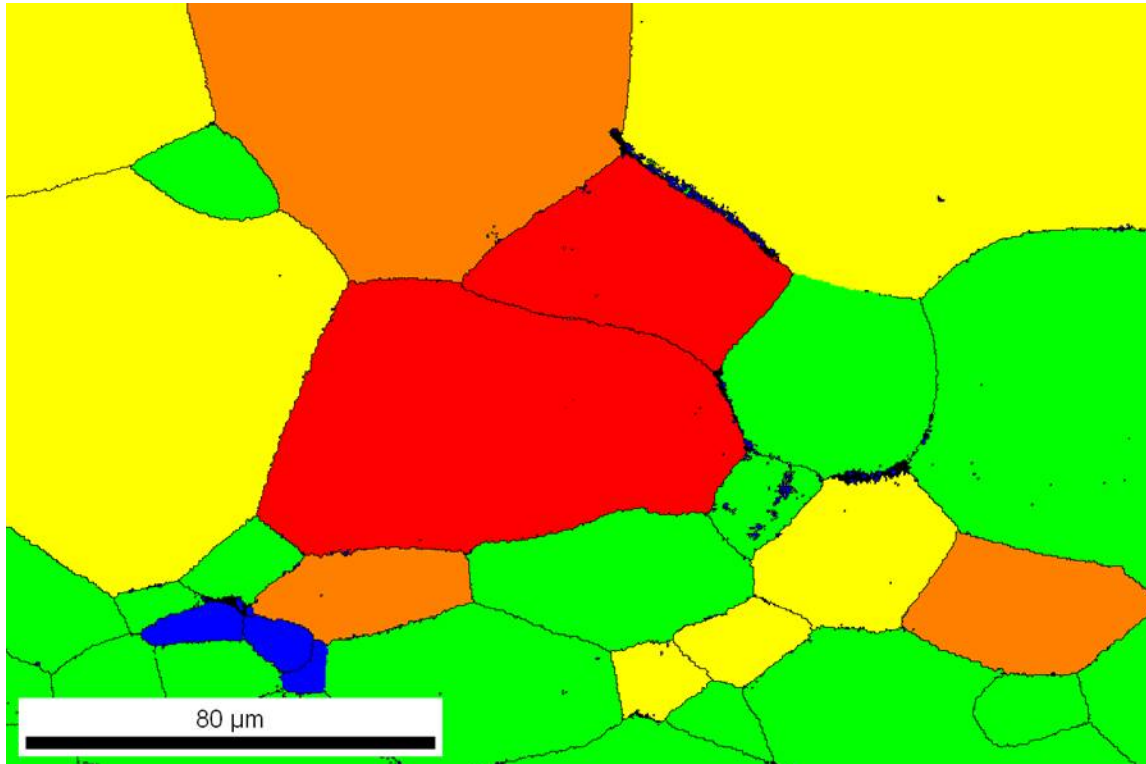

Color Coded Map Type: Grain Orientation Spread

	Min	Max	Total Fraction	Partition Fraction
Blue	0	1.14192	0.010	0.010
Green	1.14192	2.28385	0.343	0.343
Yellow	2.28385	3.42577	0.341	0.341
Orange	3.42577	4.5677	0.149	0.149
Red	4.5677	5.70962	0.153	0.153

Boundaries: Rotation Angle

	Min	Max	Fraction	Number	Length
—	15°	180°	0.011	8093	2.43 mm

\*For statistics - any point pair with misorientation exceeding 0° is considered a boundary  
total number = 743433, total length = 22.30 cm)

0.3  $\mu\text{m}$  spatial resolution

# Nb: EBSD KAM Map 500 $\mu\text{m}$ deep

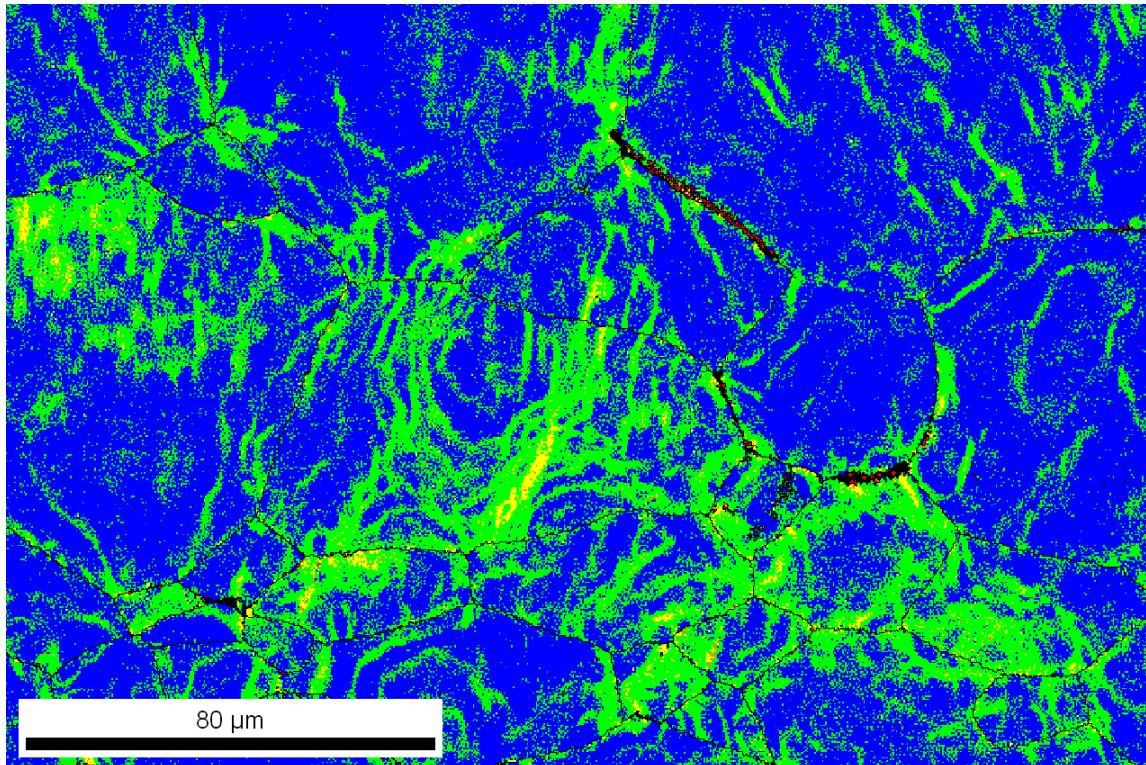

Color Coded Map Type: Kernel Average Misorientation

	Min	Max	Total Fraction	Partition Fraction
Blue	0	0.7	0.669	0.669
Green	0.7	1.4	0.311	0.311
Yellow	1.4	2.1	0.013	0.013
Orange	2.1	2.8	0.001	0.001
Red	2.8	3.5	0.002	0.002

Boundaries: Rotation Angle

	Min	Max	Fraction	Number	Length
—	15°	180°	0.011	8093	2.43 mm

\*For statistics - any point pair with misorientation exceeding 0° is considered a boundary  
total number = 743433, total length = 22.30 cm)

Stored Strain Energy

KAM 3<sup>rd</sup> neighbor x 0.3  $\mu\text{m}$  spatial resolution

# Nb: EBSD GROD Map 500 $\mu\text{m}$ deep

Severely deformed,  $>15^\circ$  in 50  $\mu\text{m}$

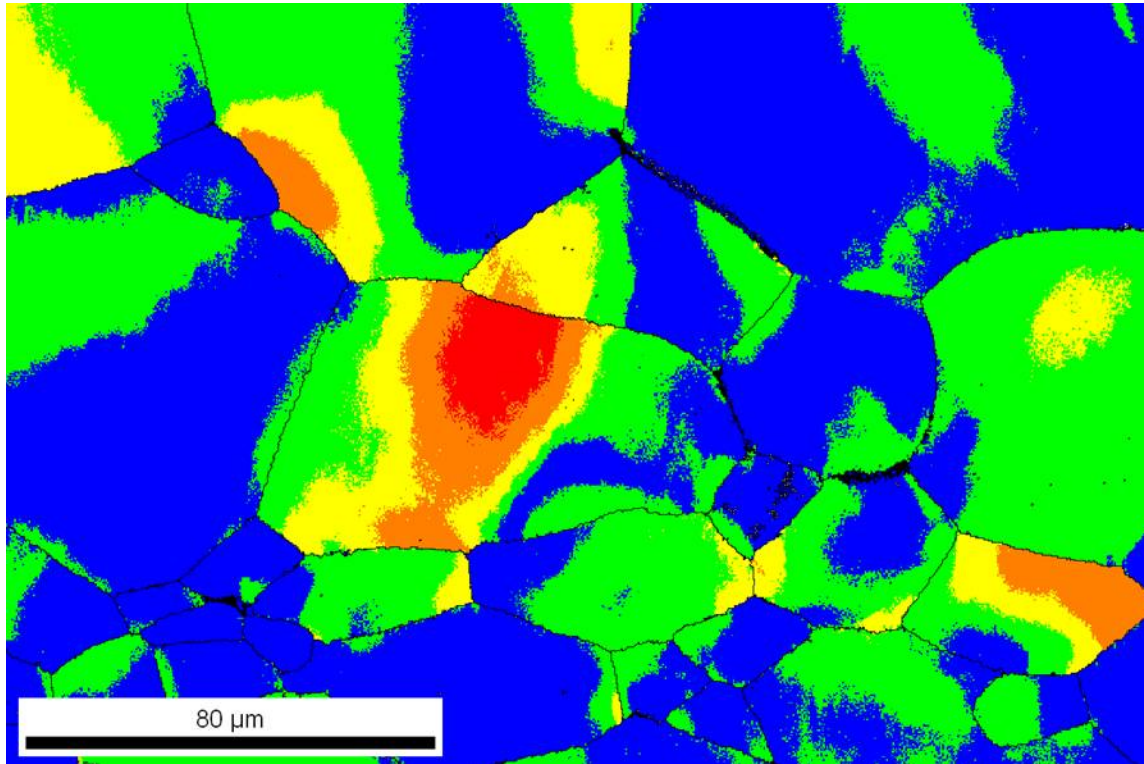

Color Coded Map Type: Grain Reference Orientation Deviation

	Min	Max	Total Fraction	Partition Fraction
Blue	0	3.87436	0.488	0.488
Green	3.87436	7.74872	0.369	0.369
Yellow	7.74872	11.6231	0.088	0.088
Orange	11.6231	15.4974	0.038	0.038
Red	15.4974	19.3718	0.013	0.013

Boundaries: Rotation Angle

	Min	Max	Fraction	Number	Length
—	15°	180°	0.011	8093	2.43 mm

\*For statistics - any point pair with misorientation exceeding 0° is considered a boundary  
total number = 743433, total length = 22.30 cm)

Deviation from grain minimum KAM

# Nb: Backscattered electron image

---

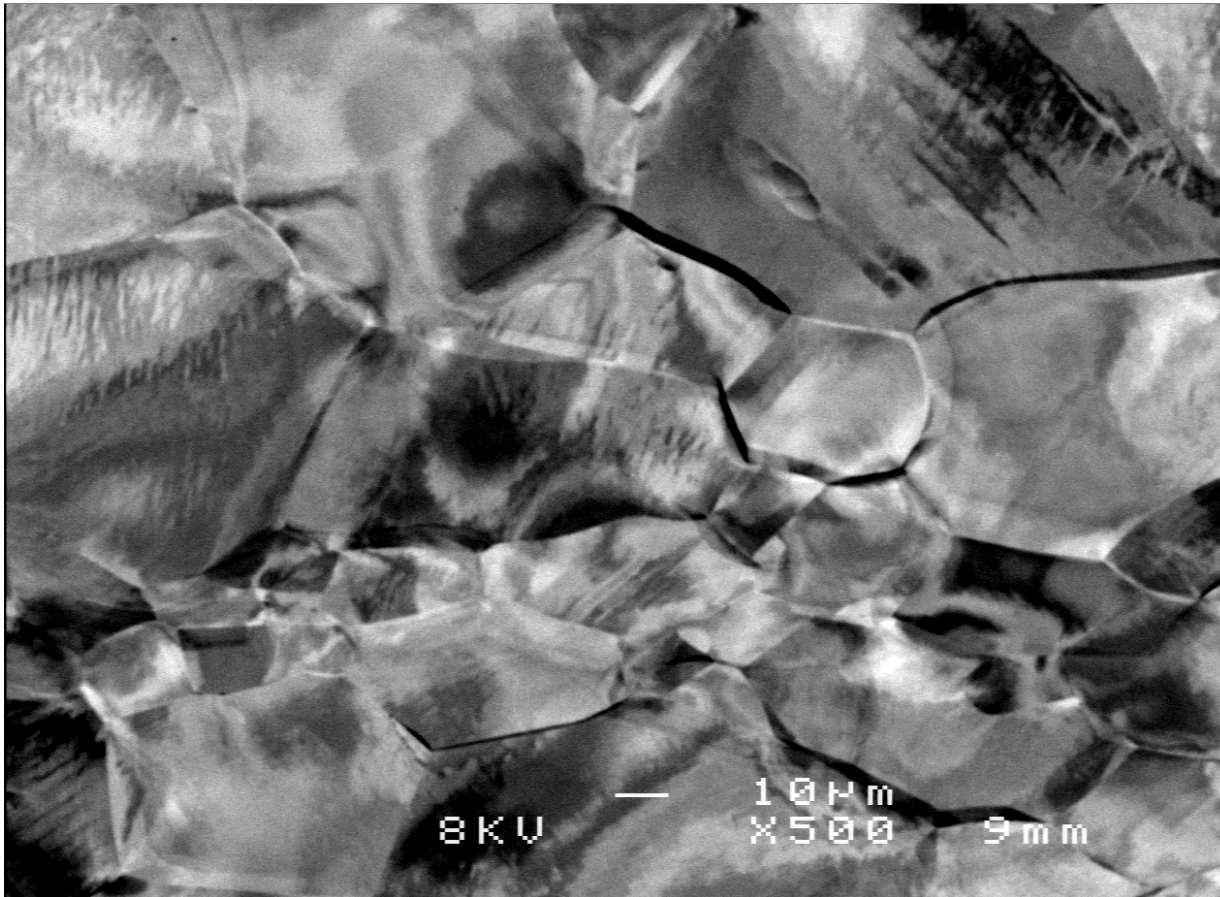

Channeling contrast of Polished and etched surface resembles EBSD map

In as-deep-drawn condition, severe strain located in pockets through-thickness.

Greater strain at 300 and 500  $\mu\text{m}$  than at surface.

# Reconstructed Boundaries

- The software includes an analysis of grain boundaries that outputs the information as a (long) list of line segment data.
- Data MUST be on hexagonal grid
- use of the GB segment analysis is an essential preliminary step before performing the stereological 5-parameter analysis of GBCD.
- Clear up the data to desired level
- The data must be on a hexagonal/triangular grid. If you have a map on a square grid, you must convert it to a hexagonal grid. Use the software called OIMTools to do this (freely available fortran program).
- This type of data is required for stereological analysis of 5-parameter grain boundary character

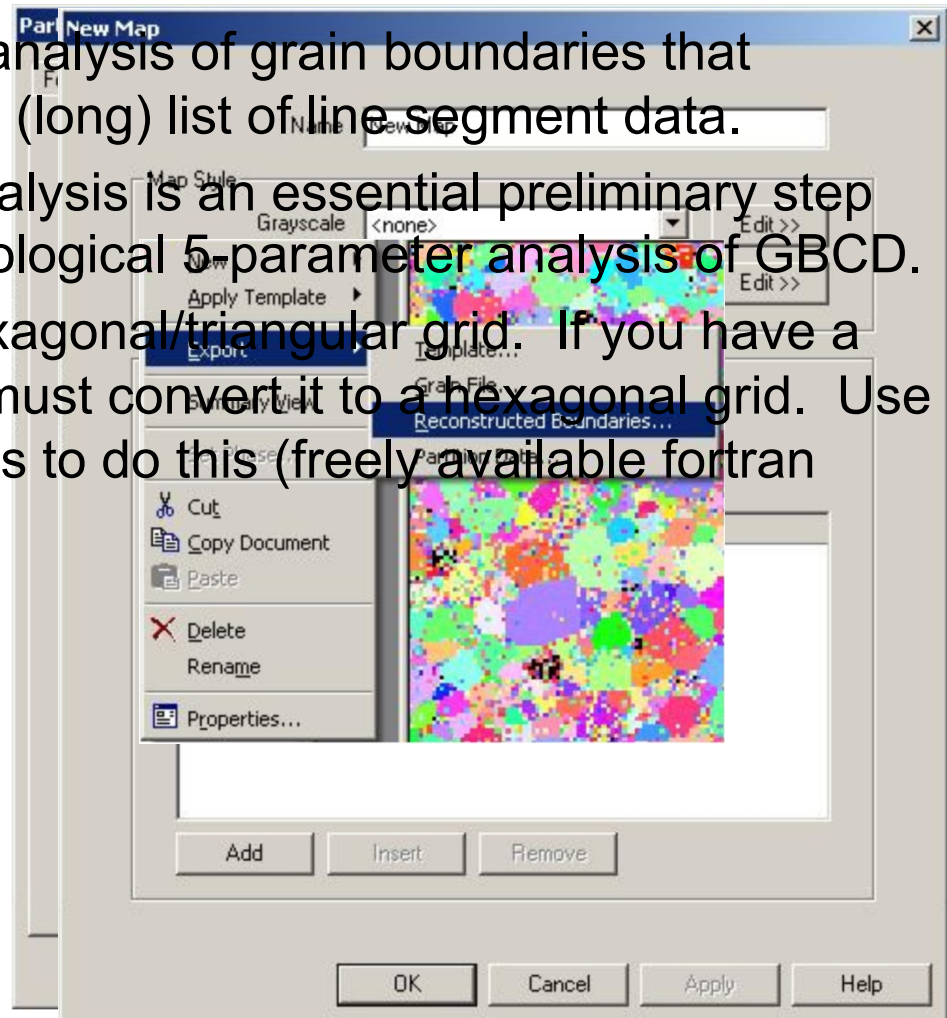

# Geometrically Necessary Dislocations (GND)

---

- Orientation gradients in (crystalline) metals and ceramics can be accommodated in various ways.
    1. Elastic distortions of the lattice
    2. Arrays of dislocations
    3. Grain boundaries (high angle)
    4. Disclinations
  - Ceramics rarely exhibit orientation gradients because they are difficult to deform plastically (high Peierls stress).
  - Elastic distortions are likely to be extremely small in metals because of the low resistance to dislocation motion, generally speaking.
  - Dislocation arrays are how orientation gradients are produced within grains. This dislocation content is known as the Geometrically Necessary Dislocation density (GND) and represents a lower bound on the dislocation density. Statistically stored dislocations are considered to be unobservable at the scale of EBSD. GND is created during the plastic deformation of metals.
  - High angle grain boundaries with atomically disordered interface structures also accommodate orientation gradients (in the sense of a sharp interface limit).
  - Disclinations are an alternative approach to accommodating orientation gradients. They are more controversial because there are very few direct observations of disclinations, by contrast to lattice dislocations.
-

# GND, contd.

---

- We now address the analysis of GND.
- There is a tensor known as the dislocation tensor or Nye's tensor,  $\alpha$ .

$$\alpha_{ij} = e_{ikl} \left( \varepsilon_{jl,k}^e + g_{jl,k} \right)$$

- Here,  $\varepsilon^e$  is the elastic strain tensor and  $g$  is the lattice orientation expressed as an orientation matrix in the usual fashion. In the absence of long-range elastic stress fields, Nye's original formulation of the dislocation tensor is obtained:

$$\alpha_{ij} = e_{ikl} g_{jl,k}$$

- The dislocation tensor can thus be directly calculated from the observable, i.e. the gradient of the orientation field. We can also write:  $\alpha = \text{curl}(\mathbf{g})$

---

J.F. Nye, "Some geometrical relations in dislocated crystals" *Acta Metall.*, **1**, 153 (1953).

El-Dasher *et al.*, 2003. "Viewpoint: experimental recovery of geometrically necessary dislocation density in polycrystals" *Scripta mater.* **48**, 141.

# Nye tensor to GND content

---

- Nye's original work also shows a precise connection between the dislocation tensor and the local dislocation network, formally expressed as:

$$\alpha_{ij} = \sum_{k=1}^K \rho^k b_i^k \hat{z}_j^k$$

- Here,  $\rho$  is the dislocation density of the  $k^{\text{th}}$  dislocation type,  $b$  is the associated Burgers vector and  $z$  is the corresponding line direction. There are 1 through  $K$  dislocations types.
  - It is typical to make the line direction discrete, i.e. either edge (perpendicular to the Burgers vector) or screw type (parallel to  $b$ ). In fcc metals with 6 distinct  $\langle 110 \rangle$  Burgers vectors, this gives 18 dislocation types because each  $\langle 110 \rangle$  edge can exist on two different slip planes.
  - The analytical challenge is, therefore, the undetermined nature of the equation because there are more free variables on the RHS than (derived) observables on the LHS. Generally speaking, numerical methods such as simplex must be resorted to, combined with a constraint such as minimization of the total dislocation line length.
-



# Disclination analysis

---

- Analyzing orientation gradients in terms of disclinations has been known for many years.
  - Disclinations can be thought of as wedges on a continuum basis. Isolated disclinations have divergent strain fields but disclination dipoles are similar (but not the same as) arrays of edge dislocations.
  - Disclination analysis has been developed by a number of people such as Romanov; most recently Fressengeas and Capolungo.
-

# Disclinations, analysis

---

- To make a start, consider the gradient of the displacement field, formally the distortion tensor and equivalent to strain.

$$U = \text{grad}(u)$$

- Consider the incompatible elastic distortion of the lattice that arises to maintain lattice continuity. The *curl* of this tensor provides the same Nye tensor as before.

$$\alpha = \text{curl}(U_e^\perp) \approx \text{curl}(g)$$

- There is a similar equation for the disclination density,  $\theta$ , based on the curl of the elastic curvature,  $\kappa_e$ :

$$\theta = \text{curl}(\kappa_e)$$

- The tricky part is how to obtain the elastic curvature from the observable, i.e. the orientation field,  $g$ . Here,  $\omega_e$  is the rotation vector, obtained from the misorientation rotation matrix,  $\Delta g$ .

$$\kappa_e = \text{grad}(\vec{\omega}_e); \vec{\omega}_i^e = -e_{ijk} \Delta g_{jk}; \text{ thus } \kappa_{ij}^e \approx \Delta \omega_i / \Delta x_j; \theta_{ij} \approx e_{jkl} \Delta \omega_i / \Delta x_l / \Delta x_k$$

---

# Disclinations, analysis, contd.

---

- It is useful to note that one can always compute the Nye tensor and fit a dislocation density to this value at each point. The curl of the curvature tensor,  $\kappa_e$ , which is the disclination vector, is assumed to be zero for this. If this field is non-zero, then a disclination field is present. This disclination field can be regarded as a quantification of the rotation defects present in the material.
  - Recent papers on this topic include these:
    - M. Upadhyay, L. Capolungo, V. Taupin, C. Fressengeas, “Grain boundary and triple junction energies in crystalline media: A disclination based approach”, *International Journal of Solids and Structures* **48** (2011) 3176–3193
    - C. Fressengeas, V. Taupin, M. Upadhyay, L. Capolungo, “Tangential continuity of elastic/plastic curvature and strain at interfaces”, *International Journal of Solids and Structures* **49** (2012) 2660–2667
-