

Polycrystal Plasticity - Multiple Slip

27-750

Texture, Microstructure & Anisotropy

A.D. Rollett,

Lecture notes originally by:

H. Garmestani (GaTech),

G. Branco (FAMU/FSU)

Last revised: 23rd Feb. 2016



Objective

- The objective of this lecture is to show how plastic deformation in polycrystals requires *multiple slip* in each grain. This is commonly referred to as the “Taylor model” in the literature.
- Further, to show how to calculate the distribution of slips in each grain of a polycrystal (principles of operation of **Los Alamos polycrystal plasticity, LApp**; also the **Viscoplastic Selfconsistent** code, **VPSC**; also “crystal plasticity” simulations in general).

Requirements:

- Dislocation controlled plastic strain
- Mechanics of Materials, or, micro-mechanics
- Continuum Mechanics

Questions

- What are the key aspects of the Taylor model?
- What is the difference between single slip and multiple slip in terms of boundary conditions?
- What is “deviatoric stress” and why does it have 5 components?
- How does the von Mises criterion for ductility relate to the 5 components of deviatoric stress and strain?
- How does the Bishop-Hill theory work? What is the input and output to the algorithm? What is meant by the “maximum work” principle?
- What is the Taylor factor (both definition and physical meaning)?
- Why is the rate-sensitive formulation for multiple slip useful above and beyond what the Bishop-Hill approach gives?
- What is it that causes/controls texture development?
- On what quantities is lattice reorientation based (during multiple slip)?
- How can we compute the macroscopic strain due to any given slip system?
- How can we compute the resolved shear stress on a given slip system, starting with the macroscopic stress (tensor)?
- What does Bishop & Hill state of stress mean (what is the physical meaning)? [Each B&H stress state (one of the 28) corresponds to a corner of the single xtal yield surface that activates either 6 or 8 slip systems simultaneously]

References

- Key Papers:
 1. Taylor G (1938) "Plastic strain in metals", *J. Inst. Metals* (U.K.) **62** 307 ;
 2. Bishop J and Hill R (1951), *Phil. Mag.* **42** 1298;
 3. Van Houtte P (1988), *Textures and Microstructures* **8 & 9** 313-350;
 4. Lebensohn RA and Tome CN (1993) "A Self-Consistent Anisotropic Approach for the Simulation of Plastic-Deformation and Texture Development of Polycrystals - Application to Zirconium Alloys" *Acta Metall. Mater.* **41** 2611-2624.
- Kocks, Tomé & Wenk: *Texture & Anisotropy* (Cambridge); chapter 8, 1996. Detailed analysis of plastic deformation and texture development.
- Reid: *Deformation Geometry for Materials Scientists*, 1973. Older text with many nice worked examples. Be careful of his examples of calculation of Taylor factor because, like Bunge & others, he does not use von Mises equivalent stress/strain to obtain a scalar value from a multiaxial stress/strain state.
- Hosford: *The Mechanics of Crystals and Textured Polycrystals*, Oxford, 1993. Written from the perspective of a mechanical metallurgist with decades of experimental and analytical experience in the area.
- Khan & Huang: *Continuum Theory of Plasticity*, Wiley-Interscience, 1995. Written from the perspective of continuum mechanics.
- De Souza Neto, Peric & Owen: *Computational Methods for Plasticity*, 2008 (Wiley). Written from the perspective of continuum mechanics.
- Gurtin: *An Introduction to Continuum Mechanics*, ISBN 0123097509, Academic Press, 1981.

Background, Concepts

Increasing strain

Output of Lapp*

- Figure shows pole figures for a simulation of the development of rolling texture in an fcc metal.
- Top = 0.25 von Mises equivalent strain; 0.50, 0.75, 1.50 (bottom).
- Note the increasing texture strength as the strain level increases.

*Lapp = Los Alamos polycrystal plasticity (code)

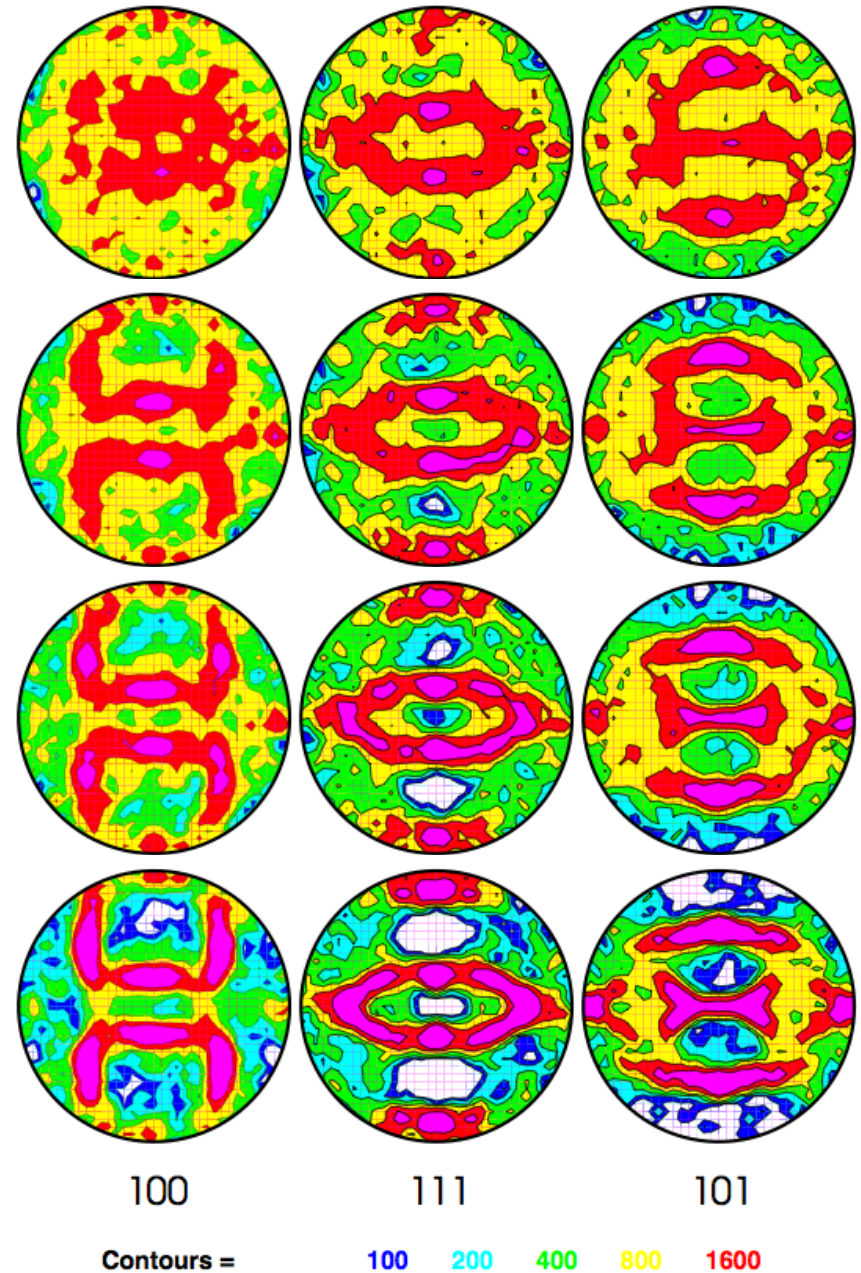

Development

The Theory depends upon:

- The physics of single crystal plastic deformation;
- relations between macroscopic and microscopic quantities (strain, stress ...);

The mathematical representation and models

- ❑ Initially proposed by Sachs (1928), Cox and Sopwith (1937), and **Taylor in 1938**. Elaborated by **Bishop and Hill (1951)**, Kocks (1970), Asaro & Needleman (1985), Canova (1984).
- ❑ Self-Consistent model by Kröner (1958, 1961), extended by Budiansky and Wu (1962).
- ❑ Further developments by Hill (1965a,b) and Lin (1966, 1974, 1984) and others.

- Read Taylor (1938) “Plastic strain in metals.” *J. Inst. Metals (U.K.)* **62**, 307; available as: Taylor_1938.pdf

Sachs versus Taylor

Sachs Model (previous lecture on single crystal):

- All single-crystal grains with aggregate or polycrystal experience the same state of stress;
- Equilibrium condition across the grain boundaries satisfied;
- Compatibility conditions between the grains violated, thus, finite strains will lead to gaps and overlaps between grains;
- Generally most successful for single crystal deformation with *stress boundary conditions on each grain*.



Taylor Model (this lecture):

- All single-crystal grains within the aggregate experience the same state of deformation (strain);
- Equilibrium condition across the grain boundaries violated, because the vertex stress states required to activate multiple slip in each grain vary from grain to grain;
- Compatibility conditions between the grains satisfied;
- Generally most successful for polycrystals with *strain boundary conditions on each grain*.

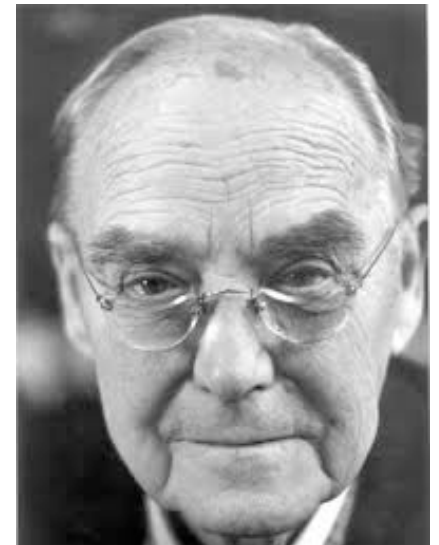

Sachs versus Taylor: 2

- Diagrams illustrate the difference between the Sachs iso-stress assumption of single slip in each grain (a, c and e) versus the Taylor assumption of iso-strain with multiple slip in each grain (b, d).

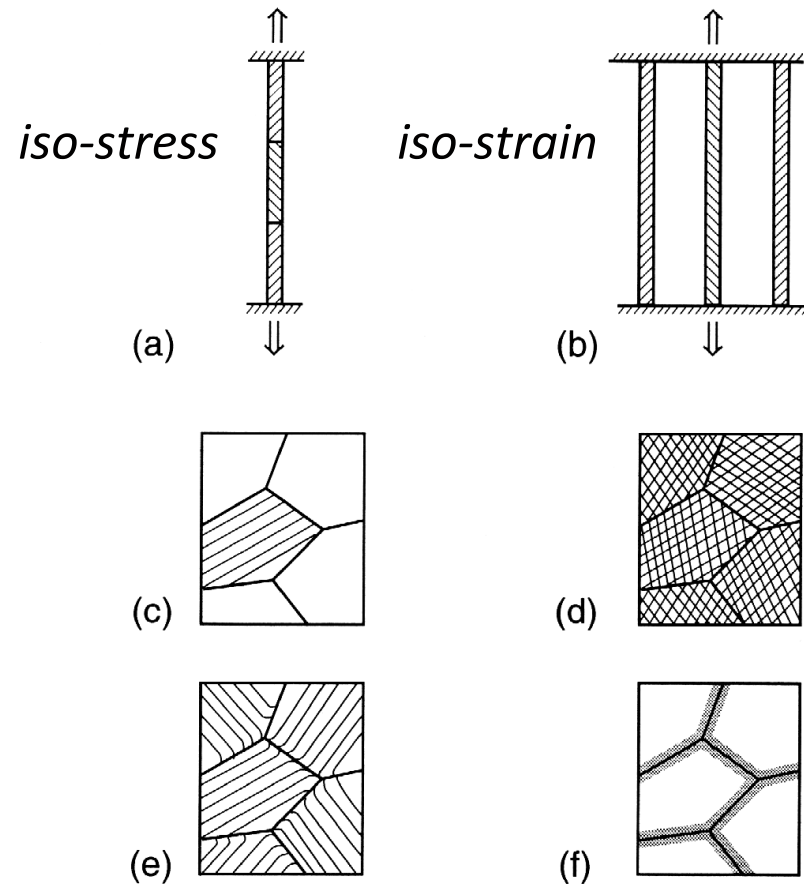

Fig. 23. Schematic description of various polycrystal plasticity models: (a) a true lower bound for a linear serial polycrystal; (b) the Sachs model (independent parallel grains); (c) a true lower bound for a 3-D polycrystal (only one grain deforms at any instant); (d) a true upper bound (also the Taylor model); (e) the Kochendörfer model (single slip plus bending); (f) the Ashby model (polyslip plus 'geometrically necessary dislocations').

Sachs versus Taylor: 3

Single *versus* Multiple Slip

External Stress

or

External Strain

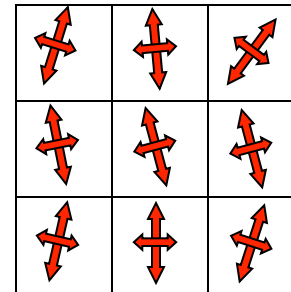
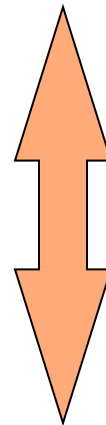
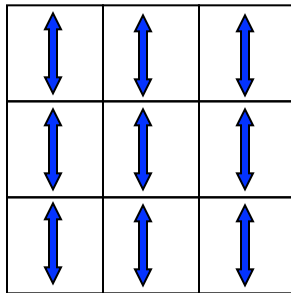

Small **arrows** indicate variable stress state in each grain

Increasing strain

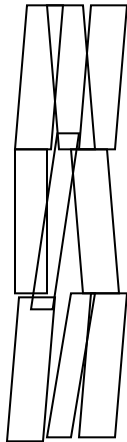

Small **arrows** indicate identical stress state in each grain

Each grain deforms according to which **single slip** system is active (based on Schmid factor)

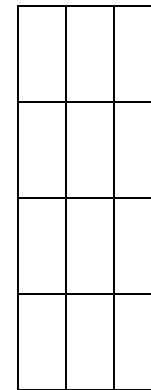

Multiple slip (with 5 or more systems) in each grain satisfies the externally imposed **strain, D**

$$D = E^T d\gamma$$

$$\frac{\sigma}{\tau} = \frac{\dot{\gamma}}{\dot{\epsilon}} = \frac{1}{\cos \lambda \cos \phi}$$

$$D^C = \dot{\epsilon}_0 \sum_s \left| \frac{m^{(s)} : \sigma^c}{\tau^{(s)}} \right|^{n^{(s)}} m^{(s)} \operatorname{sgn}(m^{(s)} : \sigma^c)$$

Taylor model: uniform strain

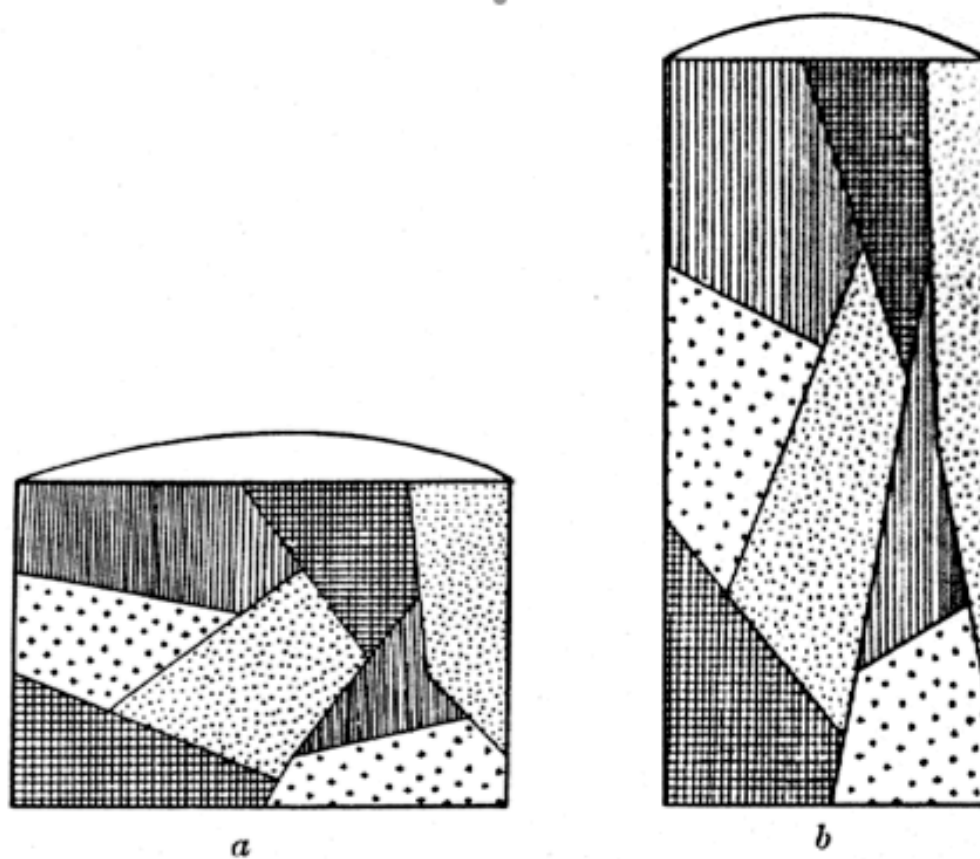
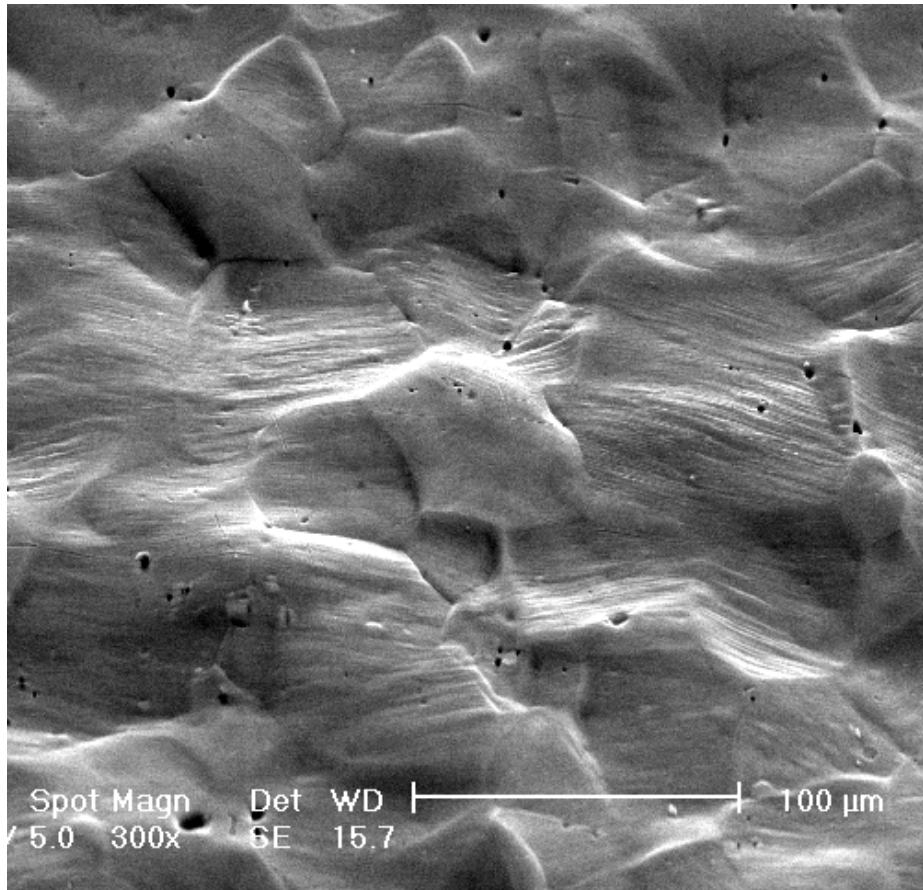

FIG. 12.—Crystal Aggregate : *a*, Unstrained ; *b*, After 125 Per Cent. Extension.

An essential assumption of the Taylor model is that each grain conforms to the macroscopic strain imposed on the polycrystal

Example of Slip Lines at Surface (plane strain stretched Al 6022)

T-Sample at 15% strain



PD // TD

PSD // RD

- Note how each grain exhibits varying degrees of slip line markings.
- Although any given grain has one dominant slip line (trace of a slip plane), more than one is generally present.
- Taken from CMU PhD research of Yoon-Suk Choi (Pusan U) on surface roughness development in Al 6022

Notation: 1

- Strain, local: E^{local} ; global: E^{global}
- Slip direction (unit vector): \mathbf{b} or \mathbf{s}
- Slip plane (unit) normal: \mathbf{n}
- Slip, or Schmid tensor, $m_{ij} = b_i n_j = P_{ij}$
- Stress (tensor or vector): σ
- Shear stress (usually on a slip system): τ
- Shear strain (usually on a slip system): γ
- Stress deviator (tensor): S
- Rate sensitivity exponent: n
- Slip system index: s or α
- Note that when an index (e.g. of a Slip system, $b^{(s)}n^{(s)}$) is enclosed in parentheses, it means that the summation convention does not apply even if the index is repeated in the equation.

Notation: 2

- Coordinates: current: x ; reference X
- Velocity of a point: v .
- Displacement: u
- Hardening coefficient: h ($d\sigma = h d\gamma$)
- Strain, ε
 - ◆ measures the change in shape
- Work increment: dW
 - ◆ do not confuse with *lattice spin*!
- Infinitesimal rotation tensor: Ω
- Elastic Stiffness Tensor (4th rank): C
- Load, e.g. on a tensile sample: P
 - do not confuse with *slip tensor*!

Notation: 3

- Plastic spin: W
 - ◆ measures the rotation rate; more than one kind of spin is used:
 - ◆ “Rigid body” spin of the whole polycrystal: W
 - ◆ “grain spin” of the grain axes (e.g. in torsion): W^g
 - ◆ “lattice spin” from slip/twinning (skew symmetric part of the strain): W^c .
- Rotation (small): ω

Notation: 4

- Deformation gradient: F

$$F_{ij} = \frac{\partial x_i}{\partial X_j}$$
 - ◆ Measures the total change in shape (rotations included).

- Velocity gradient: L
 - ◆ Tensor, measures the rate of change of the deformation gradient

- Time: t

- Slip geometry matrix: E (do not confuse with strain)

- Strain rate: $D \equiv \dot{\epsilon} \equiv \frac{d\epsilon}{dt}$
 - ◆ symmetric tensor; $D = \text{symm}(L)$

Basic Equations

Sachs model: iso-stress:

Identify the index, s , of the active system(s) from k available systems from the maximum Schmid factor: $\max_s(\mathbf{b}^{(s)} \sigma \mathbf{n}^{(s)})$.

If strain is accumulated compute the slip (shear strain) from the macroscopic applied strain. If more than one system is active (e.g. primary+conjugate) divide the shear strains equally.

Taylor model: iso-strain (Bishop & Hill variant for fcc/bcc only):

Identify the index, r , active (multi-slip) stress state (from list of 28) from the maximum inner product between the vertex stress state and the applied strain: $\max_r(\sigma^{(r)} d\varepsilon)$.

Each possible vertex stress state activates 6 or 8 slip systems; either make an arbitrary choice of 5 to satisfy the external slip or, more typically compute the solution to the "rate-sensitive slip equation", below, i.e. the stress that satisfies the imposed strain rate. The slip rate on the s^{th} system is given by the exponentiated expression. Lattice spin is computed from the skew-symmetric version of the same expression.

$$D^C = \dot{\varepsilon}_0 \sum_s \left| \frac{m^{(s)} : \sigma^c}{\tau^{(s)}} \right|^{n^{(s)}} m^{(s)} \operatorname{sgn}(m^{(s)} : \sigma^c)$$

Dislocations, Slip Systems, Crystallography

- This section is provided to remind students about the basic geometry of slip via dislocation glide. Full details can, of course, be found in standard textbooks.

Dislocations and Plastic Flow

- ❑ At room temperature the dominant mechanism of plastic deformation is dislocation motion through the crystal lattice.
- ❑ Dislocation glide occurs on certain *crystal planes (slip planes)* in certain *crystallographic directions (// Burgers vector)*.
- ❑ A *slip system* is a combination of a slip direction and slip plane normal.
- ❑ A second-rank tensor ($m_{ij} = b_i n_j$) can be associated with each slip system, formed from the outer product of slip direction and normal. The resolved shear stress on a slip system is then given by the inner product of the Schmid and the stress tensors: $\tau = m_{ij} \sigma_{ij}$
- ❑ The crystal structure of metals is not altered by the plastic flow because slip is a *simple shear* mode of deformation. Moreover no volume change is associated with slip, therefore the hydrostatic stress has no effect on plasticity (in the absence of voids and/or dilatational strain). This explains the use of *deviatoric stress* in calculations.

Crystallography of Slip

Slip occurs most readily in specific directions on certain crystallographic planes.

Slip plane – is the plane of greatest atomic density.

Slip direction – is the close-packed direction within the slip plane.

Slip system – is the combination of preferred slip planes and slip directions (on those specific planes) along which dislocation motion occurs. Slip systems are dependent on the crystal structure.

Crystallography of Slip in fcc

Example: Determine the slip system for the (111) plane in a fcc crystal and sketch the result.

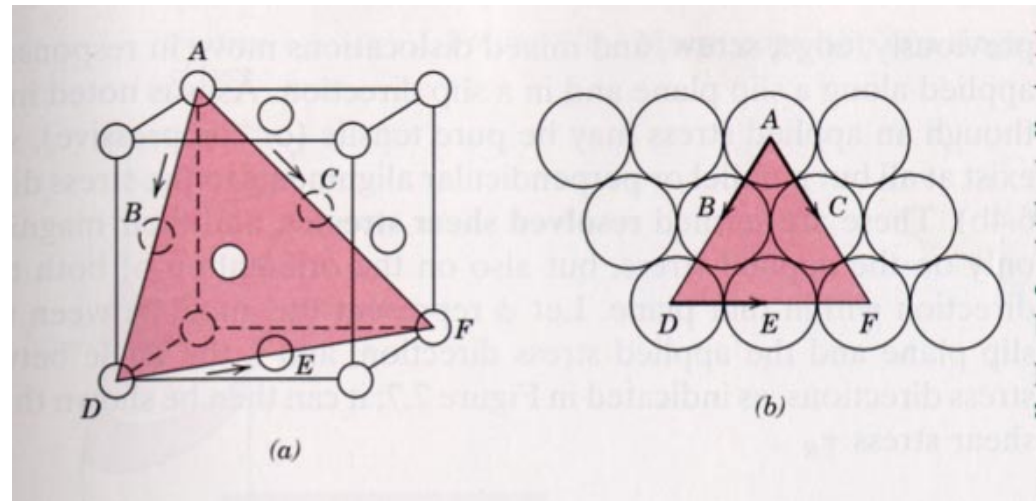
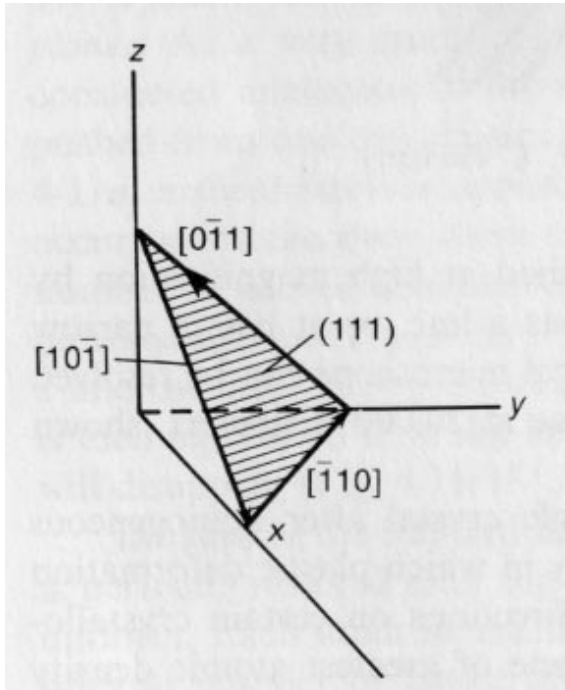

The slip direction in *fcc* is $\langle 110 \rangle$

The proof that a slip direction $[uvw]$ lies in the slip plane (hkl) is given by calculating the scalar product:

$$hu + kv + lw = 0$$

Slip Systems in Hexagonal Metals

Basal
 $(0002) \langle 2 -1 -1 0 \rangle$

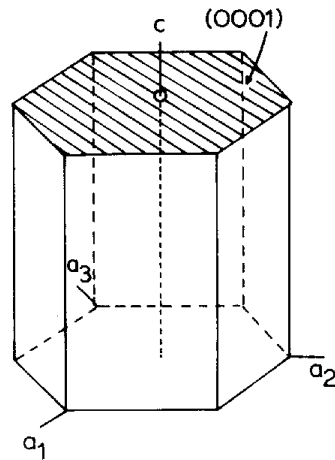

Prism
 $\{0 -1 1 0\} \langle 2 -1 -1 0 \rangle$
 Also:
 $(2 -1 -1 0)$

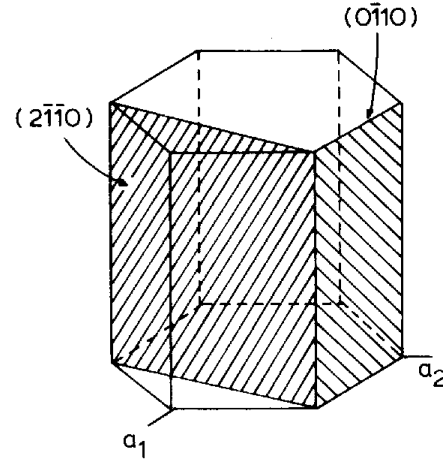

Pyramidal (c+a)
 $(1 0 -1 1) \langle 1 -2 1 3 \rangle$
 Pyramidal (a)
 $(1 0 -1 1) \langle 1 -2 1 0 \rangle$

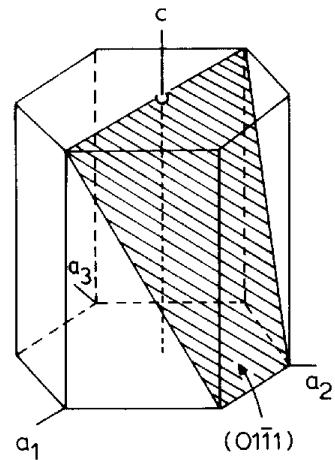

Pyramidal
 $(1 0 -1 2)$

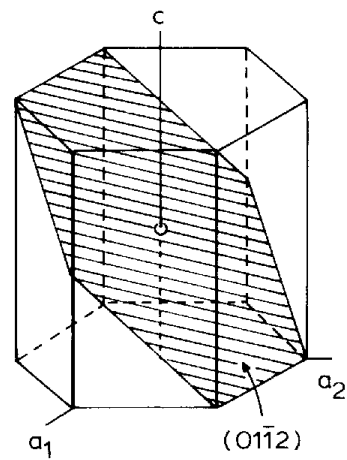

FIG. IV-5—Some important planes in the hcp system and their Miller-Bravais indices.

Slip Systems in fcc, bcc, hexagonal

The slip systems for FCC, BCC and hexagonal crystals are:

<i>Metals</i>	<i>Slip Plane</i>	<i>Slip Direction</i>	<i>Number of Slip Systems</i>
Face-Centered Cubic			
Cu, Al, Ni, Ag, Au	{111}	$\langle 1\bar{1}0 \rangle$	12
Body-Centered Cubic			
α -Fe, W, Mo	{110}	$\langle \bar{1}11 \rangle$	12
α -Fe, W	{211}	$\langle \bar{1}11 \rangle$	12
α -Fe, K	{321}	$\langle \bar{1}11 \rangle$	24
Hexagonal Close-Packed			
Cd, Zn, Mg, Ti, Be	{0001}	$\langle 11\bar{2}0 \rangle$	3
Ti, Mg, Zr	{10 $\bar{1}$ 0}	$\langle 11\bar{2}0 \rangle$	3
Ti, Mg	{10 $\bar{1}$ 1}	$\langle 11\bar{2}0 \rangle$	6

Also: Pyramidal (c+a) (1 0 -1 1) $\langle 1 -2 1 3 \rangle$

For this lecture we will focus on FCC crystals only

Note: In the case of FCC crystals we can see in the table that there are 12 slip systems. However if forward and reverse systems are treated as independent, there are then 24 slip systems.

Schmid / Sachs / Single Slip

- This section is included as a reminder of how to analyze single slip. Since it assumes stress boundary conditions the analysis is straightforward. More detail is provided in the lecture that explicitly addresses this topic.

Schmid Law

- ❑ Initial yield stress varies from sample to sample depending on, among several factors, the relation between the crystal lattice to the loading axis (i.e. *orientation*, written as g).
- ❑ The applied stress resolved along the slip direction on the slip plane (to give a shear stress) initiates and controls the extent of plastic deformation.
- ❑ Yield begins on a given slip system when the shear stress on this system reaches a critical value, called the *critical resolved shear stress* (τ_{crss}), independent of the tensile stress or any other normal stress on the lattice plane (in less symmetric lattices, however, there may be some dependence on the hydrostatic stress).
- ❑ The magnitude of the yield stress depends on the density and arrangement of obstacles to dislocation flow, such as precipitates (not discussed here).

Minimum Work, Single Slip (Sachs)

Under stress boundary conditions, *single slip* occurs

Uniaxial Tension or Compression
(where “**m**” is the slip tensor):

$$\dot{\epsilon} = \mathbf{m}\dot{\gamma}$$

The (dislocation) slip is given by
(where “**m**” is the Schmid factor):

$$\dot{\gamma} = \frac{\dot{\epsilon}}{\cos \lambda \cos \phi} = \frac{\dot{\epsilon}}{m}$$

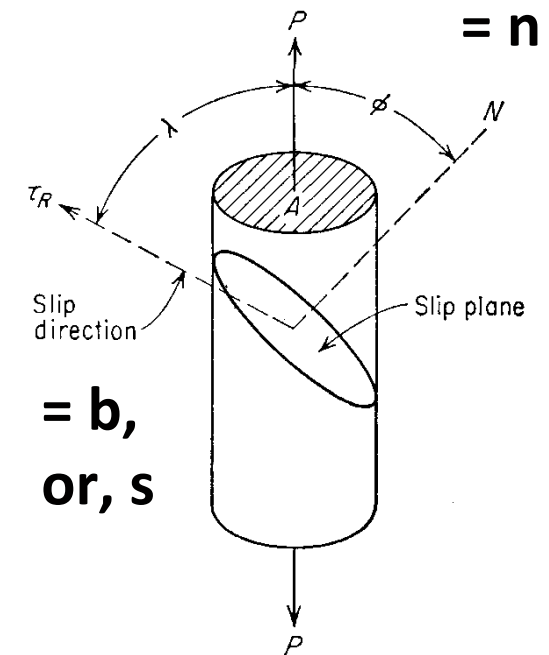

P is a *unit vector* in the loading direction

This slide, and the next one, are a re-cap of the lecture on single slip

Minimum Work, Single Slip

Applying the *Minimum Work Principle*, it follows that

$$\frac{\sigma}{\tau} = \frac{\dot{\gamma}}{\dot{\epsilon}} = \frac{1}{\cos \lambda \cos \phi} = \frac{1}{m}$$

$$\sigma = \frac{\tau(\gamma)}{m} = \frac{\tau(\epsilon/m)}{m}$$

Note: $\tau(\gamma)$ describes the dependence of the critical resolved shear stress (*crss*) on strain (or slip curve), based on the idea that the *crss* increases with increasing strain. The *Schmid factor*, m , has a maximum value of 0.5 (both angles = 45°).

If finite strain is imposed, the shear strain (slip) increment is given by the macroscopic strain divided by the Schmid factor,
 $d\gamma = d\epsilon \div m$. After each increment, the Schmid factor must be recalculated because the lattice orientation has changed (in relation to the tensile stress axis)

Elastic vs. Plastic Deformation

Selection of Slip Systems for Rigid-Plastic Models

Assumption – For fully plastic deformation, the elastic deformation rate is usually small when compared to the plastic deformation rate and thus it can be neglected.

Reasons:

The elastic strain is limited to the ratio of stress to elastic modulus

Perfect plastic materials - equivalent stress = initial yield stress

For most metals, the initial yield stress is 2 to 4 orders of magnitude less than the elastic modulus – ratio is $\ll 1$

Macro Strain – Micro Slip

Selection of Slip Systems for Rigid-Plastic Models

Once the elastic deformation rate is considered, it is reasonable to model the material behavior using the rigid-plastic model. The plastic strain rate is given by the sum of the slipping rates multiplied by their Schmid tensors:

$$D = D^p = \sum_{\alpha=1}^n m_{\alpha} \dot{\gamma}_{\alpha}$$

$$P_{\alpha} = b_{\alpha} \otimes n_{\alpha}$$

$$P_{ij}^{(\alpha)} = b_i^{(\alpha)} n_j^{(\alpha)}$$

$$m_{ij}^{(\alpha)} = b_i^{(\alpha)} n_j^{(\alpha)}$$

where

n is \leq to 12 systems (or 24 systems – forward and reverse considered independent)

Note: D can be expressed by six components (Symmetric Tensor)
Because of the incompressibility condition – $\text{tr}(D) = D_{ii} = 0$,
only five out of the six components are independent.

Von Mises criterion

Selection of Slip Systems for Rigid Plasticity Models

As a consequence of the condition

$$\text{tr}(\mathbf{D}) = D_{ii} = 0$$

the number of possible active slip systems (in cubic metals) is greater than the number of independent components of the tensor strain rate D^p , from the mathematical point of view (under-determined system), so any combination of five slip systems that satisfy the incompressibility condition can allow the prescribed deformation to take place. The requirement that *at least five independent systems are required for plastic deformation* is known as the *von Mises Criterion*. If less than 5 independent slip systems are available, the ductility is predicted to be low in the material. The reason is that each grain will not be able to deform with the body and gaps will open up, i.e. it will crack. Caution: even if a material has 5 or more independent systems, it may still be brittle (e.g. Iridium).

*Selection of Active Slip Systems:
Taylor's Minimum Work Principle*

Minimum Work Principle

- ❖ Proposed by Taylor in (1938).
- ❖ The objective is to determine the combination of shears or slips that will occur when a prescribed strain is produced.
- ❖ States that, of all possible combinations of the 12 shears that can produce the assigned strain, only that combination for which the energy dissipation is the least is operative.
- ❖ The defect in the approach is that it says nothing about the activity or resolved stress on other, non-active systems (This last point was addressed by Bishop and Hill in 1951).

Mathematical
statement:

$$\sum_{\alpha=1}^n \tau_c \dot{\gamma}_\alpha \leq \sum_{\alpha=1}^n \tau_\alpha^* \dot{\gamma}_\alpha^*$$

Minimum Work Principle

Minimum Work Principle

$$\sum_{\alpha=1}^n \tau_c \dot{\gamma}_\alpha \leq \sum_{\alpha=1}^n \tau_\alpha^* \dot{\gamma}_\alpha^*$$

Here,

$\dot{\gamma}_\alpha$ - are the actually activated slips that produce D.

$\dot{\gamma}_\alpha^*$ - is any set of slips that satisfy $tr(D)=D_{ii} = 0$, but are operated by the corresponding stress satisfying the loading/unloading criteria.

τ_c - is the (current) *critical resolved shear stress (crss)* for the material (applies on any of the α^{th} activated slip systems).

τ_α^* - is the current shear strength of (= resolved shear stress on) the α^{th} geometrically possible slip system that may not be compatible with the externally applied stress.

Minimum Work Principle

Recall that in the Taylor model all the slip systems are assumed to harden at the same rate, which means that

$$\tau_c = \tau_\alpha^*$$

and then,

$$\sum_{\alpha=1}^n |\dot{\gamma}^\alpha| \leq \sum_{\alpha=1}^n |\dot{\gamma}_\alpha^*|$$

Note that we now have only 12 operative slip systems once the forward and reverse shear strengths (crss) are considered to be the same in absolute value.

Minimum Work Principle

$$\sum_{\alpha=1}^n |\dot{\gamma}^{\alpha}| \leq \sum_{\alpha=1}^n |\dot{\gamma}_{\alpha}^{*}|$$

Thus Taylor's minimum work criterion can be summarized as in the following: **Of the possible 12 slip systems, only that combination for which the sum of the absolute values of shears is the least is the combination that is actually operative.**

The uniformity of the *crss* (same on all systems) means that the *minimum work* principle is equivalent to a *minimum microscopic shear* principle.

Stress > CRSS?

- The obvious question is, if we can find a set of microscopic shear rates that satisfy the imposed strain, how can we be sure that the shear stress on the other, inactive systems is not greater than the critical resolved shear stress?
- This is *not* the same question as that of equivalence between the minimum (microscopic) work principle and the maximum (macroscopic) work approach described later in this lecture.

Stress > CRSS?

- The *work increment* is the (inner) product of the stress and strain tensors, and must be the same, regardless of whether it is calculated from the macroscopic quantities or the microscopic quantities:

$$\delta w = \sigma_{ij} \delta \epsilon_{ij} = \tau_{\alpha} \delta \gamma_{\alpha}$$

For the actual set of shears in the material, we can write (omitting the “*”),

$$\delta w = \tau_{crss} \sum_{\alpha} \delta \gamma_{\alpha} = \tau_c \sum_{\alpha} \delta \gamma_{\alpha}$$

where the *crss* is outside the sum because it is constant.

Stress > CRSS?

- Now we know that the shear stresses on the hypothetical (denoted by “*”) set of systems must be less than or equal to the *crss*, τ_c , for all systems, so:

$$\tau_{\alpha}^* \leq \tau_c$$

This means that we can write:

$$\sum_{\alpha} \tau_{\alpha}^* \delta\gamma_{\alpha}^* \leq \tau_c \sum_{\alpha} \delta\gamma_{\alpha}^*$$

Stress > CRSS?

- However the LHS of this equation is equal to the work increment for any possible combination of slips, $\delta w = \sigma_{ij} \delta \varepsilon_{ij}$ which is equal to $\tau_c \sum_{\alpha} \delta \gamma_{\alpha}$, leaving us with:

$$\tau_c \sum_{\alpha} \delta \gamma_{\alpha} \leq \tau_c \sum_{\alpha} \delta \gamma_{\alpha}^*$$

So dividing both sides by τ_c allows us to write:

$$\sum_{\alpha} \delta \gamma \leq \sum_{\alpha} \delta \gamma^* \quad \text{Q.E.D.}$$

Multiple Slip

- This section analyzes the geometry of multiple slip, all in the crystal frame. This sets the scene for the treatment of the problem in terms of simultaneous equations.

Multiple Slip

General case – **D** }

- Deformation rate is multi-axial
- Only five independent (deviatoric) components

Crystal - FCC

Slip rates - $\dot{\gamma}_{a1}$, $\dot{\gamma}_{a2}$, $\dot{\gamma}_{a3}$,
on the slip systems a_1 , a_2 , a_3 ,
respectively.

Table 10.1 Designation of slip systems in FCC crystals

Plane	(111)			$(\bar{1}\bar{1}1)$		
Direction	$[0\bar{1}1]$	$[10\bar{1}]$	$[\bar{1}10]$	$[011]$	$[10\bar{1}]$	$[1\bar{1}0]$
System	a_1	a_2	a_3	b_1	b_2	b_3
Plane	$(\bar{1}11)$			$(1\bar{1}1)$		
Direction	$[0\bar{1}1]$	$[\bar{1}0\bar{1}]$	$[110]$	$[011]$	$[10\bar{1}]$	$[\bar{1}\bar{1}0]$
System	c_1	c_2	c_3	d_1	d_2	d_3

Note correction to system b_2

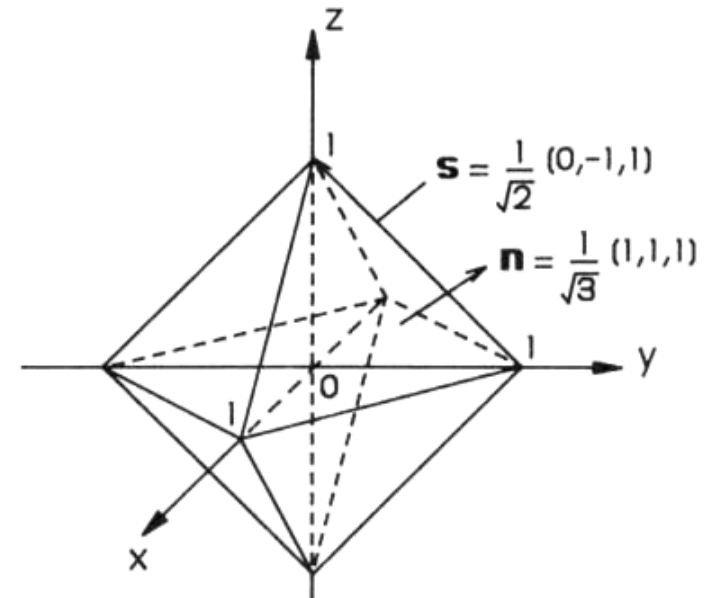

Fig. 11.1 Crystal axes and slip systems

Multiple Slip

Using

$$D = D^p = \sum_{\alpha=1}^n m_{\alpha} \dot{\gamma}_{\alpha}$$

the following set of relations can be obtained

$$2\sqrt{6}D_{xy} = 2\sqrt{6}e_x \cdot D \cdot e_y = -\dot{\gamma}_{a1} + \dot{\gamma}_{a2} - \dot{\gamma}_{b1} + \dot{\gamma}_{b2} + \dot{\gamma}_{c1} - \dot{\gamma}_{c2} + \dot{\gamma}_{d1} - \dot{\gamma}_{d2}$$

$$2\sqrt{6}D_{yz} = 2\sqrt{6}e_y \cdot D \cdot e_z = -\dot{\gamma}_{a2} + \dot{\gamma}_{a3} + \dot{\gamma}_{b2} - \dot{\gamma}_{b3} - \dot{\gamma}_{c2} + \dot{\gamma}_{c3} + \dot{\gamma}_{d2} - \dot{\gamma}_{d3}$$

$$2\sqrt{6}D_{zx} = 2\sqrt{6}e_z \cdot D \cdot e_x = -\dot{\gamma}_{a3} + \dot{\gamma}_{a1} + \dot{\gamma}_{b3} - \dot{\gamma}_{b1} + \dot{\gamma}_{c3} - \dot{\gamma}_{c1} - \dot{\gamma}_{d3} + \dot{\gamma}_{d1}$$

Note: e_x, e_y, e_z are unit vectors parallel to the axes

Multiple Slip

$$\begin{aligned}\sqrt{6}D_{xx} &= \sqrt{6}e_x \cdot D \cdot e_x \\ &= \dot{\gamma}_{a2} - \dot{\gamma}_{a3} + \dot{\gamma}_{b2} - \dot{\gamma}_{b3} + \dot{\gamma}_{c2} - \dot{\gamma}_{c3} + \dot{\gamma}_{d2} - \dot{\gamma}_{d3}\end{aligned}$$

$$\begin{aligned}\sqrt{6}D_{yy} &= \sqrt{6}e_y \cdot D \cdot e_y \\ &= \dot{\gamma}_{a3} - \dot{\gamma}_{a1} + \dot{\gamma}_{b3} - \dot{\gamma}_{b1} + \dot{\gamma}_{c3} - \dot{\gamma}_{c1} + \dot{\gamma}_{d3} - \dot{\gamma}_{d1}\end{aligned}$$

$$\begin{aligned}\sqrt{6}D_{zz} &= \sqrt{6}e_z \cdot D \cdot e_z \\ &= \dot{\gamma}_{a1} - \dot{\gamma}_{a2} + \dot{\gamma}_{b1} - \dot{\gamma}_{b2} + \dot{\gamma}_{c1} - \dot{\gamma}_{c2} + \dot{\gamma}_{d1} - \dot{\gamma}_{d2}\end{aligned}$$

Multiple Slip

To verify these relations, consider the contribution of shear on system c_3 as an example:

Given :

- Slip system - c_3 ; $\dot{\gamma}_{c_3}$
- Unit vector in the slip direction - $n = \frac{1}{\sqrt{3}}(-1, 1, 1)$
- Unit normal vector to the slip plane - $b = \frac{1}{\sqrt{2}}(1, 1, 0)$

The contribution of the c_3 system is given by:

$$\frac{1}{2}(bn + nb)\dot{\gamma}_{c_3} = \frac{\dot{\gamma}_{c_3}}{2\sqrt{6}} \begin{bmatrix} -2 & 0 & 1 \\ 0 & 2 & 1 \\ 1 & 1 & 0 \end{bmatrix}$$

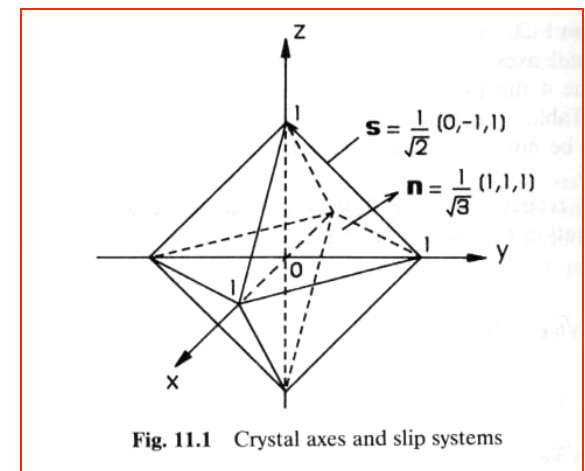

Fig. 11.1 Crystal axes and slip systems

Multiple Slip

From the set of equations, one can obtain 6 relations between the components of D and the 12 shear rates on the 12 slip systems. By taking account of the incompressibility condition, this reduces to only 5 independent relations that can be obtained from the equations.

So, the main task is to determine which combination of 5 independent shear rates, out of 12 possible rates, should be chosen as the solution of a prescribed deformation rate D .

This set of shear rates must satisfy Taylor's minimum shear principle.

Note : There are 792 sets or ${}^{12}C_5$ combinations, of 5 shears, but only 384 are independent. Taylor's minimum shear principle does not ensure that there is a unique solution (a unique set of 5 shears).

Multiple Slip: Strain

- Suppose that we have 5 slip systems that are providing the external slip, D .
- Let's make a vector, D_i , of the (external) strain tensor components and write down a set of equations for the components in terms of the microscopic shear rates, $d\gamma_\alpha$.

- Set $D_2 = d\varepsilon_{22}$, $D_3 = d\varepsilon_{33}$, $D_6 = d\varepsilon_{12}$,
 $D_5 = d\varepsilon_{13}$, and $D_4 = d\varepsilon_{23}$. $m_{ij}^{(\alpha)} = b_i^{(\alpha)} n_j^{(\alpha)}$

$$D_2 = [m_{22}^{(1)} m_{22}^{(2)} m_{22}^{(3)} m_{22}^{(4)} m_{22}^{(5)}] \cdot [d\gamma_1 d\gamma_2 d\gamma_3 d\gamma_4 d\gamma_5]$$

Multiple Slip: Strain

- This notation can obviously be simplified and all five components included by writing it in tabular or matrix form (where the slip system indices are preserved as superscripts in the 5x5 matrix). This is similar to the "basis", \mathbf{b}_p , described by Van Houtte (1988).

$$\begin{bmatrix} D_2 \\ D_3 \\ D_4 \\ D_5 \\ D_6 \end{bmatrix} = \begin{bmatrix} m_{22}^{(1)} & m_{22}^{(2)} & m_{22}^{(3)} & m_{22}^{(4)} & m_{22}^{(5)} \\ m_{33}^{(1)} & m_{33}^{(2)} & m_{33}^{(3)} & m_{33}^{(4)} & m_{33}^{(5)} \\ (m_{23}^{(1)} + m_{32}^{(1)}) & (m_{23}^{(2)} + m_{32}^{(2)}) & (m_{23}^{(3)} + m_{32}^{(3)}) & (m_{23}^{(4)} + m_{32}^{(4)}) & (m_{23}^{(5)} + m_{32}^{(5)}) \\ (m_{13}^{(1)} + m_{31}^{(1)}) & (m_{13}^{(2)} + m_{31}^{(2)}) & (m_{13}^{(3)} + m_{31}^{(3)}) & (m_{13}^{(4)} + m_{31}^{(4)}) & (m_{13}^{(5)} + m_{31}^{(5)}) \\ (m_{12}^{(1)} + m_{21}^{(1)}) & (m_{12}^{(2)} + m_{21}^{(2)}) & (m_{12}^{(3)} + m_{21}^{(3)}) & (m_{12}^{(4)} + m_{21}^{(4)}) & (m_{12}^{(5)} + m_{21}^{(5)}) \end{bmatrix} \begin{bmatrix} d\gamma_1 \\ d\gamma_2 \\ d\gamma_3 \\ d\gamma_4 \\ d\gamma_5 \end{bmatrix}$$

$$\text{or, } \mathbf{D} = \mathbf{E}^T d\boldsymbol{\gamma}$$

```
\begin{bmatrix} D_2 \\ D_3 \\ D_4 \\ D_5 \\ D_6 \end{bmatrix} = \begin{bmatrix} m_{22}^{(1)} & m_{22}^{(2)} & m_{22}^{(3)} & m_{22}^{(4)} & m_{22}^{(5)} \\ m_{33}^{(1)} & m_{33}^{(2)} & m_{33}^{(3)} & m_{33}^{(4)} & m_{33}^{(5)} \\ (m_{23}^{(1)} + m_{32}^{(1)}) & (m_{23}^{(2)} + m_{32}^{(2)}) & (m_{23}^{(3)} + m_{32}^{(3)}) & (m_{23}^{(4)} + m_{32}^{(4)}) & (m_{23}^{(5)} + m_{32}^{(5)}) \\ (m_{13}^{(1)} + m_{31}^{(1)}) & (m_{13}^{(2)} + m_{31}^{(2)}) & (m_{13}^{(3)} + m_{31}^{(3)}) & (m_{13}^{(4)} + m_{31}^{(4)}) & (m_{13}^{(5)} + m_{31}^{(5)}) \\ (m_{12}^{(1)} + m_{21}^{(1)}) & (m_{12}^{(2)} + m_{21}^{(2)}) & (m_{12}^{(3)} + m_{21}^{(3)}) & (m_{12}^{(4)} + m_{21}^{(4)}) & (m_{12}^{(5)} + m_{21}^{(5)}) \end{bmatrix} \begin{bmatrix} d\gamma_1 \\ d\gamma_2 \\ d\gamma_3 \\ d\gamma_4 \\ d\gamma_5 \end{bmatrix}
```

Multiple Slip: Stress

- We can perform the equivalent analysis for stress: just as we can form an external strain component as the sum over the contributions from the individual slip rates, so too we can form the resolved shear stress as the sum over all the contributions from the external stress components (note the inversion of the relationship):

$$\tau = m_{11}\sigma_{11} + m_{22}\sigma_{22} + m_{33}\sigma_{33} + m_{12}\sigma_{12} + m_{21}\sigma_{21} + m_{13}\sigma_{13} + m_{31}\sigma_{31} + m_{23}\sigma_{23} + m_{32}\sigma_{32}$$

Or,

$$\tau = m_{11}\sigma_{11} + m_{22}\sigma_{22} + m_{33}\sigma_{33} + (m_{12} + m_{21})\sigma_{12} + (m_{13} + m_{31})\sigma_{13} + (m_{23} + m_{32})\sigma_{23}$$

Multiple Slip: Stress

- Putting into 5x6 matrix form, as for the strain components, yields:

$$\begin{bmatrix} \tau_1 \\ \tau_2 \\ \tau_3 \\ \tau_4 \\ \tau_5 \end{bmatrix} = \begin{bmatrix} m_{11}^{(1)} m_{22}^{(1)} m_{33}^{(1)} (m_{23}^{(1)} + m_{32}^{(1)}) (m_{13}^{(1)} + m_{31}^{(1)}) (m_{12}^{(1)} + m_{21}^{(1)}) \\ m_{11}^{(2)} m_{22}^{(2)} m_{33}^{(2)} (m_{23}^{(2)} + m_{32}^{(2)}) (m_{13}^{(2)} + m_{31}^{(2)}) (m_{12}^{(2)} + m_{21}^{(2)}) \\ m_{11}^{(3)} m_{22}^{(3)} m_{33}^{(3)} (m_{23}^{(3)} + m_{32}^{(3)}) (m_{13}^{(3)} + m_{31}^{(3)}) (m_{12}^{(3)} + m_{21}^{(3)}) \\ m_{11}^{(4)} m_{22}^{(4)} m_{33}^{(4)} (m_{23}^{(4)} + m_{32}^{(4)}) (m_{13}^{(4)} + m_{31}^{(4)}) (m_{12}^{(4)} + m_{21}^{(4)}) \\ m_{11}^{(5)} m_{22}^{(5)} m_{33}^{(5)} (m_{23}^{(5)} + m_{32}^{(5)}) (m_{13}^{(5)} + m_{31}^{(5)}) (m_{12}^{(5)} + m_{21}^{(5)}) \end{bmatrix} \begin{bmatrix} \sigma_{11} \\ \sigma_{22} \\ \sigma_{33} \\ \sigma_{23} \\ \sigma_{13} \\ \sigma_{12} \end{bmatrix}$$

$$\text{or, } \boldsymbol{\tau} = \mathbf{E} \boldsymbol{\sigma}$$

Definitions of Stress states, slip systems

- Now define a set of *six deviatoric stress* terms, since we know that the hydrostatic component is irrelevant, of which we will actually use only 5:

$$A := (\sigma_{22} - \sigma_{33})$$

$$F := \sigma_{23}$$

$$B := (\sigma_{33} - \sigma_{11})$$

$$G := \sigma_{13}$$

$$C := (\sigma_{11} - \sigma_{22})$$

$$H := \sigma_{12}$$

Note: these systems have the negatives of the slip directions compared to those shown in the lecture on Single Slip (taken from Khan's book), except for b_2 .

- Slip systems (as before):

TABLE 6.1

Slip Plane	111			$\bar{1}\bar{1}\bar{1}$			$\bar{1}\bar{1}1$			1 $\bar{1}\bar{1}$		
Slip Direction	01 $\bar{1}$	$\bar{1}01$	1 $\bar{1}0$	0 $\bar{1}\bar{1}$	101	$\bar{1}10$	01 $\bar{1}$	101	$\bar{1}\bar{1}0$	0 $\bar{1}\bar{1}$	$\bar{1}01$	110
Slip System	a_1	a_2	a_3	b_1	b_2	b_3	c_1	c_2	c_3	d_1	d_2	d_3

[Reid]

Kocks: UQ -UK UP -PK -PQ PU -QU -QP -QK -KP -KU KQ

Multiple Slip: Stress

- Equivalent 5x5 matrix form for the stresses:

$$\begin{bmatrix} \tau_1 \\ \tau_2 \\ \tau_3 \\ \tau_4 \\ \tau_5 \end{bmatrix} = \begin{bmatrix} m_{22}^{(1)} m_{33}^{(1)} (m_{23}^{(1)} + m_{32}^{(1)}) (m_{13}^{(1)} + m_{31}^{(1)}) (m_{12}^{(1)} + m_{21}^{(1)}) \\ m_{22}^{(2)} m_{33}^{(2)} (m_{23}^{(2)} + m_{32}^{(2)}) (m_{13}^{(2)} + m_{31}^{(2)}) (m_{12}^{(2)} + m_{21}^{(2)}) \\ m_{22}^{(3)} m_{33}^{(3)} (m_{23}^{(3)} + m_{32}^{(3)}) (m_{13}^{(3)} + m_{31}^{(3)}) (m_{12}^{(3)} + m_{21}^{(3)}) \\ m_{22}^{(4)} m_{33}^{(4)} (m_{23}^{(4)} + m_{32}^{(4)}) (m_{13}^{(4)} + m_{31}^{(4)}) (m_{12}^{(4)} + m_{21}^{(4)}) \\ m_{22}^{(5)} m_{33}^{(5)} (m_{23}^{(5)} + m_{32}^{(5)}) (m_{13}^{(5)} + m_{31}^{(5)}) (m_{12}^{(5)} + m_{21}^{(5)}) \end{bmatrix} \begin{bmatrix} -C \\ B \\ F \\ G \\ H \end{bmatrix}$$

- Note that it is feasible to invert the matrix, provided that its determinant is non-zero, which it will only be true if the 5 slip systems chosen are linearly independent.

$$\sigma = \mathbf{E}^{-1} \tau$$

Multiple Slip: Stress/Strain Comparison

- The last matrix equation is in the same form as for the strain components.
- We can test for the availability of a solution by calculating the determinant of the “E” matrix, as in:

$$\tau = \mathbf{E} \sigma$$

$$\text{or, } \mathbf{D} = \mathbf{E}^T d\gamma$$

- A non-zero determinant of \mathbf{E} means that a solution is available.
- Even more important, the direct form of the stress equation means that, if we assume a fixed critical resolved shear stress, then we can compute all the possible multislip stress states, based on the set of linearly independent combinations of slip:

$$\sigma = \mathbf{E}^{-1} \tau$$

- It must be the case that, of the 96 sets of 5 independent slip systems, the stress states computed from them collapse down to only the 28 (+ and -) found by Bishop & Hill.
- The Taylor approach can be used to find a solution for a set of active slip systems that satisfies the minimum (microscopic) work criterion. The most effective approach is to use the simplex method because the multiple possible solutions mean that the problem is mathematically *underdetermined*. A complete description is found in the 1988 review paper by Van Houtte [*Textures and Microstructures* **8 & 9** 313-350].
- The simplex method is also useful for analyzing geometrically necessary dislocation (GND) content, see El-Dasher *et al.* [*Scripta mater.* **48** 141 (2003)].

Bishop and Hill model

- This section describes the alternate approach of Bishop and Hill. This enumerates the corners (vertices) of the single crystal yield surface that permit multiple slip with 6 or 8 systems.

Maximum Work Principle

- Bishop and Hill introduced a *maximum work principle*, which in turn was based on Hill's work on plasticity*. The papers are available as 1951-PhilMag-Bishop_Hill-paper1.pdf and 1951-PhilMag-Bishop_Hill-paper2.pdf.
- This states that, among the available (multiaxial) stress states that activate a minimum of 5 slip systems, the operative stress state is that which maximizes the work done.
- In equation form, $\delta w = \sigma_{ij} d\varepsilon_{ij} \geq \sigma^*_{ij} d\varepsilon_{ij}$, where the operative stress state is unprimed.
- For cubic materials, it turns out that the list of discrete multiaxial stress states is quite short (28 entries). Therefore the Bishop-Hill approach is much more convenient from a numerical perspective.
- The algebra is non-trivial, but the maximum work principle is equivalent to Taylor's minimum shear (microscopic work) principle.
- In geometrical terms, the maximum work principle is equivalent to seeking the stress state that is most nearly parallel (in direction) to the strain rate direction.

*Hill, R. (1950). *The Mathematical Theory of Plasticity*, Clarendon Press, Oxford.

Yield surfaces: introduction

- Before discussing the B-H approach, it is helpful to understand the concept of a *yield surface*.
- The best way to learn about yield surfaces is think of them as a graphical construction.
- A **yield surface** is the boundary between elastic and plastic flow.

Example: tensile stress

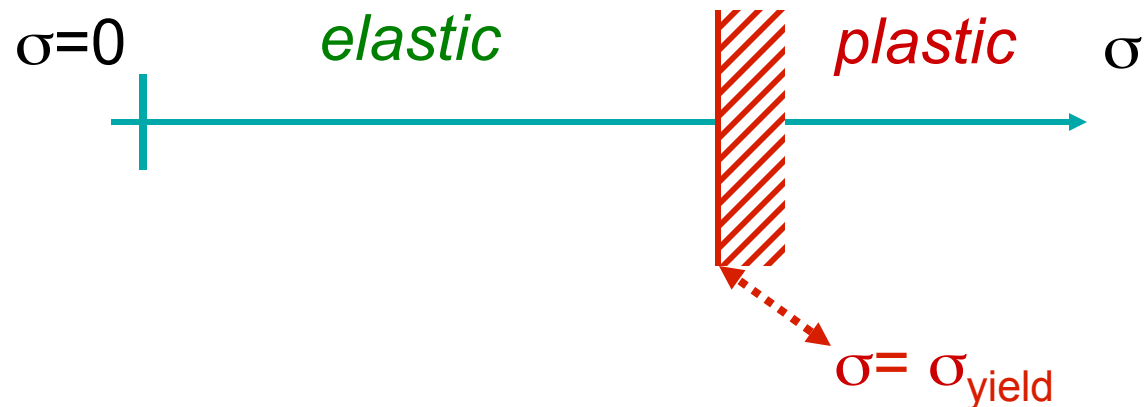

2D yield surfaces

- Yield surfaces can be defined in two dimensions.
- Consider a combination of (independent) yield on two different axes.

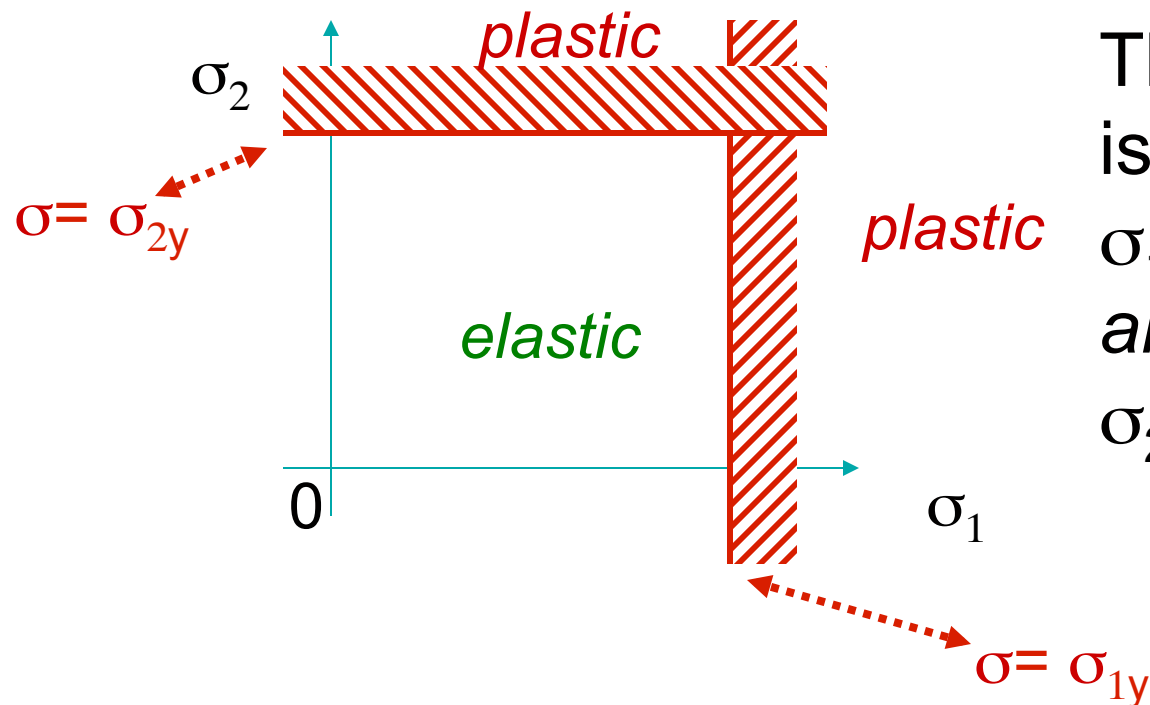

The material
is elastic if

$$\sigma_1 < \sigma_{1y}$$

and

$$\sigma_2 < \sigma_{2y}$$

Crystallographic slip: a single system

- Now that we understand the concept of a yield surface we can apply it to crystallographic slip.
- The result of slip on a single system is strain in a single direction, which appears as a straight line on the Y.S.
- The strain direction that results from this system is necessarily perpendicular to the yield surface

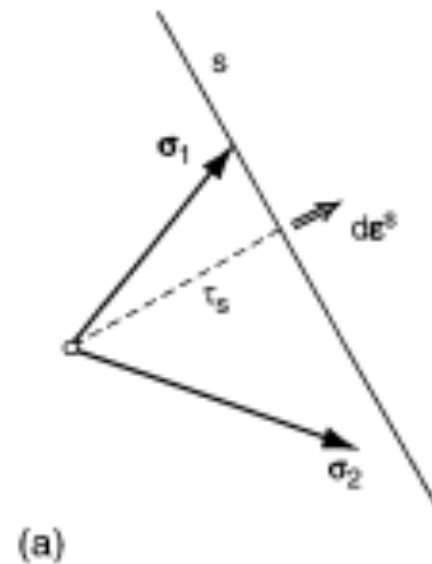

[Kocks]

A single slip system

- Yield criterion for single slip:

$$b_i \sigma_{ij} n_j \geq \tau_{crss}$$

- In 2D this becomes ($\sigma_1 \equiv \sigma_{11}$):

$$b_1 \sigma_1 n_1 + b_2 \sigma_2 n_2 \geq \tau_{crss}$$

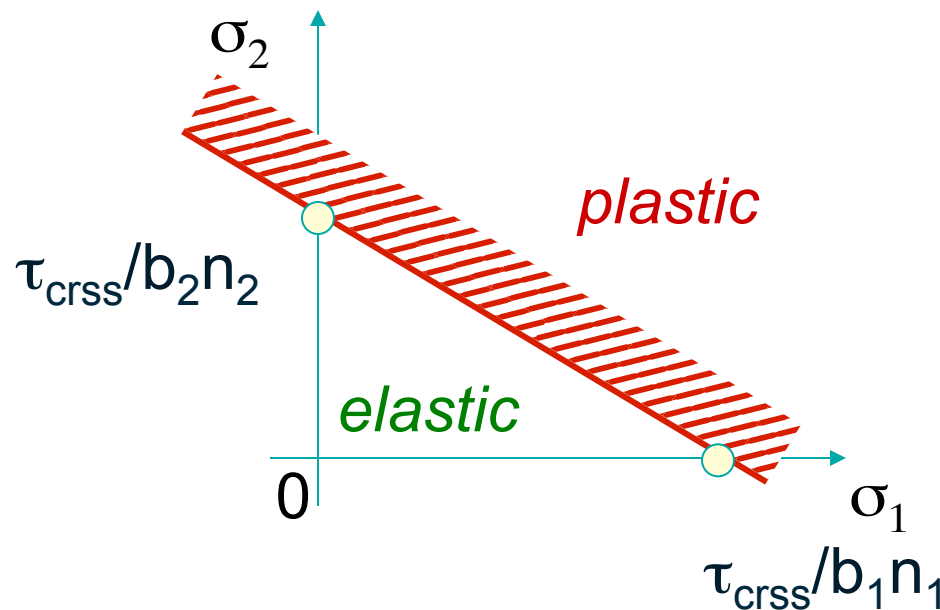

The second equation defines a straight line connecting the intercepts

Single crystal Y.S.

- When we examine yield surfaces for specific orientations, we find that multiple slip systems meet at *vertices*.
- Cube component: (001)[100]

The 8-fold vertex identified is one of the 28 Bishop & Hill stress states (next slides)

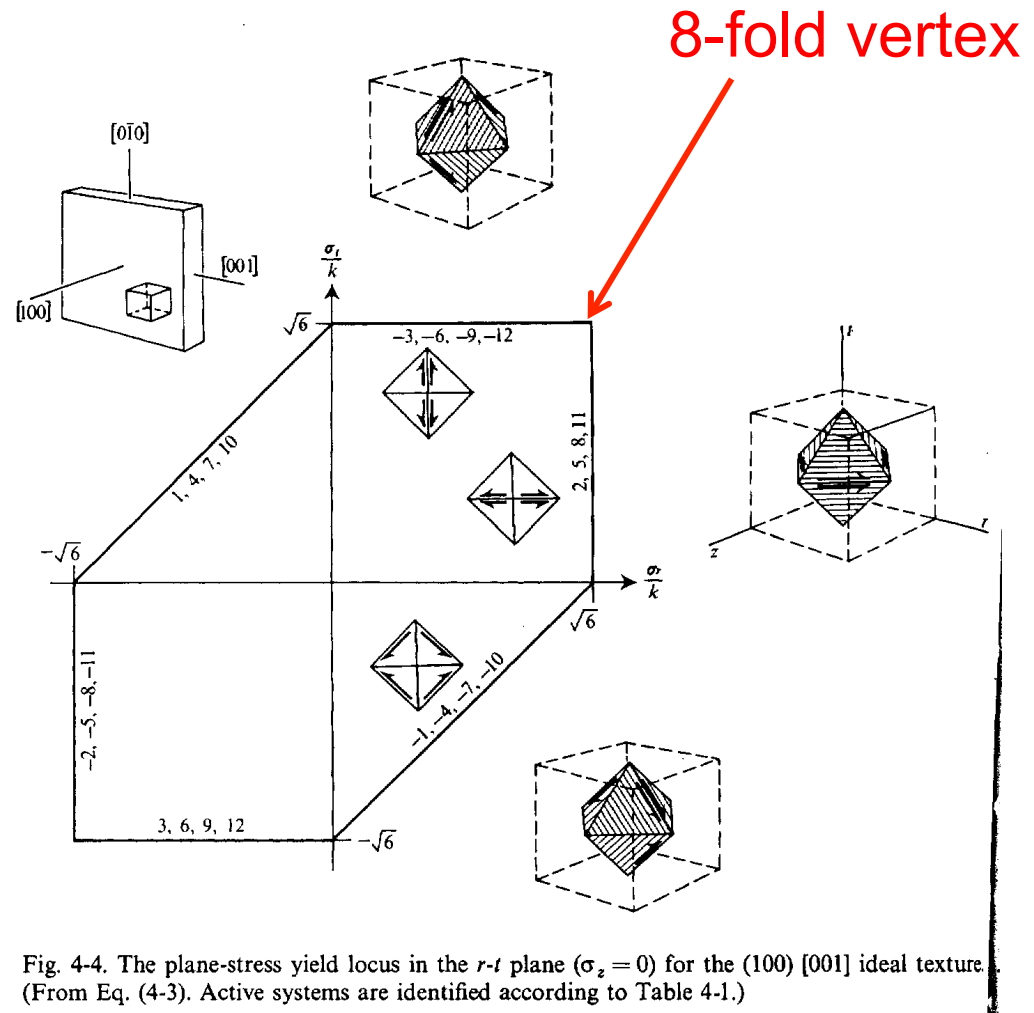

Fig. 4-4. The plane-stress yield locus in the $r-t$ plane ($\sigma_z = 0$) for the (100) [001] ideal texture. (From Eq. (4-3). Active systems are identified according to Table 4-1.)

Definitions of Stress states, slip systems (repeat)

- A set of *six deviatoric stress* terms can be defined. As previously remarked we know that the hydrostatic component is irrelevant because dislocation glide does not result in any volume change. Therefore we will use only 5 out of the 6:

$$A := (\sigma_{22} - \sigma_{33})$$

$$F := \sigma_{23}$$

$$B := (\sigma_{33} - \sigma_{11})$$

$$G := \sigma_{13}$$

$$C := (\sigma_{11} - \sigma_{22})$$

$$H := \sigma_{12}$$

Note: these systems have the negatives of the slip directions compared to those shown in the lecture on Single Slip (taken from Khan's book), except for b_2 .

- *Slip systems* (as before):

TABLE 6.1

Slip Plane	111			$\bar{1}\bar{1}1$			$\bar{1}1\bar{1}$			$1\bar{1}\bar{1}$		
Slip Direction	01 $\bar{1}$	$\bar{1}01$	1 $\bar{1}0$	0 $\bar{1}\bar{1}$	101	$\bar{1}10$	01 $\bar{1}$	101	$\bar{1}\bar{1}0$	0 $\bar{1}\bar{1}$	$\bar{1}01$	110
Slip System	a_1	a_2	a_3	b_1	b_2	b_3	c_1	c_2	c_3	d_1	d_2	d_3

[Reid]

Kocks: UQ -UK UP -PK -PQ PU -QU -QP -QK -KP -KU KQ

Multi-slip stress states

Each entry is in multiples of $\sqrt{6}$ multiplied by the critical resolved shear stress, $\sqrt{6}\tau_{crss}$

Example:
the 18th multi-slip stress state:

$$A=F= 0$$

$$B=G= -0.5$$

$$C=H= 0.5$$



TABLE 6.2. STRESS STATES FOR {111} (110) OR {110} (111) SLIP

Number of stress state	A	B	C	F	G	H	a ₁	a ₂	a ₃	b ₁	b ₂	b ₃	c ₁	c ₂	c ₃	d ₁	d ₂	d ₃	Number of active slip systems
1	1	-1	0	0	0	0	+	-		+	-		+	-		+	-		8
2	0	1	-1	0	0	0		+	-		+	-		+	-		+	-	8
3	-1	0	1	0	0	0	-		+	-		+	-		+	-		+	8
4	0	0	0	1	0	0		+	-		-	+		+	-		-	+	8
5	0	0	0	0	1	0	-		+	+		-	+		-	-		+	8
6	0	0	0	0	0	1	+	-		+	-		-	+		-	+		8
7	½	-1	½	0	½	0		-	+	+	-		+	-		-	-	+	8
8	½	-1	½	0	-½	0	+	-			-	+		-	+	+	-		8
9	-1	½	½	½	0	0	-	+		-		+		-	+	-		+	8
10	-1	½	½	-½	0	0	-		+	-	+			-	+	-		+	8
11	½	½	-1	0	0	½	+		-	+		-		+	-		+	-	8
12	½	½	-1	0	0	-½	+		-		+		+		-	+		-	8

13	½	0	-½	½	0	½	+		-	+	-		+	-		-	-		6
14	½	0	-½	-½	0	½	+	-		+	-			-		+	-		6
15	½	0	-½	½	0	-½		+	-			+		-		+	-		6
16	½	0	-½	-½	0	-½			+		+	-		+	-		+	-	6
17	0	-½	½	0	½	½		-	+	+	-			-		-	+		6
18	0	-½	½	0	-½	½	+	-			-	+		-	+		+		6
19	0	-½	½	0	½	-½	-		+				+	-		-	+		6
20	0	-½	½	0	-½	-½			+		-		+	-		+	+	-	6
21	-½	½	0	½	½	0	-	+			+	-		+	-		-	+	6
22	-½	½	0	-½	½	0	-		+		+	-		-		-	+		6
23	-½	½	0	½	-½	0		+	-	-		+		-	+		-		6
24	-½	½	0	-½	-½	0			+		-	+		-		+	+	-	6
25	0	0	0	½	½	-½	-	+					+	-		-	+		6
26	0	0	0	½	-½	½	+		-		-	+		-	+		-		6
27	0	0	0	-½	½	½		-	+	+		-			-	-	+		6
28	0	0	0	½	½	½				+	-				+	-	-	+	6

Work Increment

- The work increment is easily expanded as:

$$\delta w = \sigma_{11}d\varepsilon_{11} + \sigma_{22}d\varepsilon_{22} + \sigma_{33}d\varepsilon_{33} + \sigma_{12}d\varepsilon_{12} + \sigma_{21}d\varepsilon_{21} + \sigma_{13}d\varepsilon_{13} + \sigma_{31}d\varepsilon_{31} + \sigma_{23}d\varepsilon_{23} + \sigma_{32}d\varepsilon_{32}$$

Simplifying by noting the symmetric property of stress and strain:

$$\delta w = \sigma_{11}d\varepsilon_{11} + \sigma_{22}d\varepsilon_{22} + \sigma_{33}d\varepsilon_{33} + 2\sigma_{12}d\varepsilon_{12} + 2\sigma_{13}d\varepsilon_{13} + 2\sigma_{23}d\varepsilon_{23}$$

Then we apply the fact that the hydrostatic component of the strain is zero (incompressibility), and apply our notation for the deviatoric components of the stress tensor (next slide).

Applying Maximum Work

- For each of 56 (with positive and negative copies of each stress state), find the one that maximizes dW :

$$dW = -Bd\varepsilon_{11} + Ad\varepsilon_{22} + \\ 2Fd\varepsilon_{23} + 2Gd\varepsilon_{13} + 2Hd\varepsilon_{12}$$

Reminder: the strain (increment) tensor *must be in grain (crystallographic) coordinates* (see next page); also make sure that its von Mises equivalent strain = 1.

Sample vs. Crystal Axes

- For a general orientation, one must pay attention to the product of the axis transformation that puts the strain increment in crystal coordinates. Although one should, in general, symmetrize the new strain tensor expressed in crystal axes, it is sensible to leave the new components as is and form the work increment as follows (using the *tensor transformation rule*):

$$de_{ij}^{crystal} = g_{ik} g_{jl} d\epsilon_{kl}^{sample}$$

Be careful with the indices and the fact that the above formula does *not* correspond to matrix multiplication (but one can use the particular formula for 2nd rank tensors, i.e. $T' = g T g^T$)

$$\begin{aligned} \delta w = & -Bde_{11} + Ade_{22} + F(de_{23} + de_{32}) \\ & + G(de_{13} + de_{31}) + H(de_{12} + de_{21}) \end{aligned}$$

Note that the shear terms (with F, G & H) do *not* have the factor of two. Many worked examples choose symmetric orientations in order to avoid this issue!

Taylor Factor

- This section explains what the Taylor is and how to obtain it, with a worked example.

Taylor factor

- From this analysis emerges the fact that the same ratio couples the magnitudes of the (sum of the) microscopic shear rates and the macroscopic strain, and the macroscopic stress and the critical resolved shear stress. This ratio is known as the *Taylor factor*, in honor of the discoverer. For simple uniaxial tests with only one non-zero component of the external stress/strain, we can write the Taylor factor as a ratio of stresses or of strains. If the strain state is multiaxial, however, a decision must be made about how to measure the magnitude of the strain, and we follow the practice of Canova, Kocks *et al.* by choosing the *von Mises equivalent strain* (defined in the next two slides).
- In the general case, the crss values can vary from one system to another. Therefore it is easier to use the strain increment based definition.

$$M = \frac{\sigma}{\tau_{crss}} = \frac{\sum_{\alpha} d\gamma^{(\alpha)}}{d\varepsilon} = \frac{dW}{\tau_{crss} d\varepsilon_{vM}}$$

Taylor factor, multiaxial stress

- For multiaxial stress states, one may use the effective stress, e.g. the von Mises stress (defined in terms of the stress deviator tensor, $\mathbf{S} = \boldsymbol{\sigma} - (\sigma_{ii}/3)$, and also known as *effective stress*). Note that the equation below provides the most self-consistent approach for calculating the Taylor factor for multi-axial deformation.

$$\sigma_{vonMises} \equiv \sigma_{vM} = \sqrt{\frac{3}{2} \mathbf{S} : \mathbf{S}}$$

$$M = \frac{\sigma_{vM}}{\tau} = \frac{\sum_s \Delta \gamma^{(s)}}{d\varepsilon_{vM}} = \frac{dW}{\tau_c d\varepsilon_{vM}} = \frac{\boldsymbol{\sigma} : d\boldsymbol{\varepsilon}}{\tau_c d\varepsilon_{vM}}$$

Taylor factor, multiaxial strain

- Similarly for the strain increment (where $d\varepsilon_p$ is the plastic strain increment which has zero trace, i.e. $d\varepsilon_{ii}=0$).

$$d\varepsilon_{\text{vonMises}} \equiv d\varepsilon_{vM} = \sqrt{\frac{2}{3} d\varepsilon_p : d\varepsilon_p} = \frac{2}{\sqrt{3}} \sqrt{\frac{1}{2} d\varepsilon_{ij} : d\varepsilon_{ij}} =$$

$$*** \sqrt{\left(\frac{2}{9}\right) \left\{ (d\varepsilon_{11} - d\varepsilon_{22})^2 + (d\varepsilon_{22} - d\varepsilon_{33})^2 + (d\varepsilon_{33} - d\varepsilon_{11})^2 \right\} + \frac{1}{3} \left\{ d\varepsilon_{23}^2 + d\varepsilon_{31}^2 + d\varepsilon_{12}^2 \right\}}$$

$$M = \frac{\sigma_{vM}}{\tau} = \frac{\sum_s \Delta\gamma^{(s)}}{d\varepsilon_{vM}} = \frac{dW}{\tau_c d\varepsilon_{vM}} = \frac{\sigma : d\varepsilon}{\tau_c d\varepsilon_{vM}}$$

Compare with single slip: Schmid factor = $\cos\phi\cos\lambda = \tau/\sigma$

*** This version of the formula applies *only* to the symmetric form of $d\varepsilon$

Polycrystals

- Given a set of grains (orientations) comprising a polycrystal, one can calculate the Taylor factor, M , for each one as a function of its orientation, g , weighted by its volume fraction, v , and make a volume-weighted average, $\langle M \rangle$.

$$\langle M \rangle = \sum_{i=1}^N v_i M(g_i)$$

- Note that exactly the same average can be made for the lower-bound or *Sachs model* by averaging the *inverse Schmid factors* ($1/m$).

Multi-slip: Worked Example

Objective is to find the *multislip stress state* and *slip distribution* for a crystal undergoing plane strain compression. Quantities in the sample frame have primes (') whereas quantities in the crystal frame are unprimed; the "a" coefficients form an *orientation matrix* ("g").

Worked Example 6.2. Q. Suppose that we carry out a compression test on a rectangular single crystal, preventing it from expanding in one transverse direction (a plane-strain compression test). This is conveniently achieved by placing the crystal in a channel, as illustrated in Fig. 6.7. Which slip systems will operate, and what will the compressive yield strength be? Suppose that the direction of compression is $Ox'_2 = [110]$ and the channel lies along $Ox'_1 = [\bar{1}10]$ (permitting expansion along this direction), and that slip occurs on the $\{110\} \langle 111 \rangle$ systems.

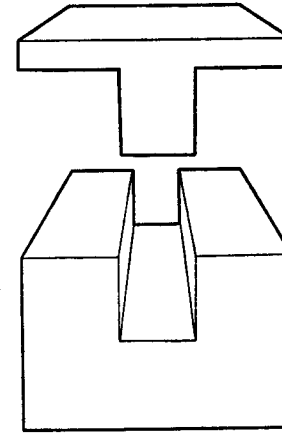

Figure 6.7 A sketch of an anvil and die used for plane-strain compression.

A. The longitudinal strain increments along Ox'_1 , Ox'_2 and Ox'_3 are respectively $\delta\epsilon'_{11}$, $\delta\epsilon'_{22}$ and $\delta\epsilon'_{33}$. Due to the constraint of the channel $\delta\epsilon'_{33}$ is zero, and since the volume remains unchanged

$$\delta\epsilon'_{11} = -\delta\epsilon'_{22}$$

If the crystal retains its rectangular shape during deformation

$$\delta\epsilon'_{12} = \delta\epsilon'_{23} = \delta\epsilon'_{13} = 0$$

The strain increment $\delta\epsilon_{ij}$ relative to the cube axes is obtained from $\delta\epsilon'_{ij}$ by the transformation (see Appendix)

$$\delta\epsilon_{ij} = a_{ki}a_{lj}\delta\epsilon'_{kl}$$

where the a 's are direction cosines from the array

	100	010	001
110	$-1/\sqrt{2}$	$1/\sqrt{2}$	0
110	$1/\sqrt{2}$	$1/\sqrt{2}$	0
001	0	0	1

$$\delta\epsilon_{11} = \frac{1}{2}\delta\epsilon'_{11} + \frac{1}{2}\delta\epsilon'_{22} = 0$$

$$\delta\epsilon_{22} = \frac{1}{2}\delta\epsilon'_{11} + \frac{1}{2}\delta\epsilon'_{22} = 0$$

$$\delta\epsilon_{12} = -\frac{1}{2}\delta\epsilon'_{11} + \frac{1}{2}\delta\epsilon'_{22} = -\delta\epsilon'_{11}$$

$$\delta\epsilon_{13} = 0$$

$$\delta\epsilon_{23} = 0$$

[Reid]

Multi-slip: Worked Example

- This worked example for a bcc multislip case shows you how to apply the *maximum work principle* to a practical problem.
- Important note: Reid chooses to divide the work increment by the value of $\delta\varepsilon_{11}$. This gives a different answer than that obtained with the *von Mises equivalent strain* (e.g. in LApp). Instead of $2\sqrt{6}$ as given here, the answer is $\sqrt{3}\sqrt{6} = \sqrt{18}$.

In this example from Reid, “orientation factor” = Taylor factor = M

In this case, the work done is simply

$$\delta w = -2H \delta\varepsilon'_{11} \quad \text{from eqn. 6.11}$$

and this has maximum value when $H = -1$ (the negative of stress state number six). Eight slip systems may be activated: $-a_1, a_2, -b_1, b_2, c_1, -c_2, d_1$ and $-d_2$. Since Table 6.2 uses units of $\sqrt{(6)}\tau_c$, $H = -\sqrt{(6)}\tau_c$ and

$$\delta w = 2\sqrt{(6)}\tau_c \delta\varepsilon'_{11}$$

If the compression stress P causes $\delta\varepsilon'_{11}$, then the work done by the external agency is $P \delta\varepsilon'_{11}$, and this must equal the work done on all the operating slip systems, $\tau_c \sum \delta\gamma$, per unit volume of crystal.

So
$$\delta w = P \delta\varepsilon'_{11} = \tau_c \sum \delta\gamma$$

We often use an orientation factor, M , which is defined by eqn. 6.8

$$M = P/\tau_c = \sum \delta\gamma/\delta\varepsilon'_{11} = \delta w/(\tau_c \delta\varepsilon'_{11})$$

The yield strength of the crystal will be $(M\tau_c)$, where τ_c is the shear strength. In this example $M = 2\sqrt{6}$; this is the largest possible value of M using the $\{110\} \langle 111 \rangle$ slip systems, so we can say that the orientation of crystal in this example is the hardest, i.e. it requires the largest compression stress, P , for a given increment of strain, $\delta\varepsilon'_{11}$.

The M values and active systems can be calculated in the same way for other orientations of plane strain compression, and the results for various orientations are summarised in Table 6.3. Note that in certain orientations, two stress states maximise the work done. In such cases, the operative slip systems will be those that are *common to both stress states*, and there is no ambiguity about the choice of active systems.

Bishop-Hill Method: pseudo-code

- How to calculate the Taylor factor using the Bishop-Hill model?
 1. Identify the orientation of the crystal, g ;
 2. Transform the strain into crystal coordinates;
 3. Calculate the work increment (product of one of the discrete multislip stress states with the transformed strain tensor) for each one of the 28 discrete stress states that allow multiple slip;
 4. The operative stress state is the one that is associated with the largest magnitude (absolute value) of work increment, dW ;
 5. The Taylor factor is then equal to the maximum work increment divided by the von Mises equivalent strain.

Note: given that the magnitude (in the sense of the von Mises equivalent) is constant for both the strain increment and each of the multi-axial stress states, why does the Taylor factor vary with orientation?! The answer is that it is the *dot product* of the stress and strain that matters, and that, as you vary the orientation, so the geometric relationship between the strain direction and the set of multislip stress states varies.

$$M = \frac{\sigma : d\epsilon}{\tau_c d\epsilon_{vM}}$$

Multiple Slip - Slip System Selection

- So, now you have figured out what the stress state is in a grain that will allow it to deform. What about the slip rates on each slip system?!
- The problem is that neither Taylor nor Bishop & Hill say anything about which of the many possible solutions is the correct one!
- For any given orientation and required strain, there is a range of possible solutions: in effect, different combinations of 5 out of 6 or 8 slip systems that are loaded to the critical resolved shear stress can be active and used to solve the equations that relate microscopic slip to macroscopic strain.
- Modern approaches use the physically realistic strain rate sensitivity on each system to “round the corners” of the single crystal yield surface. This will be discussed in later slides in the section on Grain Reorientation.
- Even in the rate-insensitive limit discussed here, it is possible to make a random choice out of the available solutions.
- The review of Taylor’s work that follows shows the “ambiguity problem” as this is known, through the variation in possible re-orientation of an fcc crystal undergoing tensile deformation (shown on a later slide).

Taylor's Rigid Plastic Model for Polycrystals: Hardening and Reorientation of the Lattice

- This was the first model to describe, successfully, the stress-strain relation as well as the texture development of polycrystalline metals in terms of the single crystal constitutive behavior, for the case of uniaxial tension.
- Taylor used this model to solve the problem of a polycrystalline FCC material, under uniaxial, axisymmetric tension and show that the *polycrystal hardening* behavior could be understood in terms of the hardening of a *single type of slip system*. In other words, the hardening rule (a.k.a. constitutive description) applies at the level of the individual slip system.

Taylor model basis

- If large plastic strains are accumulated in a body then it is unlikely that any single grain (volume element) will have deformed much differently from the average (as previously discussed). The reason for this is that any accumulated differences lead to either a gap or an overlap between adjacent grains. Overlaps are exceedingly unlikely because most plastic solids are essentially incompressible. Gaps are simply not observed in ductile materials, though they are admittedly common in marginally ductile materials. This then is the "compatibility-first" justification, i.e. that the elastic energy cost for large deviations in strain between a given grain and its matrix are very large.

Uniform strain assumption

$$dE^{\text{local}} = dE^{\text{global}},$$

where the global strain is simply the average strain and the local strain is simply that of the grain or other subvolume under consideration. This model means that stress equilibrium cannot be satisfied at grain boundaries because the stress state in each grain is generally not the same as in its neighbors. It is assumed that reaction stresses are set up near the boundaries of each grain to account for the variation in stress state from grain to grain.

Taylor Model for Polycrystals

In this model, it is assumed

- ❖ The elastic deformation is small when compared to the plastic strain.
- ❖ Each grain of the single crystal is subjected to the same homogeneous deformation imposed on the aggregate,

deformation

$$\left\{ \begin{array}{l} \text{Infinitesimal - } \boldsymbol{\varepsilon}_{grain} = \langle \boldsymbol{\varepsilon} \rangle, \quad \dot{\boldsymbol{\varepsilon}}_{grain} = \langle \dot{\boldsymbol{\varepsilon}} \rangle \\ \text{Large - } \boldsymbol{L}_{grain} = \langle \boldsymbol{L} \rangle, \quad \boldsymbol{D}_{grain} = \langle \boldsymbol{D} \rangle \end{array} \right.$$

Taylor Model: Hardening Alternatives

- The simplest assumption of all (rarely used in polycrystal plasticity) is that all slip systems in all grains harden at the same rate, h .

$$d\tau = h \langle d\gamma \rangle_{polyxtal}$$

- The most common assumption (often used in polycrystal plasticity) is that all slip systems in each grain harden at the same rate. In this case, each grain hardens at a different rate: the higher the Taylor factor, the higher the hardening rate (because the larger amount of microscopic slip). The sum i is over all the active slip systems.

$$d\tau = h \sum_i d\gamma^{(i)}$$

Taylor Model: Hardening Alternatives, contd.

- The next level of complexity is to allow each slip system to harden as a function of the slip on all the slip systems, where the hardening coefficient may be different for each system. This allows for different hardening rates as a function of how each slip system interacts with each other system (e.g. co-planar, non-co-planar etc.). Note that, to obtain the *crss* for the j^{th} system (in the i^{th} grain) one must sum up over all the slip system activities.

$$d\tau_j^{(i)} = \sum_k h_{jk} d\gamma_k^{(i)}$$

Taylor Model: Work Increment

- Regardless of the hardening model, the work done in each strain increment is the same, whether evaluated externally, or from the shear strains. The average over the stresses in each grain is equivalent to making an average of the Taylor factors (and multiplying by the CRSS).

$$dW = \langle \sigma \rangle_{polycrystal} d\varepsilon = \left\langle \sum_k \tau_k(\gamma) d\gamma_k \right\rangle_{polycrystal}$$

Taylor Model: Comparison to Polycrystal

The stress-strain curve obtained for the aggregate by Taylor in his work is shown in the figure. Although a comparison of single crystal (under multislip conditions) and a polycrystal is shown, it is generally considered that the good agreement indicated by the lines was somewhat fortuitous!

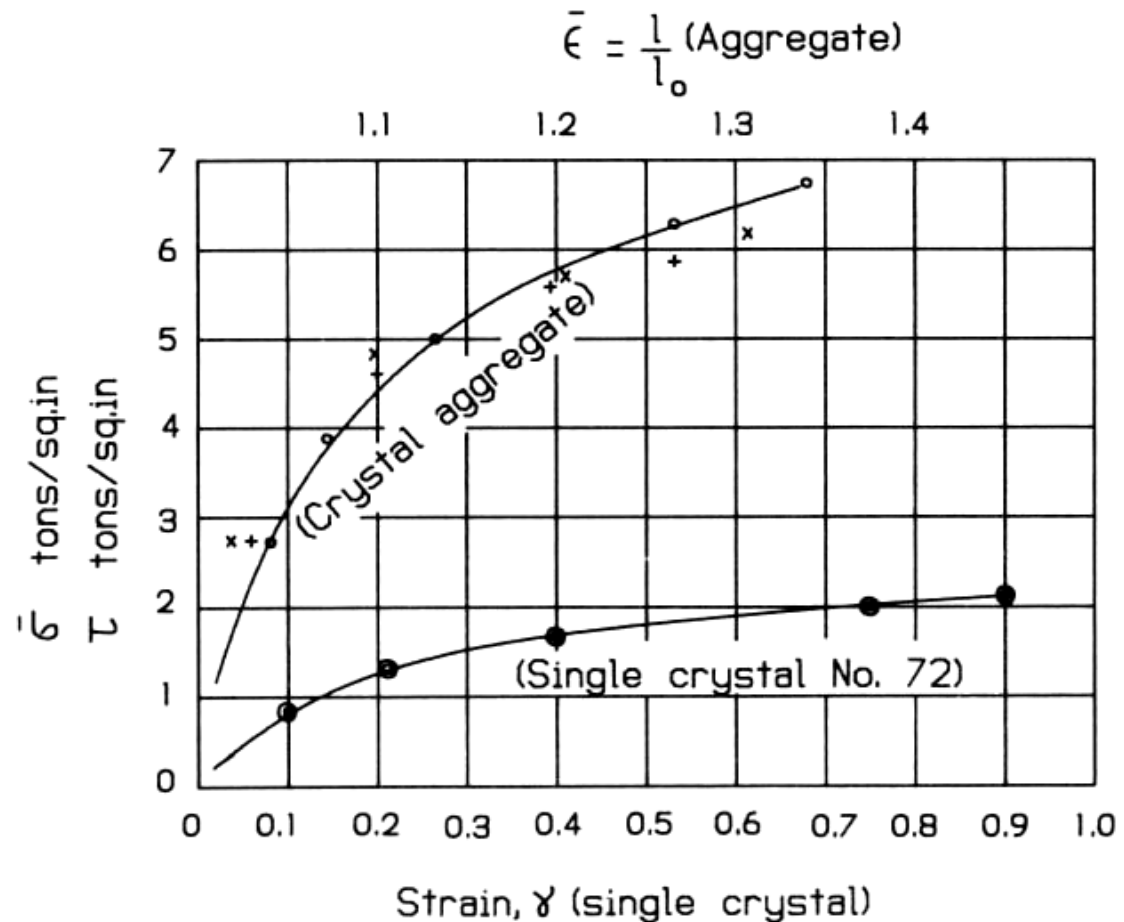

Fig. 11.3 Prediction of polycrystal stress-strain curve from a single-crystal stress-strain curve (after Taylor 1937)

Note:

Circles - computed data

Crosses – experimental data

The ratio between the two curves is the average Taylor factor, which in this case is ~ 3.1

Taylor's Rigid Plastic Model for Polycrystals

Another important conclusion based on this calculation, is that the overall stress-strain curve of the polycrystal is given by the expression

$$\sigma = \langle M \rangle \tau(\gamma)$$

Where,

$\tau(\gamma)$ is the critical resolved shear stress (CRSS as a function of the shear strain) for a single crystal, assumed to have a single value;

$\langle M \rangle$ is an average value of the Taylor factor of all the grains (which changes with strain).

By Taylor's calculation, for FCC polycrystal metals,

$$\langle M \rangle = 3.1$$

Updating the Lattice Orientation

- This section analyzes one approach to computing the change in lattice orientation that results from slip. The number of slip systems is not restricted to any particular value.

Taylor Model: Grain Reorientation

For texture development it is necessary to obtain the total spin for the aggregate. Note that since all the grains are assumed to be subjected to the same displacement (or velocity field) as the aggregate, the total rotation experienced by each grain will be the same as that of the aggregate. The q introduced here can be thought of as the skew-symmetric counterpart to the Schmid tensor.

For uniaxial tension

$$W = W^* = 0$$

Note: "W" denotes spin here, not work done

Then,

$$dW^e = -dW^c = \sum_{\alpha=1} q^{(\alpha)} d\gamma^{(\alpha)}$$

Note: $W^e = W - W^c$

$$q_{ij}^{(\alpha)} = \frac{1}{2} \left(\hat{b}_i^{(\alpha)} \hat{n}_j^{(\alpha)} - \hat{b}_j^{(\alpha)} \hat{n}_i^{(\alpha)} \right)$$

Taylor model: Reorientation: 1

- Review of effect of slip system activity:
- Symmetric part of the distortion tensor resulting from slip:

$$m_{ij}^{(s)} = \frac{1}{2} \left(\hat{b}_i^{(s)} \hat{n}_j^{(s)} + \hat{b}_j^{(s)} \hat{n}_i^{(s)} \right)$$

- Anti-symmetric part of Deformation Strain Rate Tensor (used for calculating lattice rotations, sum over active slip systems):

$$q_{ij}^{(s)} = \frac{1}{2} \left(\hat{b}_i^{(s)} \hat{n}_j^{(s)} - \hat{b}_j^{(s)} \hat{n}_i^{(s)} \right)$$

Taylor model: Reorientation: 2

- Strain rate from slip (add up contributions from all active slip systems):

$$D^C = \sum_s \dot{\gamma}^{(s)} m^{(s)}$$

- Rotation rate from slip, W^C , (add up contributions from all active slip systems):

$$W^C = \sum_s \dot{\gamma}^{(s)} q^{(s)}$$

Taylor model: Reorientation: 3

- Rotation rate of crystal axes (W^*), where we account for the rotation rate of the grain itself, W^g :

$$W^* = W^g - W^C$$

Crystal axes
grain
slip

- Rate sensitive formulation for slip rate in each crystal (solve as implicit equation for stress):

$$D^C = \dot{\epsilon}_0 \sum_s \left| \frac{m^{(s)} : \sigma^c}{\tau^{(s)}} \right|^{n^{(s)}} m^{(s)} \operatorname{sgn}(m^{(s)} : \sigma^c)$$

$= \tau^{(s)}$

Taylor model: Reorientation: 4

- The shear strain rate on each system is also given by the power-law relation (once the stress is determined):

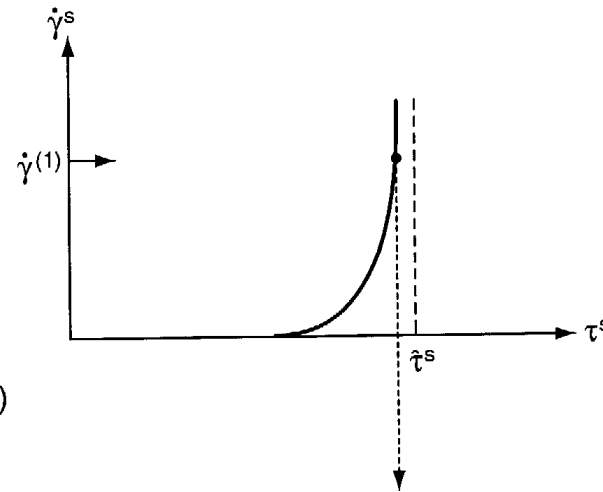

$$\dot{\gamma}^{(s)} = \dot{\epsilon}_0 \left| \frac{m^{(s)} : \sigma^c}{\tau^{(s)}} \right|^{n^{(s)}} \text{sgn}(m^{(s)} : \sigma^c)$$

= $\tau^{(s)}$
= $\tau^{(s)}$

Iteration to determine stress state in each grain

- An iterative procedure is required to find the solution for the stress state, σ^c , in each grain (at each step). Note that the strain rate (as a tensor) is imposed on each grain, i.e. *boundary conditions based on strain*. Once a solution is found, then individual slipping rates (shear rates) can be calculated for each of the s slip systems. The use of a rate sensitive formulation for yield avoids the necessity of *ad hoc* assumptions to resolve the ambiguity of slip system selection.
- Within the LApp code, the relevant subroutines are SSS and NEWTON

Update orientation: 1

- General formula for rotation matrix:

$$a_{ij} = \delta_{ij} \cos \theta + e_{ijk} n_k \sin \theta + (1 - \cos \theta) n_i n_j$$

- In the small angle limit ($\cos \theta \sim 1$, $\sin \theta \sim \theta$):

$$a_{ij} = \delta_{ij} + e_{ijk} n_k \theta$$

Update orientation: 2

- In tensor form (*small* rotation approx.):

$$\mathbf{R} = \mathbf{I} + \mathbf{W}^*$$

- General relations:

$$\boldsymbol{\omega} = 1/2 \operatorname{curl} \mathbf{u} = 1/2 \operatorname{curl}\{\mathbf{x}-\mathbf{X}\}$$

- $\mathbf{u} :=$ displacement

$$\omega_i = \frac{1}{2} e_{ijk} \partial u_k / \partial X_j$$

$$\Omega_{jk} = -e_{ijk} \omega_i$$

$$\omega_i = -e_{ijk} \Omega_{jk}$$

$\Omega :=$ infinitesimal
rotation tensor

Update orientation: 3

- To rotate an orientation:

$$\begin{aligned} g^{\text{new}} &= \mathbf{R} \cdot g^{\text{old}} \\ &= (\mathbf{I} + \mathbf{W}^*) \cdot g^{\text{old}}, \end{aligned}$$

or, if no “rigid body” spin ($W^g = 0$),

$$g^{\text{new}} = \left(\mathbf{I} + \sum_s \dot{\gamma}^s q^s \right) \cdot g^{\text{old}}$$

Note: more complex algorithm required for relaxed constraints.

Combining small rotations

- It is useful to demonstrate that a set of small rotations can be combined through addition of the skew-symmetric parts, given that rotations combine by (e.g.) matrix multiplication.
- This consideration reinforces the importance of using small strain increments in simulation of texture development.

Small Rotation Approximation

$$R_3 = R_2 R_1$$

$$\Leftrightarrow R_3 = (I + \dot{\gamma}_2 q_2)(I + \dot{\gamma}_1 q_1)$$

$$\Leftrightarrow R_{ik}^{(3)} = \left(\delta_{ij} + \dot{\gamma}^{(2)} q_{ij}^{(2)} \right) \left(\delta_{jk} + \dot{\gamma}^{(1)} q_{jk}^{(1)} \right)$$

$$\Leftrightarrow R_{ik}^{(3)} = \delta_{ij} \delta_{jk} + \delta_{ij} \dot{\gamma}^{(1)} q_{jk}^{(1)} + \delta_{jk} \dot{\gamma}^{(2)} q_{ij}^{(2)} + \underbrace{\dot{\gamma}^{(2)} q_{ij}^{(2)} \dot{\gamma}^{(1)} q_{jk}^{(1)}}_{\text{second order term}}$$

$$\approx R_{ik}^{(3)} = \delta_{ik} + \dot{\gamma}^{(1)} q_{ik}^{(1)} + \dot{\gamma}^{(2)} q_{ik}^{(2)}$$

$$\Leftrightarrow R_3 = I + \sum_i \dot{\gamma}^{(i)} q^{(i)}$$

Q.E.D.

Neglect this second order term for small rotations

Taylor Model: Reorientation in Tension

Note that these results have been tested in considerable experimental detail by Winther *et al.* at Risø; although Taylor's results are correct in general terms, significant deviations are also observed*.

Texture development = mix of $\langle 111 \rangle$ and $\langle 100 \rangle$ fibers

Initial configuration

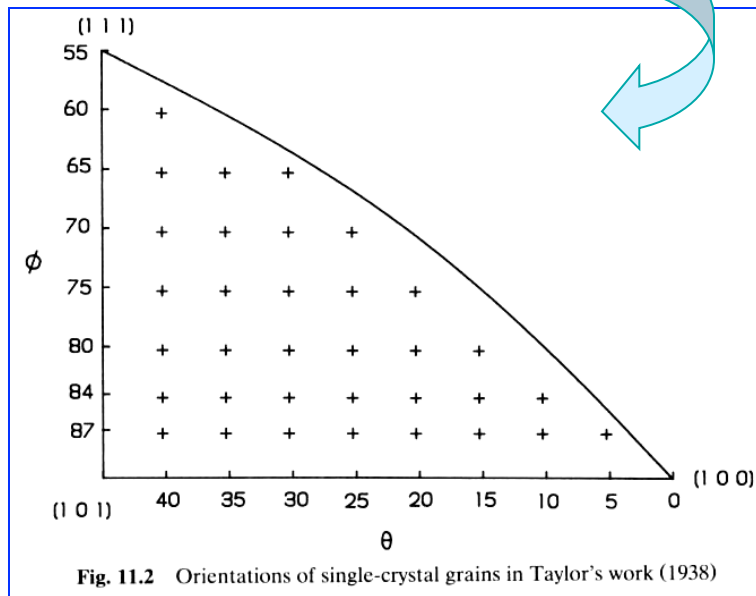

Final configuration, after 2.37% of extension

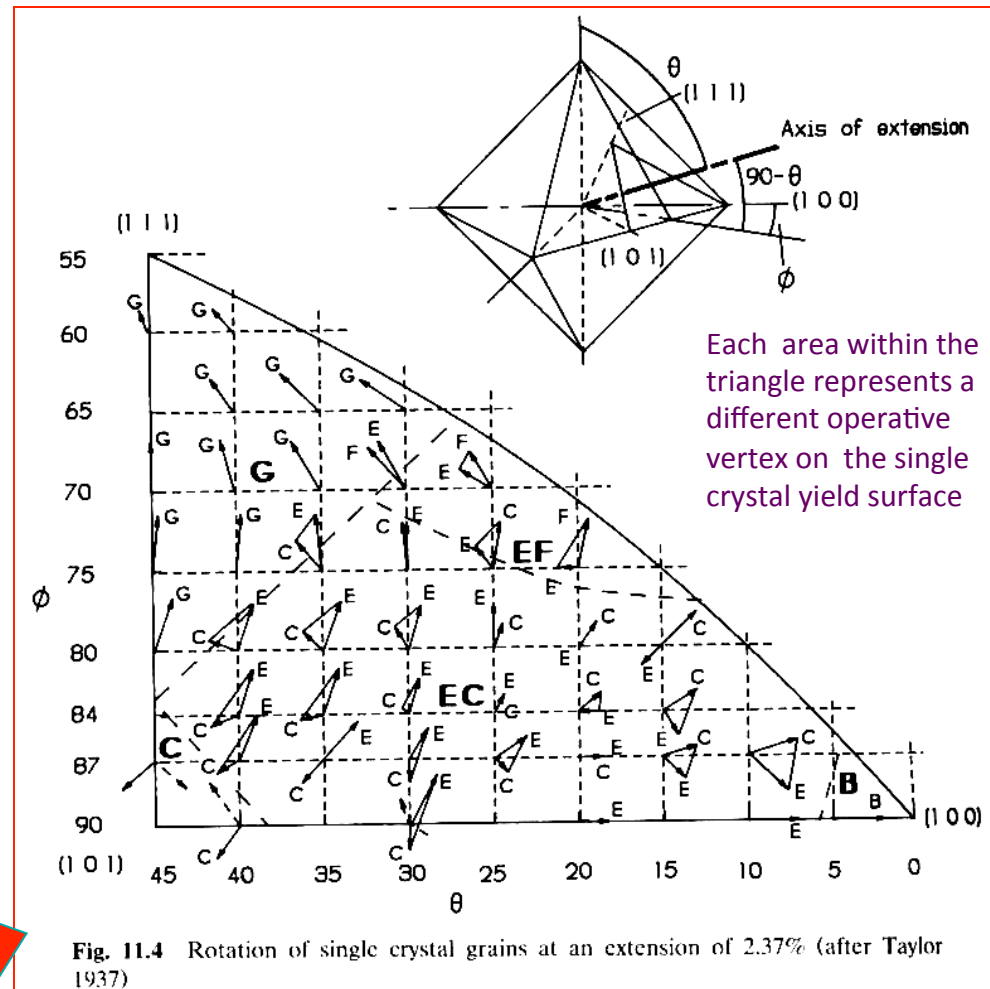

*Winther G., 2008, Slip systems, lattice rotations and dislocation boundaries, *Materials Sci Eng. A* **483**, 40-6

Final Texture

- It is not particularly clear from the previous figure but the Taylor theory (iso-strain) for uniaxial tension in fcc materials predicts that the tensile axis will move towards either the 111 or 100 corner. This means that the final texture is predicted to be a mix of $\langle 111 \rangle$ and $\langle 100 \rangle$ fibers. This is, in fact, what is observed experimentally.
- Contrast this result for the Taylor theory (iso-strain) with that of the single slip situation (previous lecture, iso-stress) in which the tensile axis ends up parallel to 112. Note that this requires two slip systems to be active, the primary and the conjugate. Thus the predicted iso-stress texture is a $\langle 112 \rangle$ fiber, which is *not* what is observed.

Taylor factor: multi-axial stress and strain states

- The development given so far needs to be generalized for arbitrary stress and strain states.
- Write the deviatoric stress as the product of a tensor with unit magnitude (in terms of von Mises equivalent stress) and the (scalar) critical resolved shear stress, τ_{crss} , where the tensor defines the multiaxial stress state associated with a particular strain direction, \mathbf{D} .

$$\mathbf{S} = \mathbf{M}(\mathbf{D}) \tau_{\text{crss}}.$$

- Then we can find the (scalar) Taylor factor, M , by taking the inner product of the stress deviator and the strain rate tensor:

$$\mathbf{S}:\mathbf{D} = \mathbf{M}(\mathbf{D}):\mathbf{D} \tau_{\text{crss}} = M \tau_{\text{crss}}.$$

- See p 336 of [Kocks] and the lecture on the Relaxed Constraints Model.

Summary

- Multiple slip is very different from single slip.
- Multiaxial stress states are required to activate multiple slip.
- For cubic metals, there is a finite list of such multiaxial stress states (56).
- Minimum (microscopic) slip (Taylor) is equivalent to maximum work (Bishop-Hill).
- Solution of stress state still leaves the “ambiguity problem” associated with the distribution of (microscopic) slips; this is generally solved by using a rate-sensitive solution.

Supplemental Slides

Self-Consistent Model

- Following slides contain information about a more sophisticated model for crystal plasticity, called the *self-consistent model*.
- It is based on a finding a mean-field approximation to the environment of each individual grain.
- This provides the basis for the popular code VPSC made available by Tomé and Lebensohn (Lebensohn, R. A. and C. N. Tome (1993). "A Self-Consistent Anisotropic Approach for the Simulation of Plastic-Deformation and Texture Development of Polycrystals - Application to Zirconium Alloys." *Acta Metallurgica et Materialia* **41** 2611-2624).

Kröner, Budiansky and Wu's Model

Taylor's Model

- compatibility across grain boundary
- violation of the equilibrium between the grains

Budiansky and Wu's Model

- Self-consistent model
- Ensures both compatibility and equilibrium conditions on grain boundaries
- Based on the Eshelby inclusion model

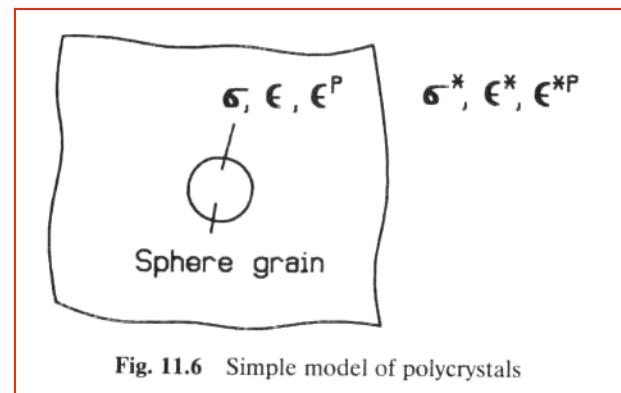

Fig. 11.6 Simple model of polycrystals

Kröner, Budiansky and Wu's Model

Khan & Huang

The model:

- ❖ Sphere (single crystal grain) embedded in a homogeneous polycrystal matrix.
- ❖ The grain and the matrix are elastically isotropic.

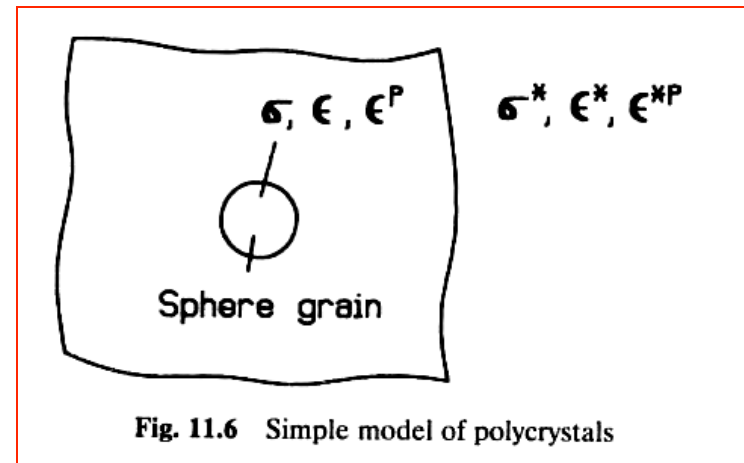

Fig. 11.6 Simple model of polycrystals

- ❖ Can be described by an elastic stiffness tensor C , which has an inverse C^{-1} .
- ❖ The matrix is considered to be infinitely extended.
- ❖ The overall quantities σ^* , ϵ^* and ϵ^{*P} are considered to be the average values of the local quantities σ , ϵ and ϵ^P over all randomly distributed single crystal grains.

Kröner, Budiansky and Wu's Model

The initial problem can be solved by the following approach

1 – split the proposed scheme into two other as follows

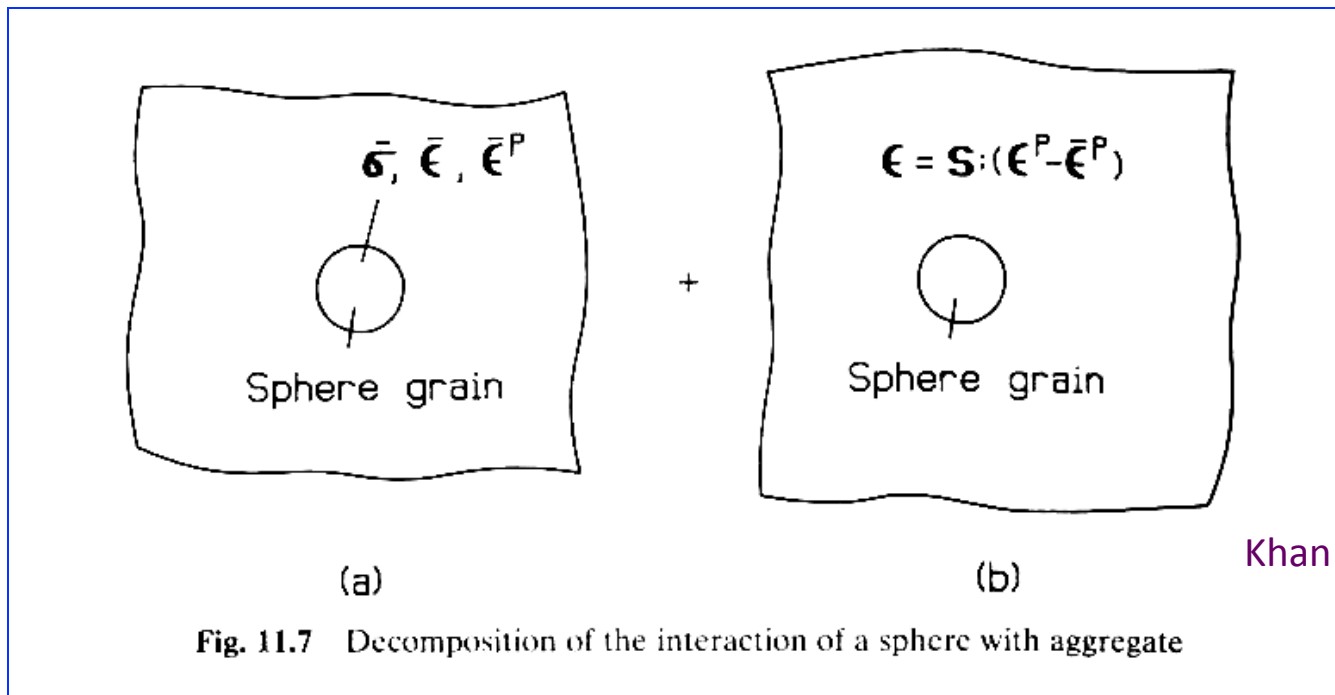

Kröner, Budiansky and Wu's Model

1.a – The aggregate and grain are subject to the overall quantities $\bar{\sigma}$, $\bar{\epsilon}$ and $\bar{\epsilon}^P$. In this case the total strain is given by the sum of the elastic and plastic strains:

$$\boldsymbol{\epsilon} = \mathbf{C}^{-1} : \bar{\boldsymbol{\sigma}} + \bar{\boldsymbol{\epsilon}}^P$$

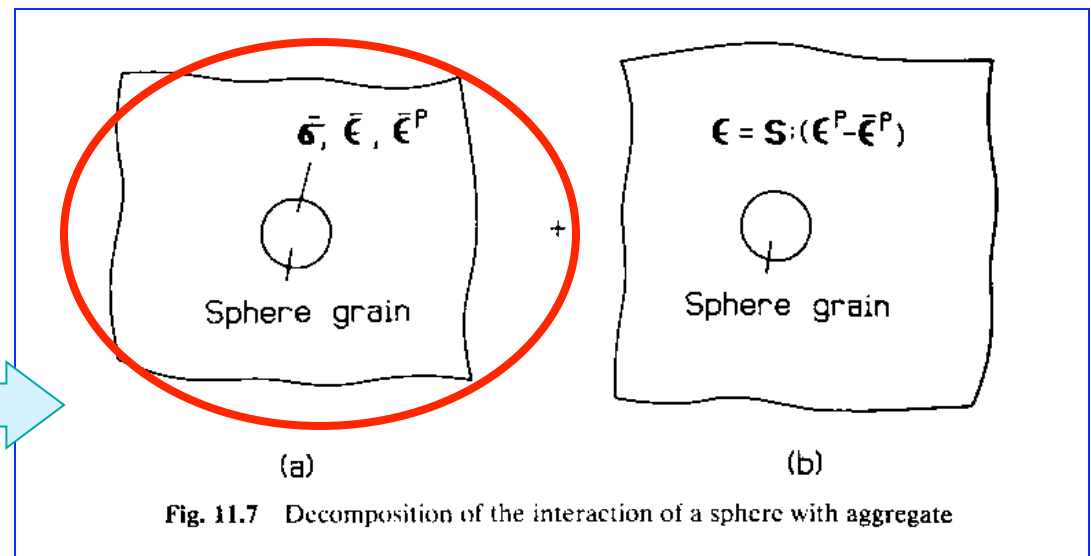
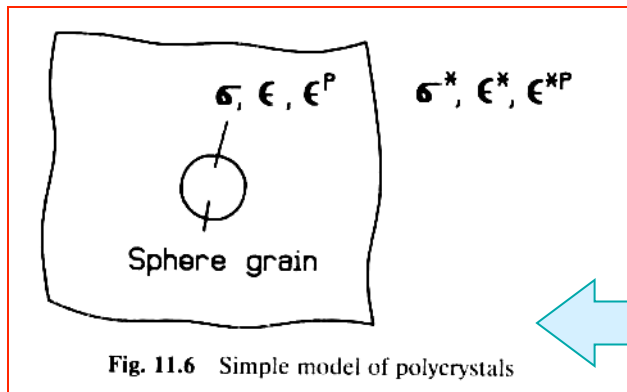

Kröner, Budiansky and Wu's Model

1.b – The sphere

$$\boldsymbol{\varepsilon}' = \boldsymbol{\varepsilon}^P - \bar{\boldsymbol{\varepsilon}}^P_{\text{composite}}$$

- ❖ has a stress-free transformation strain, $\boldsymbol{\varepsilon}'$, which originates in the difference in plastic response of the individual grain from the matrix as a whole.
- ❖ has the same elastic property as the aggregate
- ❖ is very small when compared with the aggregate (the aggregate is considered to extend to infinity)

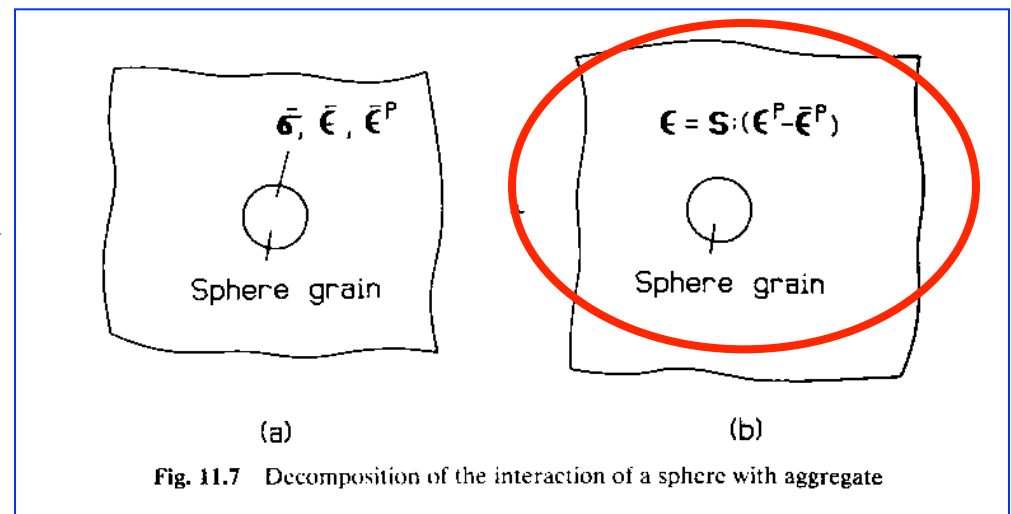
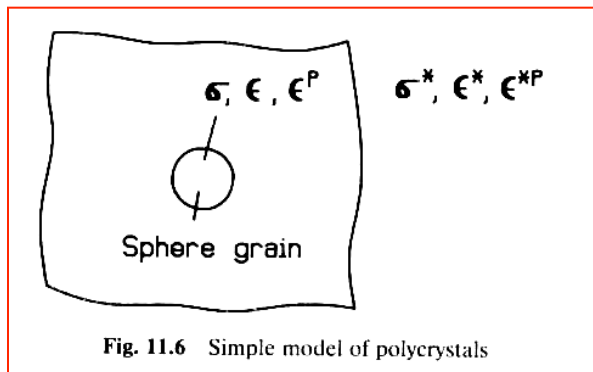

Kröner, Budiansky and Wu's Model

The strain inside the sphere due to the elastic interaction between the grain and the aggregate caused by ϵ' is given by

$$\epsilon = S : \epsilon' = S : (\epsilon^p - \bar{\epsilon}^p)$$

Where,

S is the Eshelby tensor (*not* a compliance tensor) for a sphere inclusion in an isotropic elastic matrix

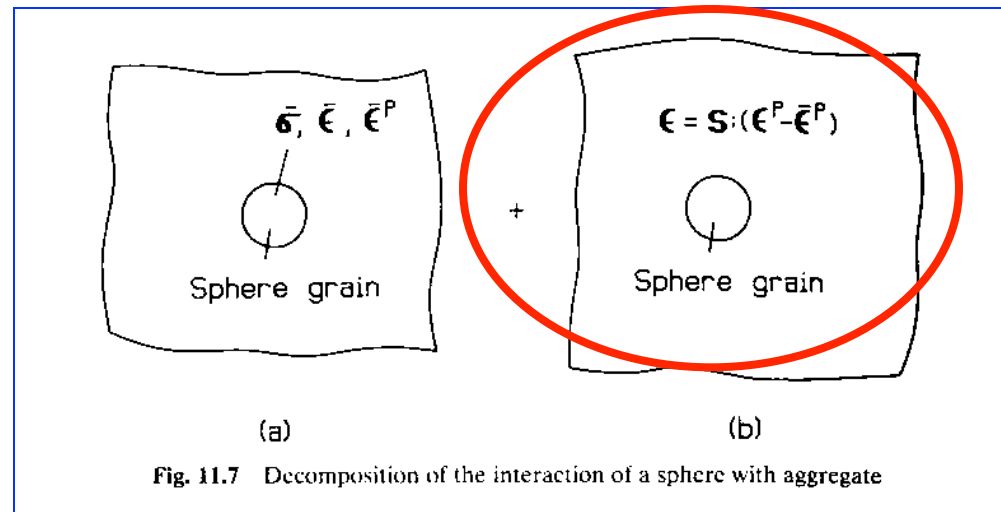

Kröner, Budiansky and Wu's Model

Then the actual strain inside the sphere is given by the sum of the two representations (1a and 1b) as follows

$$\boldsymbol{\varepsilon} = \mathbf{C}^{-1} : \bar{\boldsymbol{\sigma}} + \bar{\boldsymbol{\varepsilon}}^p + \mathbf{S} : (\boldsymbol{\varepsilon}^p - \bar{\boldsymbol{\varepsilon}}^p)$$

Given that,

$$\mathbf{S} : (\boldsymbol{\varepsilon}^p - \bar{\boldsymbol{\varepsilon}}^p) = \beta (\boldsymbol{\varepsilon}^p - \bar{\boldsymbol{\varepsilon}}^p)$$

where

$$\beta = \frac{2(4-5\nu)}{15(1-\nu)}$$

It leads to

$$\boldsymbol{\varepsilon} = \mathbf{C} : \bar{\boldsymbol{\sigma}} + \bar{\boldsymbol{\varepsilon}}^p + \beta (\boldsymbol{\varepsilon}^p - \bar{\boldsymbol{\varepsilon}}^p)$$

Kröner, Budiansky and Wu's Model

From the previous equation, it follows that the stress inside the sphere is given by

$$\begin{aligned}\sigma &= \mathbf{C} : \varepsilon^e = \mathbf{C} : (\varepsilon - \varepsilon^p) = \\ &= \bar{\sigma} - 2G(1 - \beta)(\varepsilon^p - \bar{\varepsilon}^p)\end{aligned}$$

Kröner, Budiansky and Wu's Model

In incremental form

$$\dot{\sigma} = \bar{\dot{\sigma}} - 2G(1 - \beta)(\dot{\varepsilon}^p - \bar{\dot{\varepsilon}}^p)$$

where

$$\begin{aligned}\bar{\sigma} &= (\sigma)_{\text{ave}}, & \bar{\dot{\sigma}} &= (\dot{\sigma})_{\text{ave}} \\ \bar{\varepsilon}^p &= (\varepsilon^p)_{\text{ave}}, & \bar{\dot{\varepsilon}}^p &= (\dot{\varepsilon}^p)_{\text{ave}}\end{aligned}$$

Equations

Slide 31: $\tau = m_{11}\sigma_{11} + m_{22}\sigma_{22} + m_{33}\sigma_{33} + (m_{12} + m_{21})\sigma_{12} + (m_{13} + m_{31})\sigma_{13} + (m_{23} + m_{32})\sigma_{23}$

SLIDE 34:

```
\begin{bmatrix} \tau_1 & \tau_2 & \tau_3 & \tau_4 & \tau_5 \\ m_{11} & m_{22} & m_{33} & m_{12} & m_{13} \\ m_{12} & m_{21} & m_{31} & m_{22} & m_{23} \\ m_{13} & m_{31} & m_{32} & m_{23} & m_{33} \\ m_{22} & m_{33} & m_{12} & m_{21} & m_{31} \end{bmatrix} = \begin{bmatrix} m_{11} & m_{22} & m_{33} & m_{12} & m_{13} \\ m_{12} & m_{21} & m_{31} & m_{22} & m_{23} \\ m_{13} & m_{31} & m_{32} & m_{23} & m_{33} \\ m_{22} & m_{33} & m_{12} & m_{21} & m_{31} \\ m_{23} & m_{32} & m_{13} & m_{31} & m_{22} \end{bmatrix}
```

```
\begin{bmatrix} -C & B & F & G & H \\ m_{22} & m_{33} & m_{12} & m_{21} & m_{31} \\ m_{23} & m_{32} & m_{13} & m_{31} & m_{22} \\ m_{12} & m_{21} & m_{31} & m_{22} & m_{23} \\ m_{13} & m_{31} & m_{32} & m_{23} & m_{33} \\ m_{22} & m_{33} & m_{12} & m_{21} & m_{31} \end{bmatrix}
```

SLIDE 37

$\Delta w = \sigma_{11} d\epsilon_{11} + \sigma_{22} d\epsilon_{22} + \sigma_{33} d\epsilon_{33} + 2\sigma_{12} d\epsilon_{12} + 2\sigma_{13} d\epsilon_{13} + 2\sigma_{23} d\epsilon_{23}$

SLIDE 53: $\Omega_{ij}^{(\alpha)} = \frac{1}{2} (b_i^{(\alpha)} n_j^{(\alpha)} - b_j^{(\alpha)} n_i^{(\alpha)})$