

Representation of Orientation and Disorientation Data for Cubic, Hexagonal, Tetragonal and Orthorhombic Crystals

BY A. HEINZ AND P. NEUMANN

Max-Planck-Institut für Eisenforschung, 4000 Düsseldorf 1, Germany

(Received 10 December 1990; accepted 11 June 1991)

Abstract

A convenient method for the description of orientation data for cubic, hexagonal, tetragonal and orthorhombic crystals is given. The method can also be used for the representation of disorientation data, where disorientations between any two crystals of the specified symmetry lattices are considered. It is based on the quaternion formalism introduced into the discussion of orientations and disorientations by Grimmer [*Acta Cryst.* (1974), **A30**, 685–688], Frank [(1987). *Proc. Int. Conf. on Texture of Materials 8 (INCOTOM 8)*, Santa Fé, USA, pp. 3–13] and others. Since orientations and disorientations can be interpreted as rotations which in turn can be represented by only three parameters a vector description is used. These vectors span a rotation space corresponding to the usual space of Eulerian angles. It is called Rodrigues vector space [Rodrigues (1840). *J. Math. Pure Appl.* **5**, 380–440; Becker & Panchanadeeswaran (1989). *Text. Microstruct.* **10**, 167]. The direction of a Rodrigues vector is parallel to the rotation axis and its length is $\tan(\theta/2)$, where θ describes the rotation angle. A method for selecting a unique representative out of the numerous symmetrically equivalent Rodrigues vectors is given. Since these selection rules depend on the symmetry of the crystal lattices considered they yield compact domains in the Rodrigues vector space which are typical for each type of lattice or lattice pair. These domains are always bounded by planes. Frank (1987) called them fundamental zones and described them for the orientations of cubic, hexagonal and orthorhombic crystals.

1. Introduction

Since orientations and disorientations can be interpreted as rotations the representation of (dis)orientations is closely related to the representation of rotations. One of the most widely used methods is that of the three Eulerian angles φ_1 , φ_2 and Φ , but there are two major disadvantages:

1. Each orientation is represented by three points in the usual Eulerian angle space (EAS). A unique representation would only be possible in a subspace having curved boundaries.

2. There is a degeneracy of the invariant volume element at $\Phi = 0$. All points $\varphi_1 + \varphi_2 = \text{constant}$, $\Phi = 0$

represent the same orientation. Some papers have dealt with avoiding this degeneracy by various modifications of the Euler representation [see for example Helmig, Matthies & Vinel (1988); Bunge (1988); Matthies, Helmig & Kunze (1990)].

Among the other methods of representing orientation data the vector description due to Rodrigues (1840) seems to be the most favourable one. The advantages of this method are discussed in detail by Frank (1987) and Neumann (1990). Since this vector method yields a convenient and unique description of orientations and disorientations we decided to adopt it for the representation of (dis)orientation data of cubic, hexagonal, tetragonal and orthorhombic crystals. Gertsman (1989) used these vectors for calculating the coincidence disorientations of cubic, hexagonal and tetragonal crystals, but without referring to their fundamental meaning in the representation of (dis)orientation data.

Since lattice symmetry allows the description of an (a dis)orientation in many different ways a procedure is formulated in this paper for obtaining a unique representative out of the symmetrically equivalent vectors. This procedure is correlated to the quaternion formalism [see for example DuVal (1964)] which was first used by Grimmer (1974) for the description of disorientations of cubic crystals. The restrictions leading to a unique representative can be interpreted geometrically as planes bounding a compact volume in the Rodrigues vector space. These domains correspond to the commonly used volume in the space of Eulerian angles. Since the restrictions used in our formalism are characteristic for the symmetry elements of the point group in question, a special cell can be found for every point group or combination of point groups, respectively. Bonnet (1980) was the first to formulate these characteristic restrictions for the disorientations of cubic, hexagonal, tetragonal and orthorhombic crystal symmetry. On the other hand, in this paper he neither mentioned their geometrical meaning nor that they are valid for orientations as well.

2. Definition of orientations and disorientations

In order to define the orientation of an object, an orthonormal and right-handed frame is attached to

it. Then the orientation can be described in terms of the coordinate transformation that transforms the axes of the object frame onto those of a second, external, orthonormal and right-handed reference frame (RF). Since orthonormal frames are chosen this transformation is a rotation, so the orientation can be represented by the appropriate rotation matrix \mathbf{D}_1 .

In the case of a single crystal the object in question is the Bravais lattice. For cubic crystals the axes of the orthonormal frame attached to the Bravais cell (crystal frame, CF) are chosen to be parallel to the edges of the cube. For a hexagonal, tetragonal or orthorhombic lattice the first axis of the CF is parallel to the a axis and the third axis is parallel to the c axis of the Bravais cell. Obviously, the specification of the matrix \mathbf{D}_1 is not yet unique since a number of symmetrically equivalent CF are possible. The corresponding rotation matrices are

$$\mathbf{D}_i = \mathbf{D}_1 \mathbf{S}_i, \quad i = 1, \dots, n; \quad \mathbf{S}_1 = \mathbf{E}, \quad (1)$$

where \mathbf{S}_i describes one of the n symmetry operations belonging to the crystal class in question. From these n symmetrically equivalent rotations \mathbf{D}_i the one which has the smallest rotation angle is chosen as the representative for describing the orientation. It should be emphasized that this convention has no physical relevance at all. Mathematically it is the simplest way to obtain a unique description of an orientation. On the other hand, this convention leads to the most useful way of describing orientation data.

The definition of a disorientation between two objects can now be formulated analogously. If there are frames attached to the two objects then the transformation of one of the frames onto the other can be taken as a description of the disorientation. In the case of crystals, this method again does not provide a unique representative. This time there are $n \times m$ matrices that are symmetrically equivalent, namely

$$\begin{aligned} \mathbf{D}_{ij} &= \mathbf{S}_i^a \mathbf{D}_1 \mathbf{S}_j^b, \quad i = 1, \dots, n, \quad j = 1, \dots, m, \\ \mathbf{S}_1^a &= \mathbf{E} = \mathbf{S}_1^b, \end{aligned} \quad (2)$$

where \mathbf{S}^a runs through the n symmetries of the first crystal, named A , and \mathbf{S}^b runs through the m symmetries of crystal B . If crystals of the same crystal structure are considered it is physically not relevant whether the lattice of crystal A is mapped onto that of crystal B or *vice versa*. As a result inverse rotations \mathbf{D}^{-1} are allowed this time too and the number of equivalent rotations doubles to $2n \times m$. That is true for example in the case of an investigation of grain boundaries in a single-phase alloy. If phase boundaries in a multiphase alloy are investigated it must be distinguished whether the considered rotation transforms the lattice of crystal A onto that of crystal B or *vice versa*. So we decided to adopt the following convention. If disorientations between non-identical

crystal structures are considered then the unique representative should be taken from those rotations that transform the lattice with the lower symmetry onto that with the higher symmetry.

Neumann (1990) showed that a unique representative can be selected by requiring that the rotation angle is as small as possible and that the rotation axis is lying in the standard stereographic triangle of the lattice in question. Here the proof will be given in terms of the matrix notation of (1) and (2), but for a more general case, where the m symmetries \mathbf{S}^b are a subgroup of the n symmetries \mathbf{S}^a .

The rotation angle θ_A of a matrix \mathbf{A} can be found as

$$\cos(\theta_A) = [\text{tr}(\mathbf{A}) - 1]/2$$

where $\text{tr}(\mathbf{A})$ is the trace of \mathbf{A} . Any of the $n \times m$ matrices \mathbf{D}_{ij} can be written as

$$\begin{aligned} \mathbf{D}_{ij} \mathbf{S}_i^a \mathbf{D}_1 \mathbf{S}_j^b &= [(\mathbf{S}_j^b)^{-1} \mathbf{S}_j^b] \mathbf{S}_i^a \mathbf{D}_1 \mathbf{S}_j^b \\ &= (\mathbf{S}_j^b)^{-1} (\mathbf{S}_j^b \mathbf{S}_i^a) \mathbf{D}_1 \mathbf{S}_j^b \\ &= (\mathbf{S}_j^b)^{-1} (\mathbf{S}_k^a \mathbf{D}_1) \mathbf{S}_j^b \\ &= (\mathbf{S}_j^b)^{-1} (\mathbf{D}_k) \mathbf{S}_j^b. \end{aligned}$$

This equation read from left to right means that any matrix \mathbf{D}_{ij} is a member of a class that is obtained by transforming a suitably chosen matrix \mathbf{D}_k by one of the m symmetries \mathbf{S}^b . Each class consists of m elements and, since \mathbf{D}_k was obtained as $\mathbf{S}_k^a \mathbf{D}_1$, there are in general n such classes. Moreover, since $\text{tr}(\mathbf{AB}) = \text{tr}(\mathbf{BA})$ it follows that $\text{tr}[(\mathbf{S}_j^b)^{-1} \mathbf{D}_k \mathbf{S}_j^b] = \text{tr}[\mathbf{S}_j^b (\mathbf{S}_j^b)^{-1} \mathbf{D}_k] = \text{tr}(\mathbf{D}_k)$, which means that all members of a single class have the same rotation angle. Since the upper bound for the rotation angle was already fixed by $\mathbf{S}_i^a \mathbf{D}_1$, this upper bound is not influenced by multiplying $\mathbf{S}_i^a \mathbf{D}_1$ with \mathbf{S}_j^b when \mathbf{S}^b is a subgroup of \mathbf{S}^a .

Now let \mathbf{D} be a member of the class with smallest rotation angle and let \mathbf{D}_j be this whole class:

$$\mathbf{D}_j = (\mathbf{S}_j^b)^{-1} \mathbf{D} \mathbf{S}_j^b.$$

Then the rotation axis of any member is $\mathbf{d}_j = (\mathbf{S}_j^b)^{-1} \mathbf{d}$, where \mathbf{d} is the rotation axes of \mathbf{D} . Thus the axes of all \mathbf{D}_j are obtained by transforming one of them with all symmetries \mathbf{S}_j^b . Only one of these axes lies in the standard stereographic triangle related to the symmetries of \mathbf{S}^b . Thus the group with the lower symmetry (less elements, \mathbf{S}^b in our case) defines the adequate standard stereographic triangle and the group with higher symmetry (more elements, \mathbf{S}^a) fixes the maximum reduced rotation angle.

Since the above discussion is independent of the explicit groups of symmetries the mentioned arguments hold for disorientations too. In this case $\mathbf{S}^a = \mathbf{S}^b$, which means that the unique representatives have the same maximum reduced rotation angle as is valid for orientations and their rotation axis is lying in the

standard stereographic triangle defined by the particular crystal symmetry.

3. Quaternions and Rodrigues vectors

As pointed out, (dis)orientations can be described as rotations. There is a two-to-one homomorphism between the group of unit quaternions and the three-dimensional rotation group $SO(3)$ (van der Waerden, 1932). A unit quaternion \mathbf{q} is an ordered set of four real numbers of the following form

$$\mathbf{q} = (q_0; q_1; q_2; q_3), \quad \text{satisfying} \quad \sum_{i=0}^3 q_i^2 = 1. \quad (3)$$

The rotation matrix belonging to $\pm \mathbf{q}$ is obtained as

$$\begin{pmatrix} q_0^2 + q_1^2 - q_2^2 - q_3^2 & 2(q_1q_2 - q_0q_3) & 2(q_1q_3 + q_0q_2) \\ 2(q_1q_2 + q_0q_3) & q_0^2 - q_1^2 + q_2^2 - q_3^2 & 2(q_2q_3 - q_0q_1) \\ 2(q_1q_3 - q_0q_2) & 2(q_2q_3 + q_0q_1) & q_0^2 - q_1^2 - q_2^2 + q_3^2 \end{pmatrix}.$$

This can be compared to the rotation matrix that one obtains from a rotation axis $\mathbf{n} = (n_1, n_2, n_3)$; $|\mathbf{n}| = 1$ and a rotation angle θ

$$\begin{pmatrix} (1-a)n_1^2 + 1 & (1-a)n_1n_2 - n_3b & (1-a)n_1n_3 + n_2b \\ (1-a)n_1n_2 + n_3b & (1-a)n_2^2 + a & (1-a)n_2n_3 - n_1b \\ (1-a)n_1n_3 - n_2b & (1-a)n_2n_3 + n_1b & (1-a)n_3^2 + a \end{pmatrix}$$

where $a = \cos(\theta)$ and $b = \sin(\theta)$. One can easily verify that

$$\pm \mathbf{q} = \pm [\cos(\theta/2); \sin(\theta/2)\mathbf{n}_1; \sin(\theta/2)\mathbf{n}_2; \sin(\theta/2)\mathbf{n}_3].$$

By this relation and by the multiplication rule for matrices one easily finds the multiplication law for quaternions

$$\mathbf{qp} = \begin{cases} q_0p_0 - q_1p_1 - q_2p_2 - q_3p_3, \\ q_0p_1 + q_1p_0 + q_2p_3 - q_3p_2, \\ q_0p_2 - q_1p_3 + q_2p_0 + q_3p_1, \\ q_0p_3 + q_1p_2 - q_2p_1 + q_3p_0 \end{cases}$$

since \mathbf{q} can be written as

$$\mathbf{q} = (q_0; \mathbf{q}) \quad (4)$$

$$(\mathbf{qp})_0 = (q_0p_0 - \mathbf{qp}) \quad (5)$$

$$(\mathbf{qp}) = q_1\mathbf{p} + p_1\mathbf{q} + \mathbf{q} \times \mathbf{p}. \quad (6)$$

The quaternion description allows some insight into the character of rotations. From (3), a rotation can be interpreted as a surface point of the four-dimensional unit sphere S^4 . The inverse of \mathbf{q} is obtained by changing the sign of \mathbf{q} . Furthermore, it is possible to define a distance of two rotations, \mathbf{q} and \mathbf{p} , by using the rotation angle of the interconnecting rotation $\mathbf{r} = \mathbf{qp}^{-1}$.

The Rodrigues vector space introduced by Rodrigues (1840) [see also Frank (1987) and Neumann (1990)] is now defined by reducing the four components of a quaternion \mathbf{q} to the three

components of a Rodrigues vector \mathbf{d} according to

$$\mathbf{d} := (1/q_0)(q_1; q_2; q_3) = \tan(\theta/2)\mathbf{n}, \quad |\mathbf{n}| = 1, \quad (7)$$

where \mathbf{n} is the rotation axis and θ is the rotation angle. This is equivalent to a geodesic projection of S^4 onto R^3 . The great advantage of the new method compared to the usual representation in the space of Eulerian angles is the fact that there is a one-to-one relation between orientations and their representation. In the usual Eulerian angle space this does not hold. As already mentioned, a single orientation is usually represented by three different points in the Eulerian angle space, each point lying in another subspace. These three subspaces are equivalent to each other with respect to cubic symmetry. Obviously, the reason is that these three subspaces fit together to form a cube. If all cubic symmetries were used one would end up at one of these three subspaces only. However, these are not bounded by planes but by curved surfaces. The other disadvantage of the Eulerian representation, namely the degeneration of definite orientations from points to lines, is avoided in the Rodrigues vector space method too.

As Neuman (1990) pointed out, an ideal fibre texture is always represented by a straight line in the cubic orientation space (COS) defined by the Rodrigues vector method. A fibre texture is described by a set of orientations obeying

$$\mathbf{r}(\omega) = \mathbf{pq}(\omega, \mathbf{n}), \quad -\pi \leq \omega \leq \pi.$$

Here $\mathbf{p}(\omega, \mathbf{n})$ are all rotations about a fixed rotation axis \mathbf{n} with rotation angle $\omega \in [-\pi, \pi]$ and \mathbf{q} is an arbitrary orientation. These orientations are represented by a hypercircle on S^4 . Since the Rodrigues representation is a geodesic projection this hypercircle is projected onto a straight line in R^3 . Moreover, for any type of crystal lattice, all bounding surfaces introduced by symmetries are planes in Rodrigues vector space. This result is again a direct consequence of the geodesic nature of Rodrigues vector space.

4. Orientations and disorientations of cubic crystals

The point group describing cubic lattice is

$$m\bar{3}m, \text{ extended: } \frac{4}{m}\bar{3}\frac{2}{m} \Leftrightarrow O_h$$

in Schönflies notation

(see Birss, 1964). This group consists of 48 symmetry operations which can be generated by a set of three matrices. A set of generators is not unique and can be chosen for example as σ^1 , σ^7 and σ^9 . These can be written as

$$\sigma^1 = \begin{pmatrix} \bar{1} & 0 & 0 \\ 0 & \bar{1} & 0 \\ 0 & 0 & \bar{1} \end{pmatrix}; \quad \sigma^7 = \begin{pmatrix} 0 & 1 & 0 \\ \bar{1} & 0 & 0 \\ 0 & 0 & 1 \end{pmatrix}; \quad \sigma^9 = \begin{pmatrix} 0 & 1 & 0 \\ 0 & 0 & 1 \\ 1 & 0 & 0 \end{pmatrix}.$$

Here σ^1 is the inversion I , σ^7 is a fourfold rotation axis parallel to $[001]$ and σ^9 is a threefold rotation axis parallel to $[111]$. Since σ^1 is an improper rotation [$\det(\sigma^1) = -1$] one half of the elements of $m\bar{3}m$ are proper and the other half are improper rotations. As there is no reasonable way to define a rotation angle of an improper rotation these improper rotations are replaced by their product with σ^1 . Since the resulting symmetries are already present among the proper rotations the order of the group is halved. Thus the point group of interest is 432 instead of $m\bar{3}m$. That group is generated by σ^7 and σ^9 . The corresponding quaternions are $(2^{1/2}/2, 0, 0, 2^{1/2}/2)$ and $(1/2)(1, 1, 1, 1)$. These quaternions can be used to generate all proper symmetry operations of 432 except of the identity $(1, 0, 0, 0)$. With the aid of these 24 symmetries one can easily produce the 24 cubic equivalent quaternions of a given quaternion $q = (q_0; q_1; q_2; q_3)$ that describes the orientation of a cubic crystal. A unique representative of these 24 quaternions is found by taking the one with the smallest rotation angle. The procedure of finding the correct quaternion among the cubic equivalent ones is called its cubic reduction. It is described in detail by Grimmer (1974). The demand for the smallest rotation angle is equivalent to the condition that the first component of the resulting quaternion is largest. If this requirement is written down for all cubic equivalent quaternions the following inequalities are found:

$$(2^{1/2} - 1)q_0 \geq \pm q_i, \quad i = 1, 2, 3$$

and

$$q_0 \geq \pm q_1 \pm q_2 \pm q_3.$$

Here all sign changes are allowed. For the Rodrigues vectors this means that

$$(2^{1/2} - 1) \geq \pm d_i, \quad i = 1, 2, 3 \quad (8)$$

$$1 \geq \pm d_1 \pm d_2 \pm d_3. \quad (9)$$

The geometrical interpretation of inequality (8) is as follows. The cubic reduced unique Rodrigues vectors of any cubic orientation end within a cube in the Rodrigues vector space. The length of its edges is $(2^{1/2} - 1)$. Inequality (9) means that this cube is truncated at its corners by (111) -type planes. These planes have a distance of $1/3^{1/3}$ from the origin of the Rodrigues vector space. Thus the truncated cube has six octagonal side faces lying perpendicular to the fourfold axes and eight smaller triangular faces lying perpendicular to the threefold axes. This domain is called cubic orientation space. It is plotted as a stereo pair in Fig. 1. Since the length of a Rodrigues vector is correlated to the rotation angle one can easily prove that the maximum rotation angle necessary for the description of cubic orientations is 62.80° , a result that was obtained by several other authors using different methods (Handscomb, 1958; Mackenzie,

1958; Grimmer, 1974). That maximum rotation angle belongs, for example, to the Rodrigues vector $(2^{1/2} - 1, 2^{1/2} - 1, 3 - 2 \times 2^{1/2})$ which has a length of $(23 - 16 \times 2^{1/2})$. This orientation is more commonly described as a 90° rotation about $[1, 1, 0]$. This does not agree with the results of Bonnet (1980), who found a maximum reduced rotation angle of 62.80° for the vector $(1, 1, 2^{1/2} - 1)$. The length of that vector is $(5 - 2 \times 2^{1/2})$ yielding a rotation angle 111.68° . This seems to be due to a printer's error since the latter Rodrigues vector is printed several times in Bonnet's tables where it should not be found.

In the case of cubic disorientations one has to consider all 2×24^2 cubic equivalent quaternions that can be calculated according to (2). As shown in § 2 a unique representative can be selected from these by requiring that the rotation angle is as small as possible and that the rotation axis lies in the standard stereographic triangle of the cubic lattice. Thus for the cubic disorientations there are additional restrictions describing the fact that the rotation axis is in the standard stereographic triangle:

$$d_1 \geq d_2 \geq d_3 \geq 0. \quad (10)$$

These additional inequalities restrict the cubic disorientation space to the domain plotted in Fig. 2. For clearness the part of the cubic orientation space that lies in the first octant of Rodrigues vector space is plotted too. Here one can see explicitly that the maximum rotation angle necessary for the description of cubic disorientations is again 62.80° .

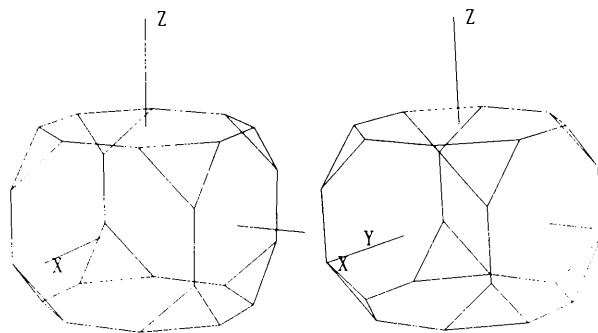

Fig. 1. Cubic orientation space.

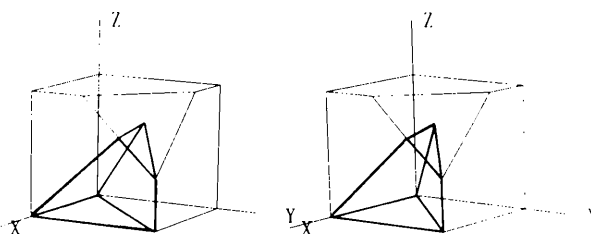

Fig. 2. Cubic disorientation space.

Since the three-dimensional plots of the cubic orientation/disorientation space are difficult to evaluate quantitatively a second method of plotting the orientation vectors is used applying equidistant sections through the cubic orientation or disorientation space. For this purpose, sections of equal thickness perpendicular to the d_3 axis are plotted consecutively together with the points contained within them. The cubic orientation and the cubic disorientation space of Figs. 1 and 2 are plotted in this manner in Figs. 3 and 4 respectively. As already pointed out, the restrictions leading to the compact domains for any point group or pair of point groups are always linear, in other words, the domains are always bounded by planes. Thus this sliced way of representing orientation and disorientation data can easily be applied for any crystal system.

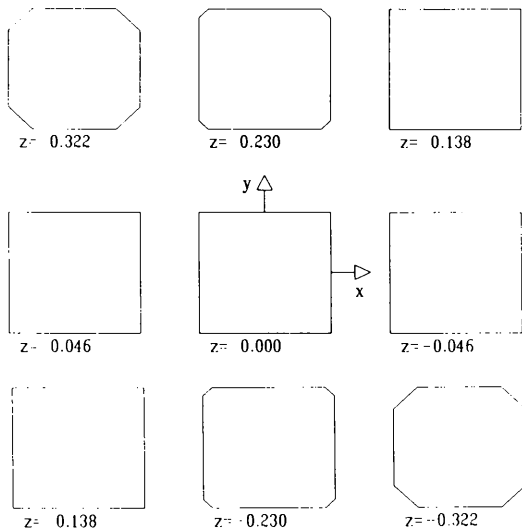

Fig. 3. Equidistant sections perpendicular to the d_3 axis through the cubic orientation space of Fig. 1.

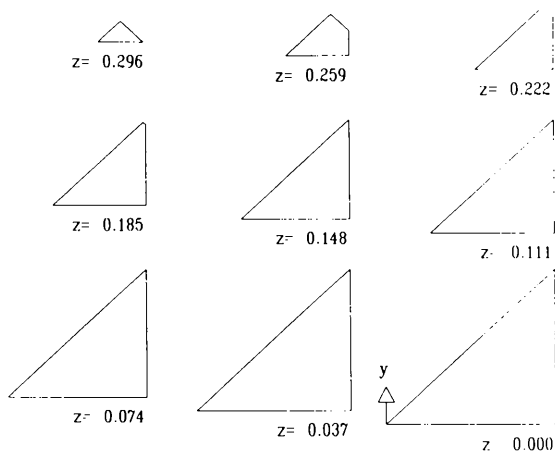

Fig. 4. Equidistant sections perpendicular to the d_3 axis through the cubic disorientation space of Fig. 2.

5. Orientations and disorientations of hexagonal closed-packed crystals

The methods for describing cubic orientation and disorientation data are well developed. Especially the method of orientation distribution functions (ODF) which is due to Bunge (1982*a, b*, 1987) and Hansen, Pospiech & Lücke (1978) has widespread use in texture analysis. For hexagonal crystals these methods are less elaborated. Usually the orientation data obtained in texture analysis are plotted as pole figures. Morris & Heckler (1969) were the first to plot a hexagonal ODF in the space of Eulerian angles. Haessner & Schröder (1977) used this method for calculating inverse pole figures. Bunge (1982*a, b*) described the symmetry elements in the space of Eulerian angles that are caused by hexagonal crystal structure and a number of different symmetries of the specimen. Since all the mentioned methods are more or less analogous to those used for cubic crystals, they have the same disadvantages. Moreover, there is no method in use, known to the authors so far, for plotting unique disorientation data of non-cubic crystals. Thus the Rodrigues vector space method is applied here to orientations and disorientations of hexagonal crystals.

The point group describing a h.c.p. material is

$$6/mmm, \text{ extended: } \frac{6}{m} \frac{2}{m} \frac{2}{m} \Leftrightarrow D_{6h}$$

in Schönflies notation.

This group is spanned by the generating matrices σ^1 , σ^2 , σ^3 and σ^6 . These are

$$\sigma^1 = I, \quad \sigma^2 = \begin{pmatrix} \bar{1} & 0 & 0 \\ 0 & 1 & 0 \\ 0 & 0 & \bar{1} \end{pmatrix},$$

$$\sigma^3 = \begin{pmatrix} \bar{1} & 0 & 0 \\ 0 & \bar{1} & 0 \\ 0 & 0 & 1 \end{pmatrix}, \quad \sigma^6 = \begin{pmatrix} \bar{a} & b & 0 \\ \bar{b} & \bar{a} & 0 \\ 0 & 0 & 1 \end{pmatrix}$$

where $a = \frac{1}{2}$ and $b = 3^{1/2}/2$.

σ^2 and σ^3 are twofold rotation axes about [010] and [001] respectively. σ^6 is a threefold rotation about

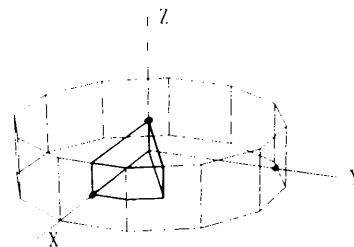

Fig. 5. Hexagonal orientation and disorientation space. The solid circles mark the intersection points of the axes with the surface of the disorientation space.

[001]. The subgroup of proper rotations is the point group 622. The quaternions related to the proper rotations are (same order as above) $(0, 0, 1, 0)$, $(0, 0, 0, 1)$, $(\frac{1}{2}, 0, 0, 3^{1/2}/2)$. From these the twelve quaternions related to the proper symmetries of $6/mmm$ can easily be calculated. Now the procedure is analogous to that of the cubic case. The condition that the unique disorientation vector corresponds to a quaternion with maximum first component q_0 yields the following inequalities for the Rodrigues vectors:

$$\begin{aligned} 1 &\geq |d_i|, & i = 1, 2, 3 \\ 1 &\geq \pm(a \pm bd_3) \\ 1 &\geq \pm(ad_1 \pm bd_2) \\ 1 &\geq \pm(bd_1 \pm ad_2) \\ 1 &\geq \pm(b \pm ad_3). \end{aligned}$$

Here all sign changes are allowed again. From these restrictions the hexagonal orientation space can be constructed. It is plotted in Fig. 5. It is a prism with a symmetric dodecagonal base and top surface. The side faces are squares. The height of the prism is $h = 2(2 - 3^{1/2})$; i.e. $|d_3| \leq (2 - 3^{1/2})$. The corners of the top surface lying in the first octant are

$$\begin{aligned} &[1, (2 - 3^{1/2}), (2 - 3^{1/2})], \\ &[(3^{1/2} - 1), (3^{1/2} - 1), (2 - 3^{1/2})], \\ &[(2 - 3^{1/2}), 1, (2 - 3^{1/2})]. \end{aligned}$$

For symmetry reasons all the other corners can be found easily.

As already pointed out the longest vector lying in the orientation space covers the largest rotation angle necessary for the description of an (a dis)orientation. Therefore using one of the above corners it can be proved very easily that the maximum rotation angle for hexagonal crystals is $93 \cdot 84^\circ$.

In analogy to the cubic case, hexagonal disorientations can be reduced to a Rodrigues vector that covers a minimal rotation angle and has a rotation axis lying in the hexagonal standard stereographic triangle. This yields two new restriction, namely

$$0 \leq d_2 \leq (1/3^{1/2})d_1, \quad 0 \leq d_3.$$

The resulting hexagonal disorientation space is plotted into the hexagonal orientation space of Fig. 5.

6. Orientations and disorientations of tetragonal crystals

The point group of the tetragonal crystal lattice is $4/mmm$. It is generated by the matrices σ^1 , σ^2 and σ^7 . These have already been described in the preceding sections. The subgroup of proper rotations is 422. From the related quaternions one can construct all eight symmetry elements of 422. With the aid of this quaternion the restrictions for the tetragonal

orientation space are calculated to be

$$\begin{aligned} 1 &\geq \pm|d_i|, & i = 1, 2, 3 \\ (2^{1/2} - 1) &\geq \pm d_3, & 2^{1/2} \geq \pm d_1 \pm d_2. \end{aligned}$$

Here all combinations of signs are allowed. From these inequalities the tetragonal orientation space can be constructed. It is plotted in Fig. 6. It is a prism with a symmetric octagonal base and a height $h = 2(2^{1/2} - 1)$; i.e. $|d_3| \leq (2^{1/2} - 1)$. The corners of the top surface lying in the first octant are

$$[1, (2^{1/2} - 1), (2^{1/2} - 1)], \quad [(2^{1/2} - 1), 1, (2^{1/2} - 1)].$$

All other corners can be found by symmetry. Since the longest tetragonal reduced Rodrigues vector corresponds to the largest rotation angle necessary in the description of tetragonal orientations one can easily verify that this angle is $98 \cdot 42^\circ$.

The tetragonal disorientation space is found by using additional restrictions describing the fact that the rotation axis should lie in the tetragonal standard stereographic triangle. These restrictions are

$$d_3 \geq 0, \quad d_1 \geq d_2 \geq 0.$$

The tetragonal disorientation space is plotted in the tetragonal orientation space of Fig. 6.

7. Orientations and disorientations of orthorhombic crystals

The point group of the orthorhombic crystal lattice is mmm . It is generated by σ^1 , σ^2 and σ^3 . The proper subgroup of mmm is 222. Using the same procedure as in the former sections one finds that the orthorhombic orientation space (OOS) is a cube. The explicit proof is easy and left to the reader. The length of the edges is 2, i.e.

$$|d_i| \leq 1, \quad i = 1, 2, 3.$$

The orthorhombic disorientation space is just that part of the OOS that is lying in the first octant of the Rodrigues vector space. Both spaces are plotted in Fig. 7.

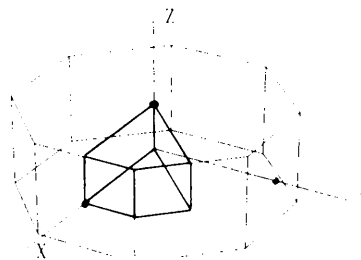

Fig. 6. Tetragonal orientation and disorientation space. The solid circles mark the intersection points of the axes with the surface of the disorientation space.

8. Disorientation between cubic and hexagonal crystals

In the case of disorientations between different crystal structures a new aspect arises for the representation by Rodrigues vectors.

If the point symmetry of one crystal structure is a subgroup of the other then the rotation axis is in the standard stereographic triangle of the lattice with lower symmetry (less elements of the group) and the maximum reduced rotation angle is that belonging to the group with higher symmetry. The proof was given in § 4. But if there is no subgroup relationship between the two crystal structures as in the case of cubic and hexagonal crystals then the standard stereographic triangle of both individual crystal classes is not adequate for the representation and a new standard stereographic triangle and a new compact domain must be defined. But, on the other hand, since there are elements of S^b not contained in S^a and *vice versa*, the maximum reduced rotation angle must be smaller than those of the two individual groups.

There are $12 \times 24 = 288$ symmetrically equivalent and proper rotations for the representation of disorientations between cubic and hexagonal crystals each transforming the frame connected with the hexagonal lattice onto that connected with the cubic one. Among these there are generally four different Rodrigues vectors covering the smallest rotation angle. Each of these vectors is lying in every other octant of the Rodrigues vector space. They can be transformed into each other by sole sign changes of their components. Thus the compact domain necessary for describing the cubic-hexagonal disorientations must cover parts of at least two octants. For simplicity we chose the first and second octants which can be described by the condition $d_2 \geq 0; d_3 \geq 0$. In other words, the standard stereographic triangle for cubic-hexagonal disorientations is the half circle between (001), (010) and (00 $\bar{1}$) of the stereographic standard projection. Thus the cubic-hexagonal disorientation space is restricted by only 72 out of the 288 inequalities and only one half of these is active in the first octant. From inspection of the related

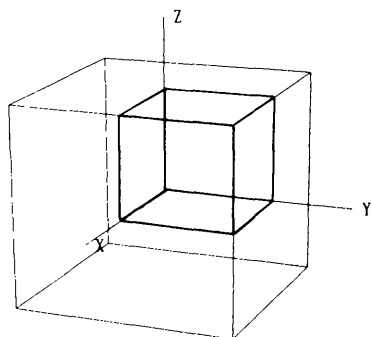

Fig. 7. Orthorhombic orientation and disorientation space.

quaternions one finds that only the following restrictions are relevant in the first octant:

$$\begin{aligned} (2^{1/2} - 1)q_0 &\geq q_i, \quad i = 1, 2 \\ q_0 &\geq 2^{1/2}[\frac{1}{4}(3^{1/2} + 1)q_0 + \frac{1}{4}(3^{1/2} - 1)q_3] \\ q_0 &\geq \frac{1}{4}(3^{1/2} + 1)(q_0 + q_2) + \frac{1}{4}(3^{1/2} - 1)(q_1 + q_3) \\ q_0 &\geq \frac{1}{4}(3^{1/2} + 1)(q_0 + q_1) + \frac{1}{4}(3^{1/2} - 1)(q_2 - q_3). \end{aligned}$$

For the Rodrigues vectors this yields

$$\begin{aligned} (2^{1/2} - 1) &\geq d_i, \quad i = 1, 2 \\ (2 \times 2^{1/2} - 3^{1/2} - 1)/(3^{1/2} - 1) &\geq d_3 \\ \beta &\geq \begin{pmatrix} \alpha \\ 1 \\ \alpha \end{pmatrix} \mathbf{d}, \quad \beta \geq \begin{pmatrix} 1 \\ \alpha \\ -\alpha \end{pmatrix} \mathbf{d} \end{aligned}$$

where

$$\alpha = (3^{1/2} - 1)/(3^{1/2} + 1), \quad \beta = (3 - 3^{1/2})/(3^{1/2} + 1).$$

The restrictions relevant to the second octant are treated analogously. These bound a domain that equals the one lying in the first octant and can be obtained by rotating it by 90° about (001). Together with the restrictions $d_i \geq 0; i = 2, 3$ for the standard stereographic triangle this yields the domain plotted as a stereopair in Fig. 8. For clearness a sliced representation of Fig. 8 is given in Fig. 9.

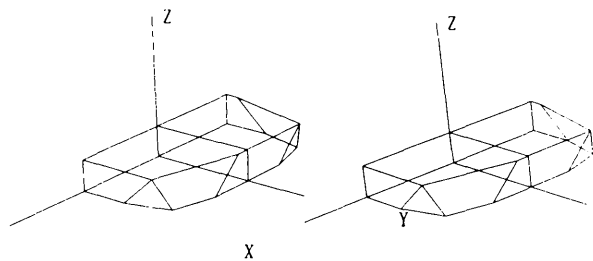

Fig. 8. Cubic-hexagonal disorientation space.

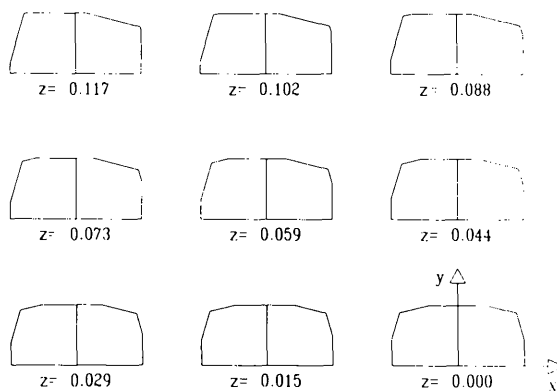

Fig. 9. Equidistant sections perpendicular to the d_3 axis through the cubic-hexagonal disorientation space of Fig. 8.

The corners of the base polygon of the cubic-hexagonal disorientation space in the first octant are

$$(x_0, 0, 0), \quad (x_0, x_1, 0), \quad (x_2, x_2, 0), \\ (x_1, x_0, 0), \quad (0, x_0, 0)$$

and the origin. The corners of the top polygon are

$$(x_0, 0, x_4), \quad (x_0, x_6, x_4), \quad (x_5, x_0, x_4), \\ (0, x_0, x_4), \quad (0, 0, x_4)$$

where

$$x_0 = (2^{1/2} - 1) \\ x_1 = (4 - 2^{1/2} - 6^{1/2}) / (3^{1/2} - 1) \\ x_2 = (3^{1/2} - 1) / 2 \\ x_3 = (3 - 3^{1/2}) / (3 \times 3^{1/2} - 1) \\ x_4 = (2 \times 2^{1/2} - 3^{1/2} - 1) / (3^{1/2} - 1) \\ x_5 = x_1 - x_4 \\ x_6 = (2^{1/2} - 3^{1/2} - 6^{1/2} + 3) / (3^{1/2} - 1).$$

The longest vector within the cubic-hexagonal disorientation space is (x_0, x_6, x_4) . The length of this vector yields a maximum rotation angle of $56 \cdot 60^\circ$.

9. Disorientations between cubic and tetragonal crystals

The disorientations between cubic and tetragonal crystals can be described by $24 \times 8 = 192$ different Rodrigues vectors. Among these there are generally eight having a minimal rotation angle. These can be divided into two groups. The first group fulfils the condition $|d_1| \geq |d_2|$ while for the second group the inequality $|d_1| \leq |d_2|$ is true. The four vectors of each group can be transformed into each other by definite sign changes of their components. For any arbitrary cubic-tetragonal disorientation (CTD) a reduced Rodrigues vector can be found in either the first or the second octant fulfilling the condition $|d_1| \geq |d_2|$.

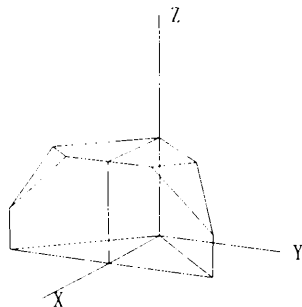

Fig. 10. Cubic-tetragonal disorientation space.

Thus for the representation of cubic-tetragonal disorientations Rodrigues vectors are lying in parts of two octants. For simplicity the first and second octants are chosen again. According to the above condition the standard stereographic triangle for cubic-tetragonal disorientations can be defined as the part of the standard projection lying between (001), (110) and (110).

The relevant restrictions derived from the demand for smallest rotation angle are

$$(2^{1/2} - 1) \geq d_i \geq 0, \quad i = 1, 3 \\ d_1 \geq |d_2|$$

and

$$1 \geq d_1 \pm d_2 + d_3.$$

Thus the cubic-tetragonal disorientation space is constructed as shown in Fig. 10. The cubic-tetragonal space is just one eighth of the cubic orientation space. It is that part of the cubic orientation space which is obtained by truncating it by planes having the normal vectors $(\bar{1}10)$, $(1\bar{1}0)$ and (001) . Thus only one half of the bounding triangles and of one octagonal side face remains. The octagonal top face is quartered. The longest vector within the cubic-tetragonal disorientation space is for example $(2^{1/2} - 1, 2^{1/2} - 1, 3 - 2 \times 2^{1/2})$ yielding a maximum rotation angle of $62 \cdot 80^\circ$. This does not agree with the results of Bonnet (1980), but again this seems to be due to a printer's error.

The general considerations at the beginning of § 8 are valid for any two lattices. Now they can be demonstrated explicitly by discussing the cubic-hexagonal and the cubic-tetragonal disorientations. If disorientations between such crystals are considered where the point group of the first is *not* a subgroup of the second then the maximum reduced rotation angle is reduced compared to the rotation angles of the two individual crystal structures. Further, a new standard stereographic triangle and a new disorientation space (compact domain) must be defined. Otherwise (if the first group is a subgroup of the second) the maximum reduced rotation angle of the group with the higher symmetry is valid and the standard stereographic triangle of the group with lower symmetry can be used. The disorientation space is just the m th part of the orientation space belonging to the group with higher symmetry. Since $6/mmm$ is not a subgroup of $m\bar{3}m$ the reduced rotation angle for cubic-hexagonal disorientations is $56 \cdot 60^\circ$ instead of $62 \cdot 80$ or $93 \cdot 84^\circ$ which are the values of the individual lattices. Further, a new standard stereographic triangle has to be defined. The maximum reduced rotation angle for the cubic-tetragonal disorientations is $62 \cdot 80^\circ$ as in the cubic case. The standard stereographic triangle is the cubic one and the CTD is an eighth of the cubic orientation space.

10. Disorientations of the remaining combinations of any two lattices

An analogous procedure for any remaining combination of two out of the specified lattices yields the compact domains plotted in Figs. 11-14.

1. Cubic-orthorhombic disorientation space

Since the orthorhombic group is a subgroup of the tetragonal group and the order of the orthorhombic group is 4 this domain is just a quarter of the cubic disorientation space (Fig. 11). The related standard stereographic triangle is the orthorhombic and the maximum reduced rotation angle is the cubic one.

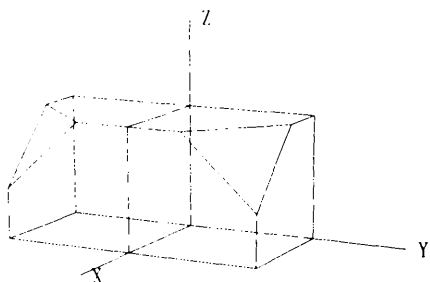

Fig. 11. Cubic-orthorhombic disorientation space.

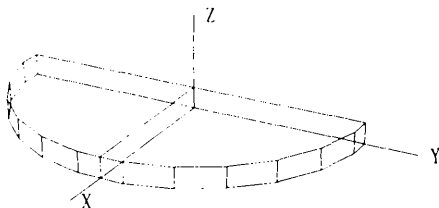

Fig. 12. Hexagonal-tetragonal disorientation space.

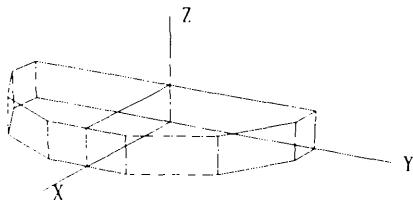

Fig. 13. Hexagonal-orthorhombic disorientation space.

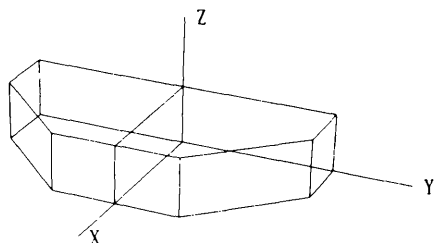

Fig. 14. Tetragonal-orthorhombic disorientation space.

It is noteworthy that the cubic-orthorhombic disorientation space is also used for describing orientations of cubic crystals in a rolled sheet. Due to the fabrication process the sheet has the orthorhombic symmetry of the rollers. Thus for a reduction this sample symmetry has to be used too. In this case, however, one is interested in orientations and not in disorientations. Orientations were defined as rotations that transform the crystal frame (CF) to the reference frame (RF). Thus here the direction of the rotations is not choosable as in the case of disorientations between non-identical lattices, where it is fixed by convention.

2. Hexagonal-tetragonal disorientation space

Since there is no subgroup relationship in this case a new domain had to be constructed. It is one half of a regular column (Fig. 12). The bottom face of the column has 24 corners, one of which is $(1, x_4, 0)$, where $x_4 = (2 \times 2^{1/2} - 3^{1/2} - 1) / (3^{1/2} - 1)$ as defined in § 8. $(1, 0, 0)$ is at the edge of the bottom. The height of the column is $|d|_3 \leq x_4$. All other corners can be found by symmetry. The maximum reduced rotation angle is $90 \cdot 98^\circ$ for $(1, x_4, x_4)$.

3. Hexagonal- and tetragonal-orthorhombic disorientation space

Since subgroups are involved the hexagonal-orthorhombic disorientation space (Fig. 13) and the tetragonal-orthorhombic disorientation space (Fig. 14) are just parts of the hexagonal orientation space, or the tetragonal orientation space respectively.

The results of our paper are summarized in Table 1.

11. Concluding remarks

A unified method for representing the orientation and disorientation data of cubic, hexagonal, tetragonal and orthorhombic crystals is given for the first time. The method has definite advantages compared with those dealing with Eulerian angles, pole figures or inverse pole figures, especially in cases where the individual orientations and disorientations of large numbers of crystals are considered. The method can be applied to any type of crystal structure or pair of crystal structures respectively. The orientations and disorientations lie in compact domains always bounded by planes.

We thank the Deutsche Forschungsgemeinschaft for financial support under contract no. Ne 193/17-1.

The helpful cooperation of Mrs M. Feldges in writing and testing the programs is gratefully acknowledged.

Table 1. Maximum reduced rotation angles, longest Rodrigues vectors, restrictions for Rodrigues vectors and range of rotation axes for any combination of two symmetries

Lattice symmetries	Maximum reduced rotation angle	Longest Rodrigues vector	Restrictions/range of rotation axes
Cubic	62.80	$(2^{1/2}-1, 2^{1/2}-1, 3-2 \times 2^{1/2})$	None / R^3
Hexagonal	93.84	$[(3^{1/2}-1), (3^{1/2}-1), (2-3^{1/2})]$	None / R^3
Tetragonal	98.42	$[1, (2^{1/2}-1), (2^{1/2}-1)]$	None / R^3
Orthorhombic	120	(1, 1, 1)	None / R^3
Cubic-cubic	62.80	$(2^{1/2}-1, 2^{1/2}-1, 3-2 \times 2^{1/2})$	$d_1 \geq d_2 \geq d_3 \geq 0$ / cubic SST*
Hexagonal-hexagonal	93.84	$[(3^{1/2}-1), (3^{1/2}-1), (2-3^{1/2})]$	$d_3 \geq 0, (1/3^{1/2})d_1 \geq d_2 \geq 0$ / hexagonal SST*
Tetragonal-tetragonal	98.42	$[1, (2^{1/2}-1), (2^{1/2}-1)]$	$d_3 \geq 0, d_1 \geq d_2 \geq 0$ / tetragonal SST*
Orthorhombic-orthorhombic	120	(1, 1, 1)	$d_i \geq 0, i = 1, 2, 3$ / orthorhombic SST*
Cubic-hexagonal	56.60	(x_0, x_6, x_4)	see § 8 / 1+2 octant of R^3 = double orthorhombic SST*
Cubic-tetragonal	62.80	$(2^{1/2}-1, 2^{1/2}-1, 3-2 \times 2^{1/2})$	1/8 of cubic / doubled tetragonal SST*
Cubic-orthorhombic	62.80	$(2^{1/2}-1, 2^{1/2}-1, 3-2 \times 2^{1/2})$	1/4 of cubic-cubic / doubled orthorhombic SST*
Hexagonal-tetragonal	90.98	(1, x_4, x_4)	see § 10 / doubled orthorhombic SST*
Hexagonal-orthorhombic	93.84	$[(3^{1/2}-1), (3^{1/2}-1), (2-3^{1/2})]$	1/4 of hexagonal-hexagonal / doubled orthorhombic SST*
Tetragonal-orthorhombic	98.42	$[1, (2^{1/2}-1), (2^{1/2}-1)]$	1/4 of tetragonal-tetragonal / doubled orthorhombic SST*

$x_0 = (2^{1/2}-1)$, $x_4 = (2 \times 2^{1/2} - 3^{1/2} - 1)/(3^{1/2}-1)$ and $x_6 = (2^{1/2} - 3^{1/2} - 6^{1/2} + 3)/(3^{1/2}-1)$.

* SST = standard stereographic triangle.

References

- BECKER, S. & PANCHANADEESWARAN (1989). *Text. Microstruct.* **10**, 167.
- BIRSS, R. R. (1964). In *Symmetry and Magnetism*, edited by E. P. WOHLFARTH. London: North Holland.
- BONNET, R. (1980). *Acta Cryst.* **A36**, 116-122.
- BUNGE, H. J. (1982a). In *Quantitative Texture Analysis*, edited by C. ESLING & H. J. BUNGE. Oberursel: DGM.
- BUNGE, H. J. (1982b). *Texture Analysis in Material Science*. London: Butterworth.
- BUNGE, H. J. (1987). *Theoretical Methods of Texture Analysis*. Oberursel: DGM.
- BUNGE, H. J. (1988). Proc. Int. Conf. on Texture of Materials 8 (ICOTOM-8), Santa Fé, USA, p. 69.
- DUVAL, P. (1964). *Homographies, Quaternions and Rotations*. Oxford Univ. Press.
- FRANK, F. C. (1987). Proc. Int. Conf. on Texture of Materials 8 (INCOTOM 8), Santa Fé, USA, pp. 3-13.
- GERTSMAN, V. Y. (1989). Proc. Int. Conf. on Intergranular and Interface Boundaries, Paris, France, pp. C1-145-C1-150.
- GRIMMER, H. (1974). *Acta Cryst.* **A30**, 685-688.
- HAESSNER, F. & SCHRÖDER, G. (1977). *Z. Metallkd.* **68**, 624-635.
- HANDSCOMB, D. C. (1958). *Can. J. Math.* **10**, 85-88.
- HANSEN, J., POSPIECH, J. & LÜCKE, K. (1978). *Tables for Texture Analysis of Cubic Crystals*. Berlin: Springer.
- HELMIG, K., MATTHIES, S. & VINEL, G. W. (1988). Proc. Int. Conf. on Texture of Materials 8 (ICOTOM-8), Santa Fé, USA, p. 55.
- MACKENZIE, J. K. (1958). *Biometrika*, **45**, 229-240.
- MATTHIES, S., HELMIG, K. & KUNZE, K. (1990). *Phys. Status Solidi B*, **157**, 71, 489.
- MORRIS, R. & HECKLER, A. J. (1969). *Trans. Met. Soc. AIME*, **245**, 1877-1881.
- NEUMANN, P. (1990). Proc. Int. Conf. on Texture of Materials 9 (INCOTOM 9), Avignon, France.
- RODRIGUES, O. (1840). *J. Math. Pure Appl.* **5**, 380-440.
- WAERDEN, B. L. VAN DER (1932). *Die Gruppentheoretische Methode in der Quantenmechanik*. Berlin: Springer.

Acta Cryst. (1991). **A47**, 789-794

Dynamical RHEED Calculations of Relaxation on Au(110)- 2×1 Reconstruction

BY J. E. BONEVICH, Y. MA* AND L. D. MARKS

Department of Materials Science and Engineering, Northwestern University, Evanston, IL 60208, USA

(Received 23 March 1991; accepted 12 June 1991)

Abstract

Dynamical calculations of reflection high-energy electron diffraction (RHEED) from the 2×1 missing

row reconstruction of the Au(110) surface have been simulated as a function of surface-atom relaxation at different incident glancing angles using the multislice approach with the edge-patching method. The results demonstrate that the diffracted-beam intensity is extremely sensitive to the surface structure; small surface relaxations lead to large amplitude changes,

* To whom all correspondence should be addressed at: Department of Physics, University of Oslo, PO Box 1048, Blindern, 0316 Oslo 3, Norway.